

Market Landing Park Expansion

Ad Hoc Committee Meeting
October 25th, 2022

City of Newburyport, Massachusetts
Mayor Sean R. Reardon
Newburyport City Council
Department of Planning and Development

SASAKI

Agenda

PRESENTATION

- Sasaki update on plans for Park Expansion & new Visitor Center/Restroom facility
- Review of Phase I Scope of Work & Budget (2023 Construction)
- Review of Funding Gap for Site Amenities / Additional grants/funding needed

Goals

- Provide updates on park and architecture design refinements during permitting
- Present phasing, interim conditions, and budget to understand the City's priorities and expectations for 100% CD documentation

Market Landing Park Design Process: Next Steps

SITE INVENTORY

(TASKS 1,2 & 3)

APRIL-MAY 2021

- Inventory existing documents
- Conduct site survey
- Gather stakeholder input

CONCEPT + SCHEMATIC DESIGN

(TASKS 4,5 & 6)

JUNE - SEPT 2021

Concept Alternatives

- 1
- 2
- 3

Refined Conceptual Plan



Visitors Center:
Concept Development

Concept Alternatives Refined Concept

CURRENT WORK: FALL 2022 COMPLETION

ARCHITECTURE SCHEMATIC DESIGN
(TASKS 7)

2022

ARCHITECTURE + LANDSCAPE DESIGN DOCUMENTATION
(TASKS 7)

2022

Design Development



Construction Documentation



FUTURE WORK

BIDDING
(TASKS 8)

WINTER 2023

CONSTRUCTION
(TASKS 9)

SPRING 2023 THROUGH 2024

Ad-Hoc Committee Meetings (Public):

4 meetings were held during Task 1-6



75% Review

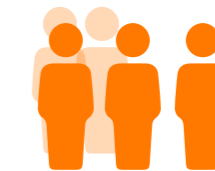

100% Review

We are here!

Proposed Plan



Somersby
Sculpture
Plaza

Drop Off
Area

Seating
Area

Embayment

West
Embayment
Plaza

Shared Use Path

Harbormaster
Entry Drive

Harbormaster

Somersby Way

West
Lot

Central Wharf Way

Stage
Newburyport
Waterfront Trust
Property
Existing to remain

Ferry Wharf Plaza

East Lot

Custom House Way

Visitors Center +
Restrooms

Upper Railroad Way

Lower Railroad Way

Ferry Wharf Way

Deliveries+
Dumpster
Enclosure

Fire
House

Custom
House

0 25 50 100 ft



Summary of Planning Board Feedback

Bicycle Circulation + Parking

- Add bicycle parking at either ends of shared use path
- Add bicycle parking location signs throughout the park
- Consider alternate bicycle racks
- Widen bike path at boardwalk to provide space for bike dismounting, and redirect pedestrians at western edge of shared used path by adjusting the curb and grading
- Revise terminus of the shared use path to guide users towards the parking lot

Vehicular Circulation + Parking

- 2 EV spots included in the west lot (level 2), the eastern most bay will be electrical service ready
- Provide figure that illustrates interim parking spaces
- Reconsider west parking lot circulation at the intersection of WFT lot and City proposed lot
- Add pathways to reduce conflicts between pedestrians and service vehicles between Ferry Wharf Way and the East Lot

Swing Trellis

- Provide design parameters for Planning Board to approve

Visitors Center Screening

- After review of more detailed plans for both screening options, the Board approved Option 2 - Buffer Planting + Trellis

Vehicular + Bicycle Circulation

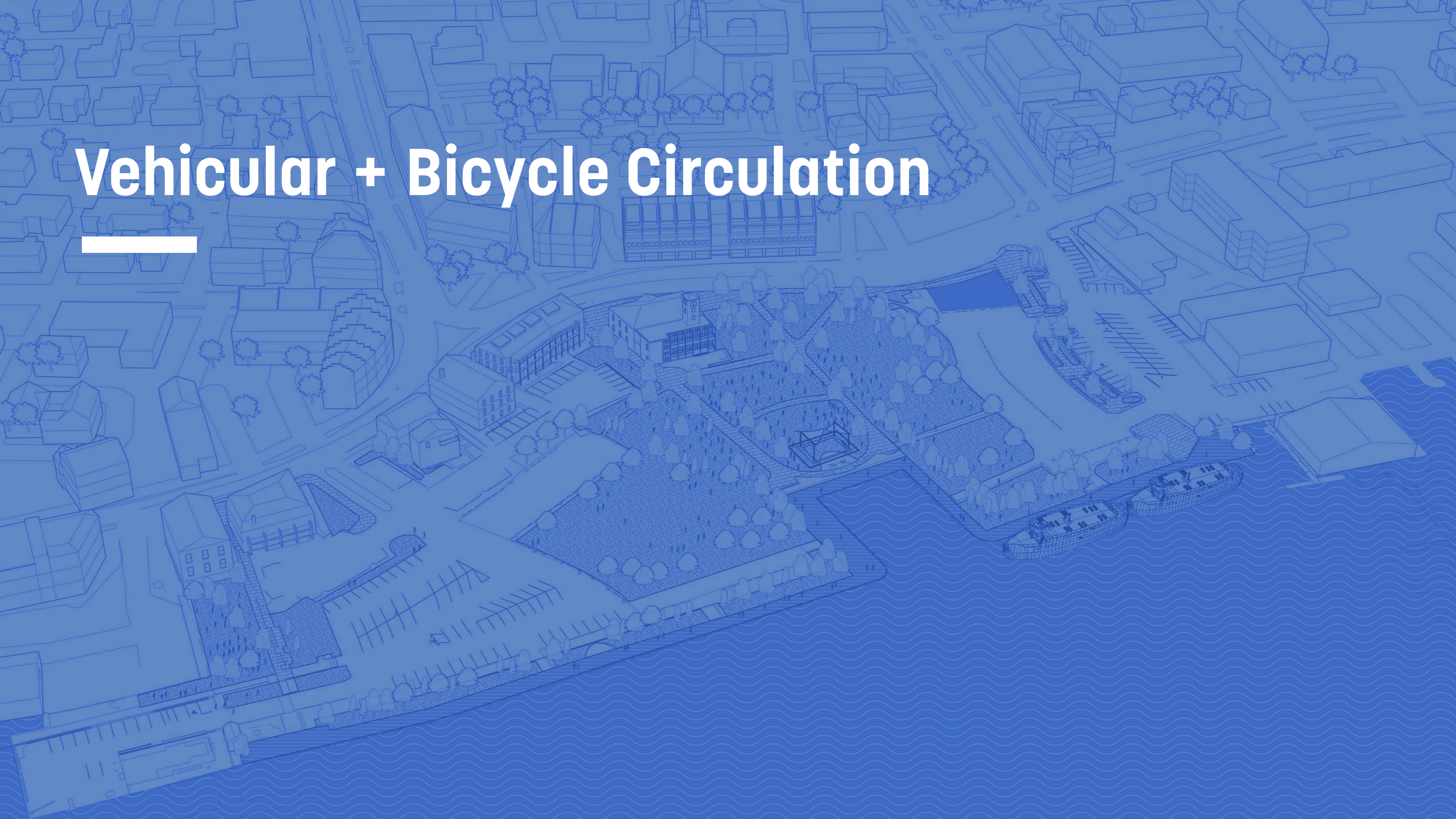

Bicycle Circulation + Parking



Existing Bicycle Racks

**BICYCLE PARKING
LOCATION SIGN**

6

**WIDENED SHOULDER
FOR BIKE PULL OFF**

**BICYCLE PARKING
LOCATION SIGN
ADDITIONAL
BICYCLE RACKS**





3

**BICYCLE PARKING
LOCATION SIGN**

5

**ADDITIONAL
BICYCLE RACKS**

5

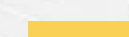
-  Bicycle Racks: 28 proposed, 3 existing to remain
-  Shared-Use Path
-  Primary Park Pathways
-  Secondary Park Pathways
-  Activation Nodes



Vehicular Circulation + Parking

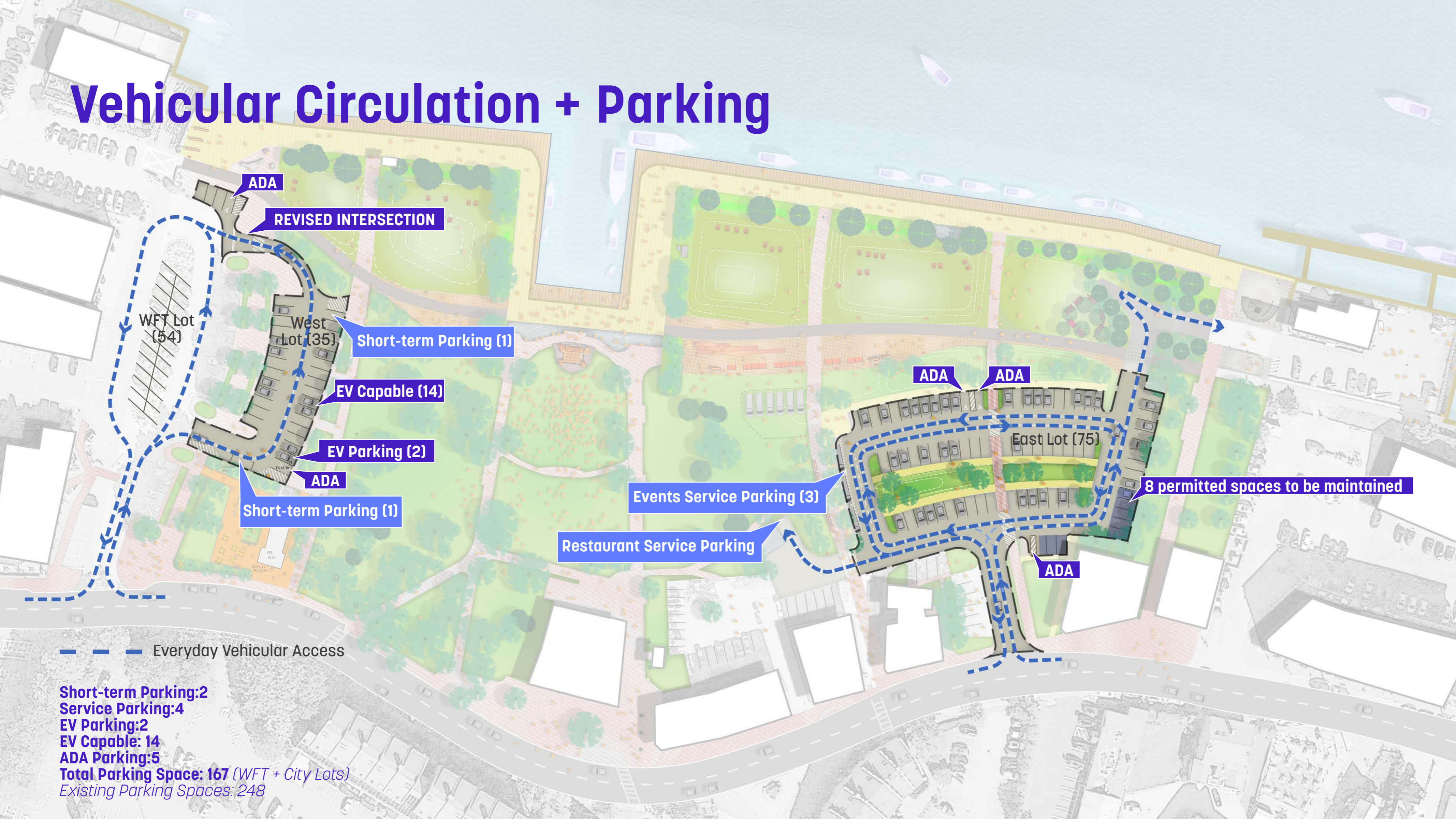

— — — Everyday Vehicular Access

Short-term Parking: 2
Service Parking: 4
EV Parking: 2
EV Capable: 14
ADA Parking: 5
Total Parking Space: 167 (WFT + City Lots)
Existing Parking Spaces: 248

West Lot

EV Parking + Shared Use Path Terminus

Asphalt path has been widened to 21' to direct pedestrians and cyclist towards the parking lot.

Existing boulders will be relocated here and spaced at 6' to prevent vehicular traffic but allow for pedestrians circulation.

2 charging stations will be installed in Phase 2 with parking lot construction

Transformer

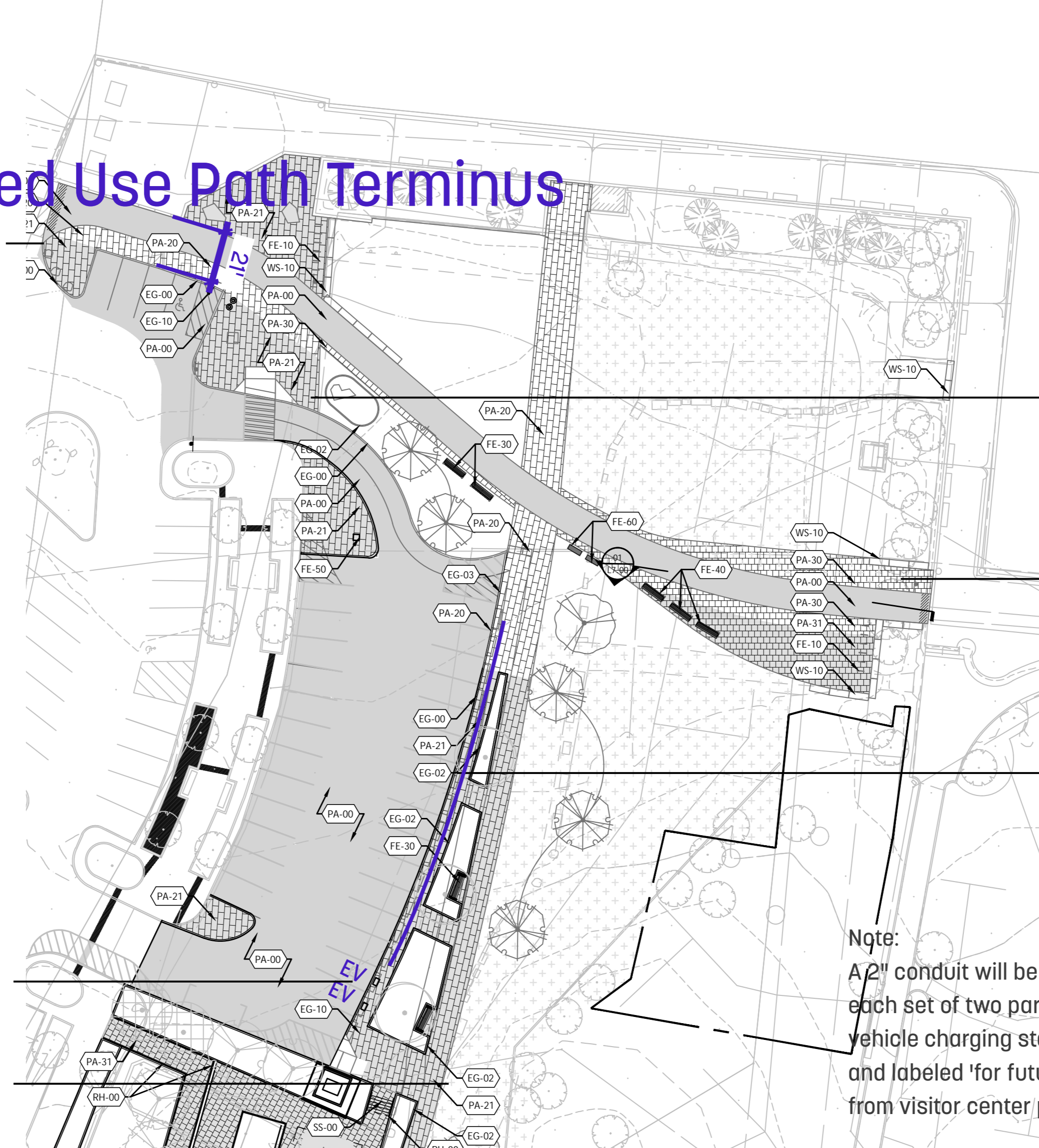

To clarify vehicular circulation curb line has been adjusted, stop sign, One way /Do not Enter signage and pavement striping have been added.

Widened shoulder to 10' and add signage to allow for cyclist to dismount before approaching the boardwalk and reduce congestion.

This row of parking will be documented as EV capable for 100% CD set (14 parking spots).

Note:

A 2" conduit will be provided from visitor center panelboard to each set of two parking spaces for future double port electric vehicle charging stations. Conduit will be stubbed, capped, and labeled 'for future electric vehicle charging station, fed from visitor center panelboard'.

East Lot Bicycle Parking + Circulation

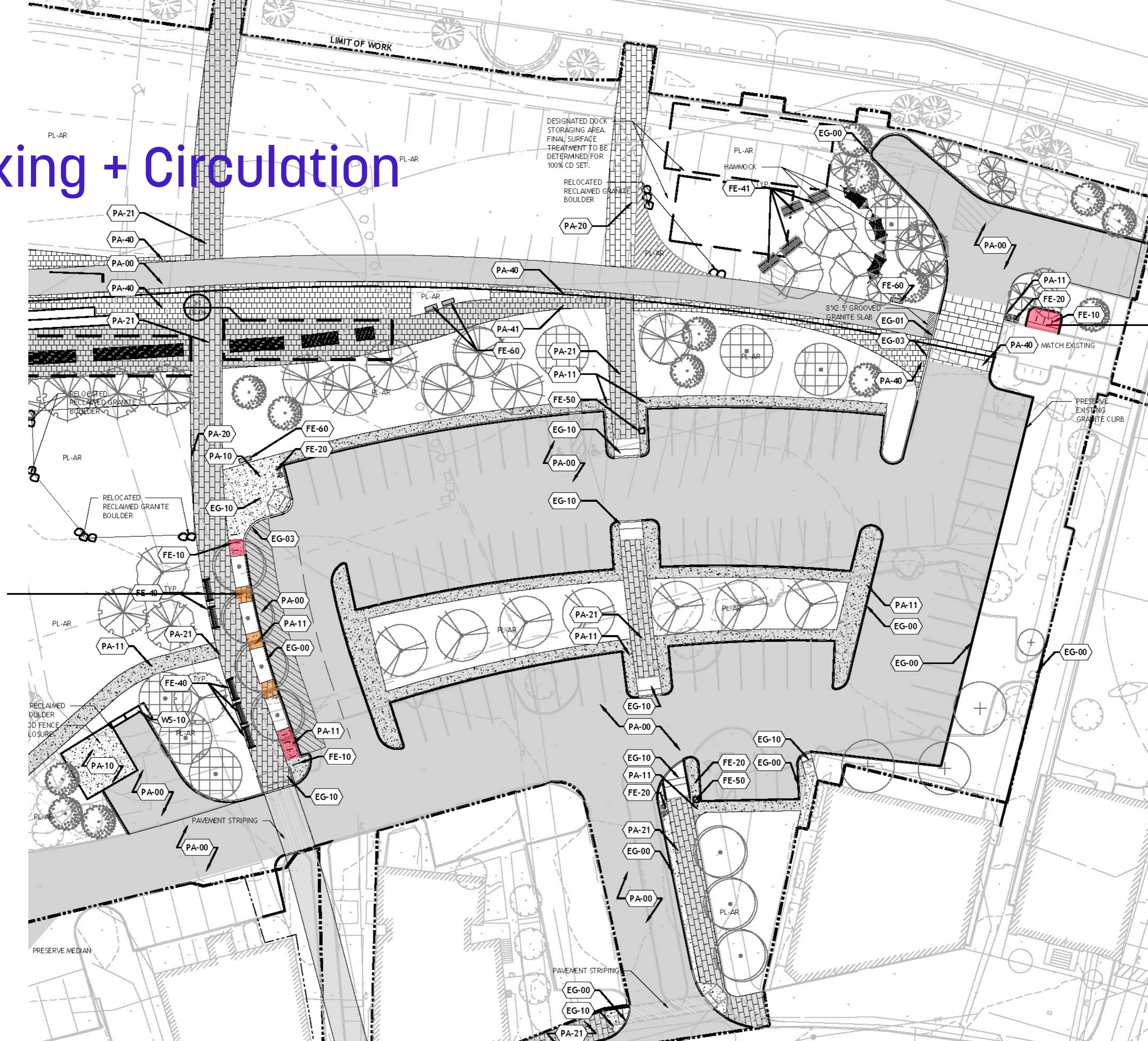

Additional bicycle racks + bicycle parking location sign have been added

Pathways have been added to provide more direct access to sidewalks from service vehicles and avoid conflicts with bicycle parking

Swing Trellis



Swing Trellis

Design Parameters

Materials

Wood Slats + Metal Frame



Metal



Wood

Function

Shade + Range of Swing Types

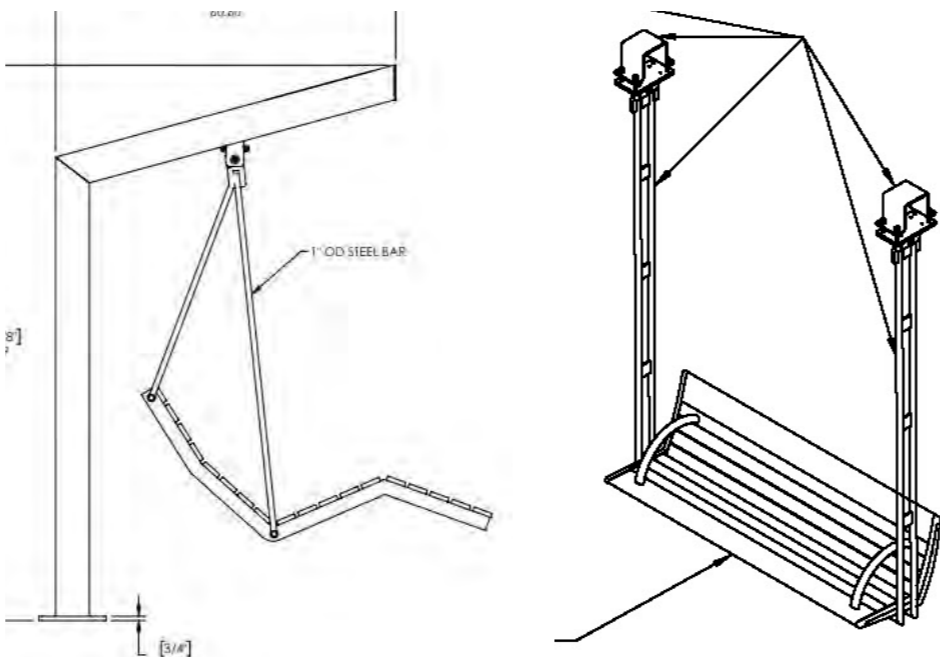

Scale

Presence on the Plaza



Swing Trellis

75% Design



An aerial architectural rendering of a city block, showing various buildings, streets, and a central plaza area. The rendering is in a light blue color scheme. The text is overlaid on the top left portion of the image.

Visitors Center, Restroom Facility + Plaza

- Restroom Screening + Landscape Design Refinements
- Resiliency: Building FFE + Adaptability

Proposed Site Plan



Somersby Way

West Lot (35)

Central Wharf Way

Visitors Center + Restrooms

Upper Railroad Way

Fire House

Lower Railroad Way

Ferry Wharf Way

Shared Use Path

Custom House

Custom House Way

Harbormaster

0 25 50 100 ft



Visitor Center + Restroom Facility



Visitor Center Plan

4 Single Stall Restrooms

4 ADA / Family Restrooms

Mechanical Room

Visitor Center

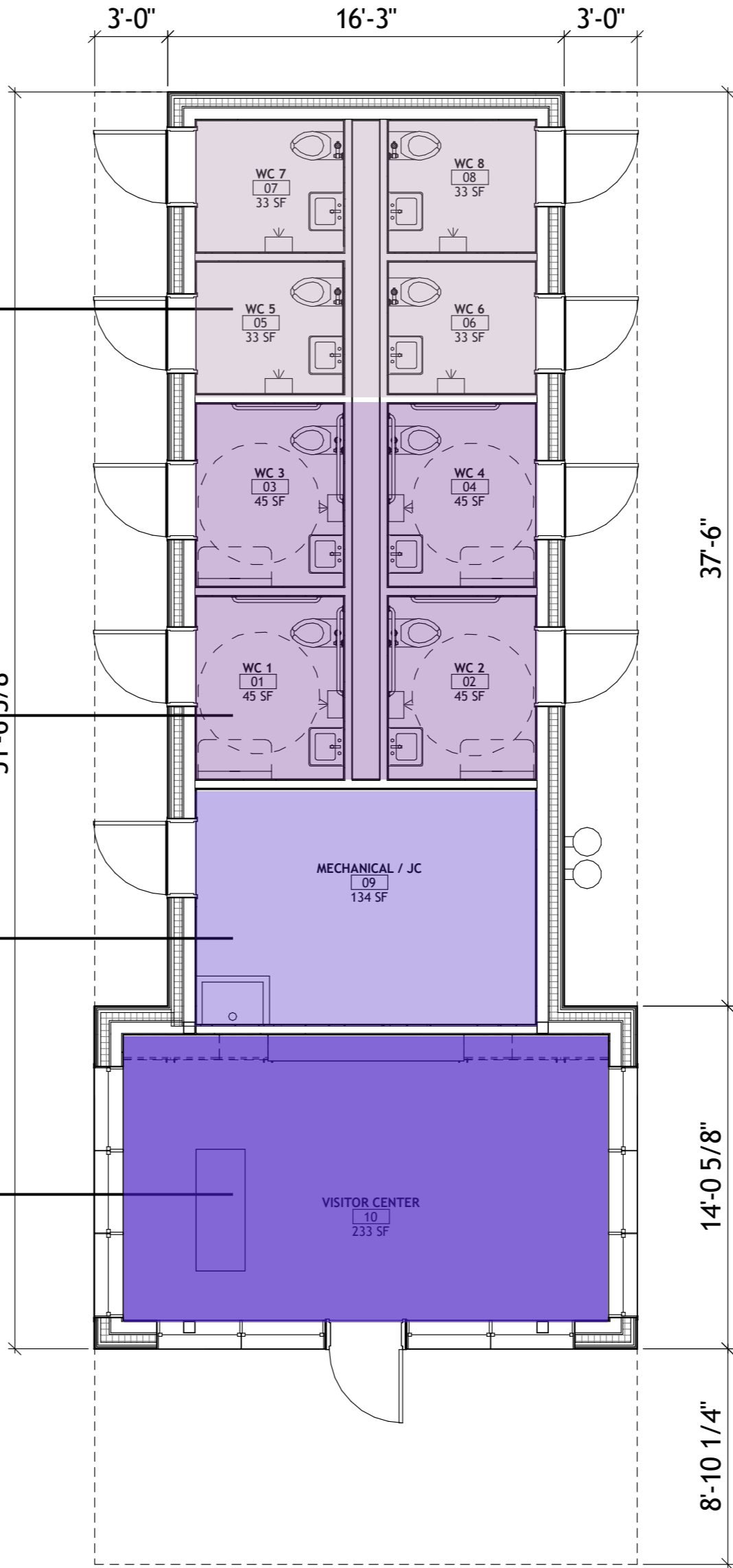

Visitor Center and Restroom Facility

Net Zero Building

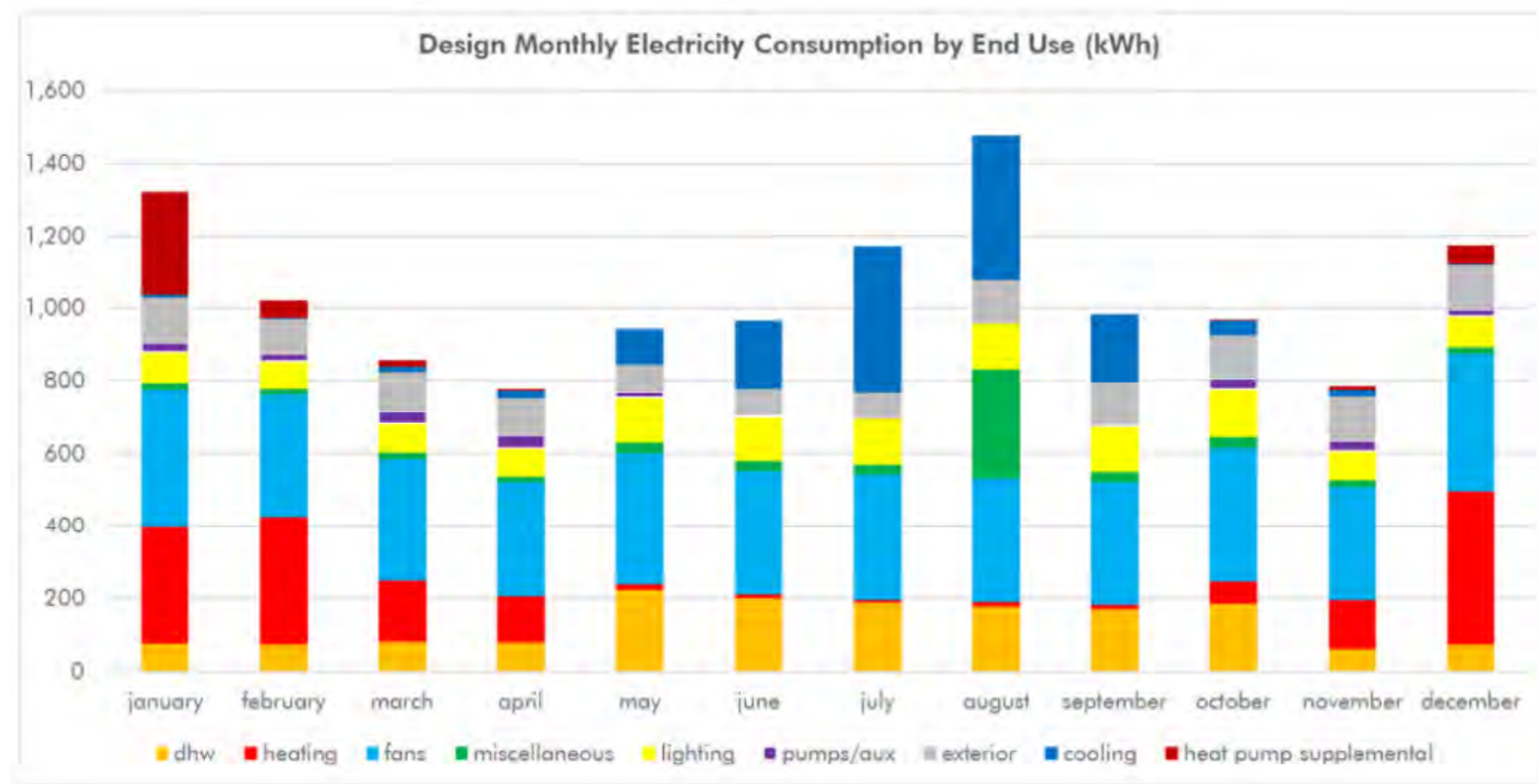

Considerations:

- The building is designed to be Net Zero Energy where photovoltaic panels produce enough energy to power the HVAC systems, lighting, and hot water.
- Based on the estimated annual energy consumption of approximately 12,500 kWh, a 10kW rated, roof mounted photovoltaic array should be capable of producing enough electricity on an annual basis to offset consumption.
- For more information, refer to memo submitted by RFS Engineering in October 2022.

Visitor Center Plaza and Restroom Screening Components

Trellis Design

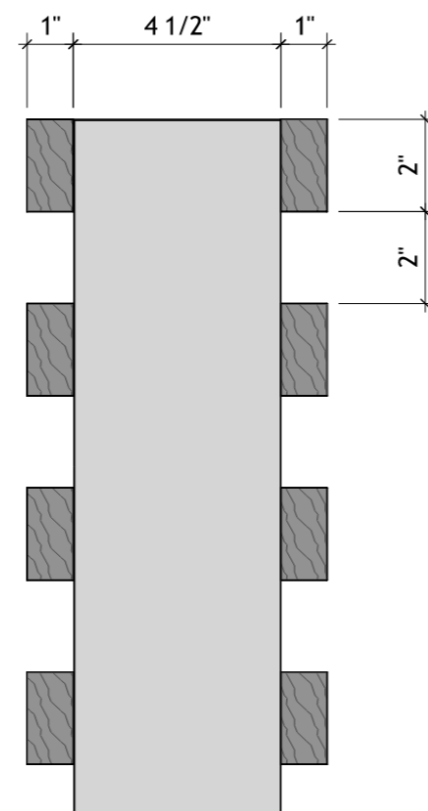
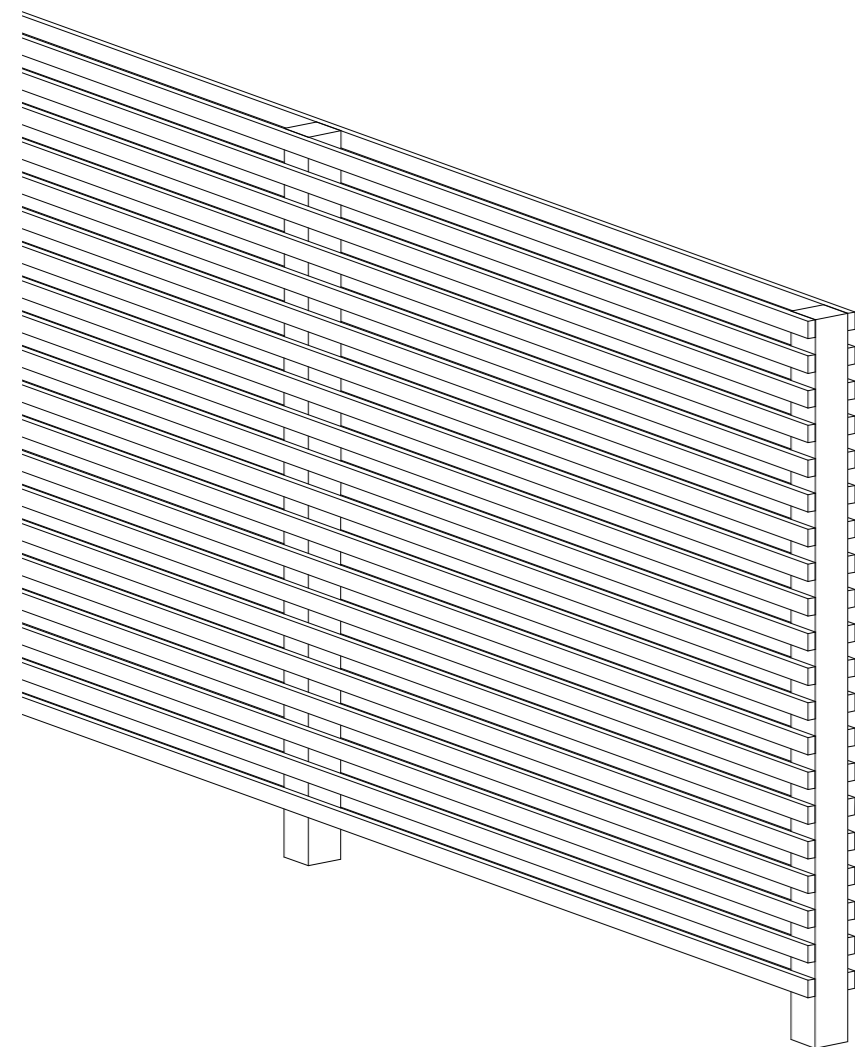
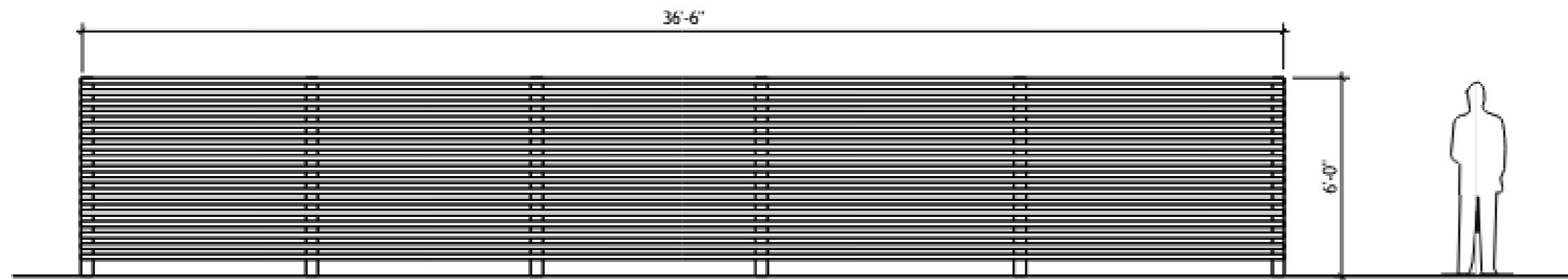

Evergreen Trees and Shrubs

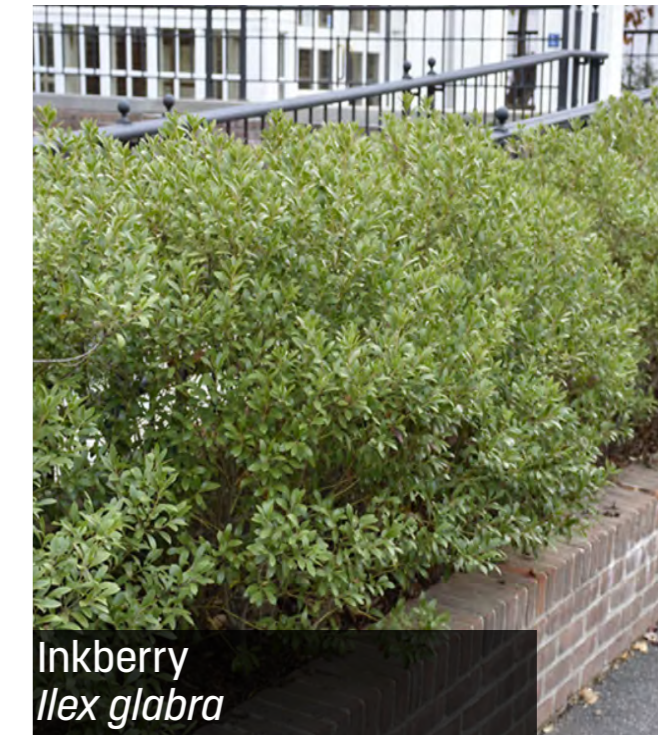

Visitor Center Plaza and Restroom Screening

Planted Buffer + Trellis

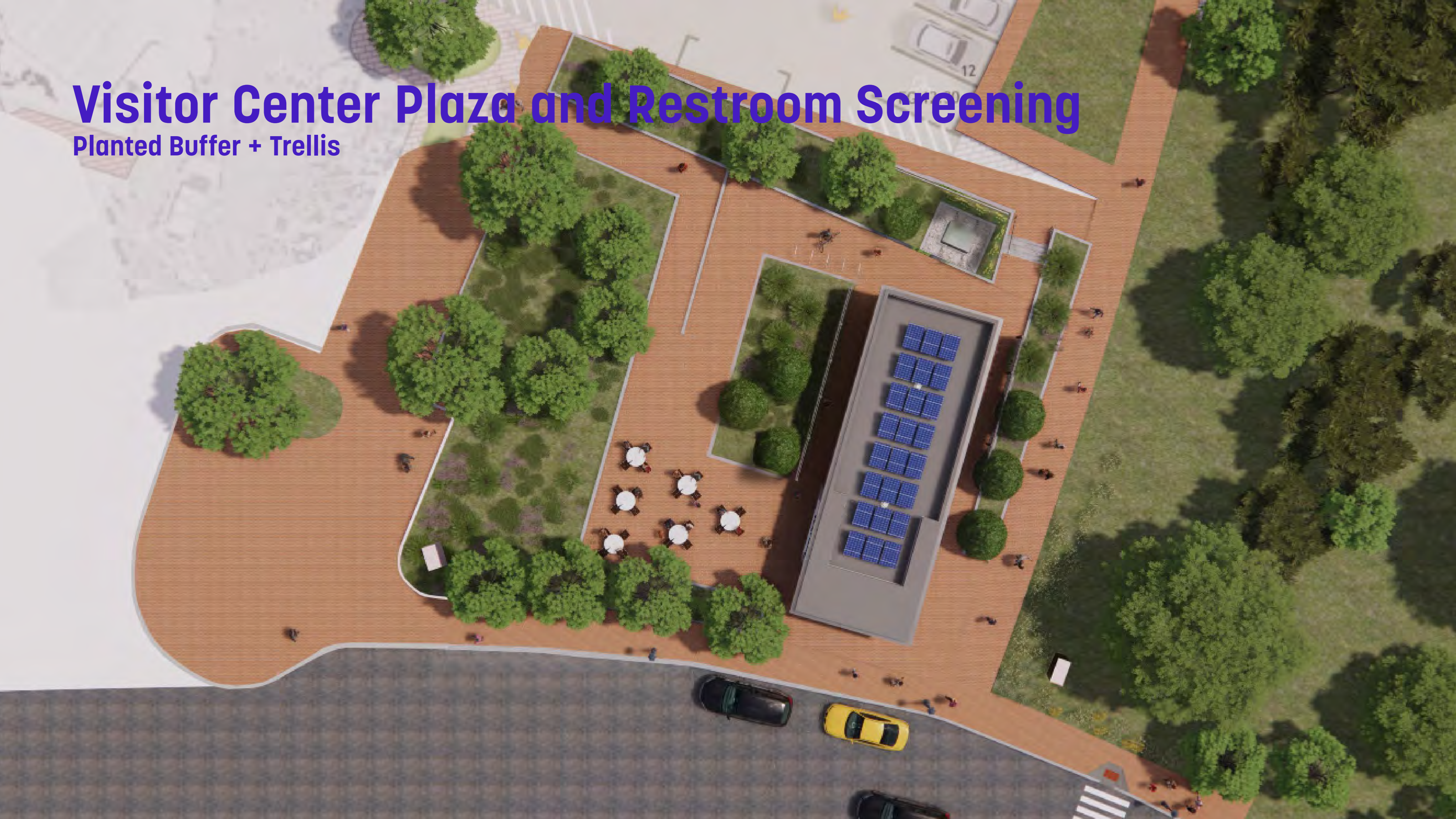

Visitor Center Plaza and Restroom Screening Components

Planted Buffer + Trellis

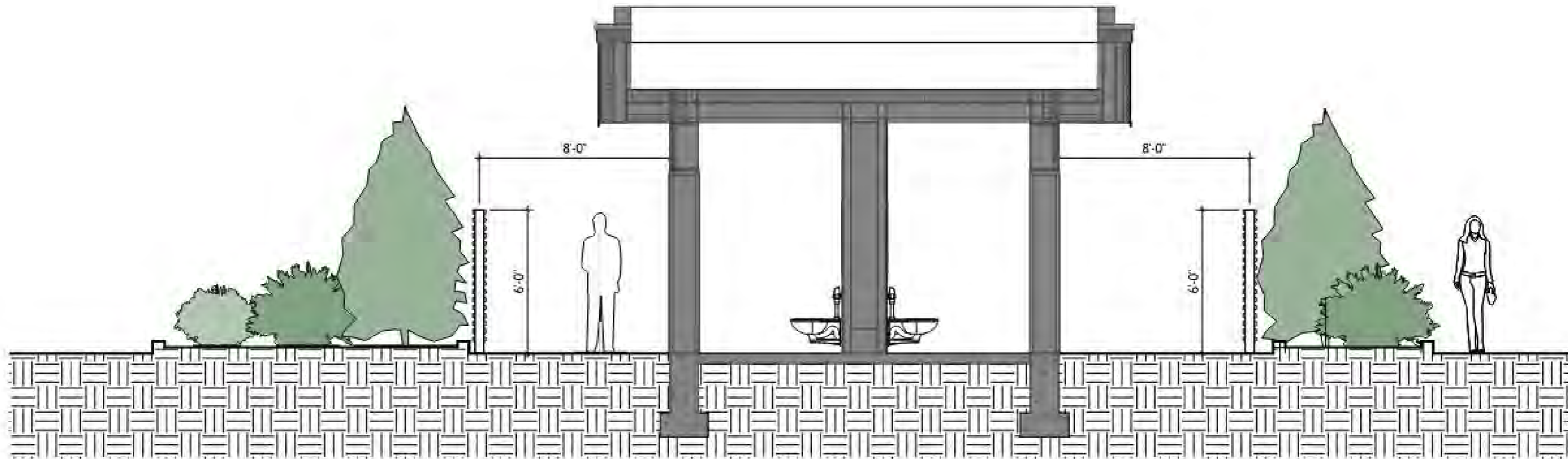

Visitor Center Plaza and Restroom Screening

Planted Buffer + Trellis



Visitor Center Plaza and Restroom Screening

Planted Buffer + Trellis



Resiliency

Building FFE

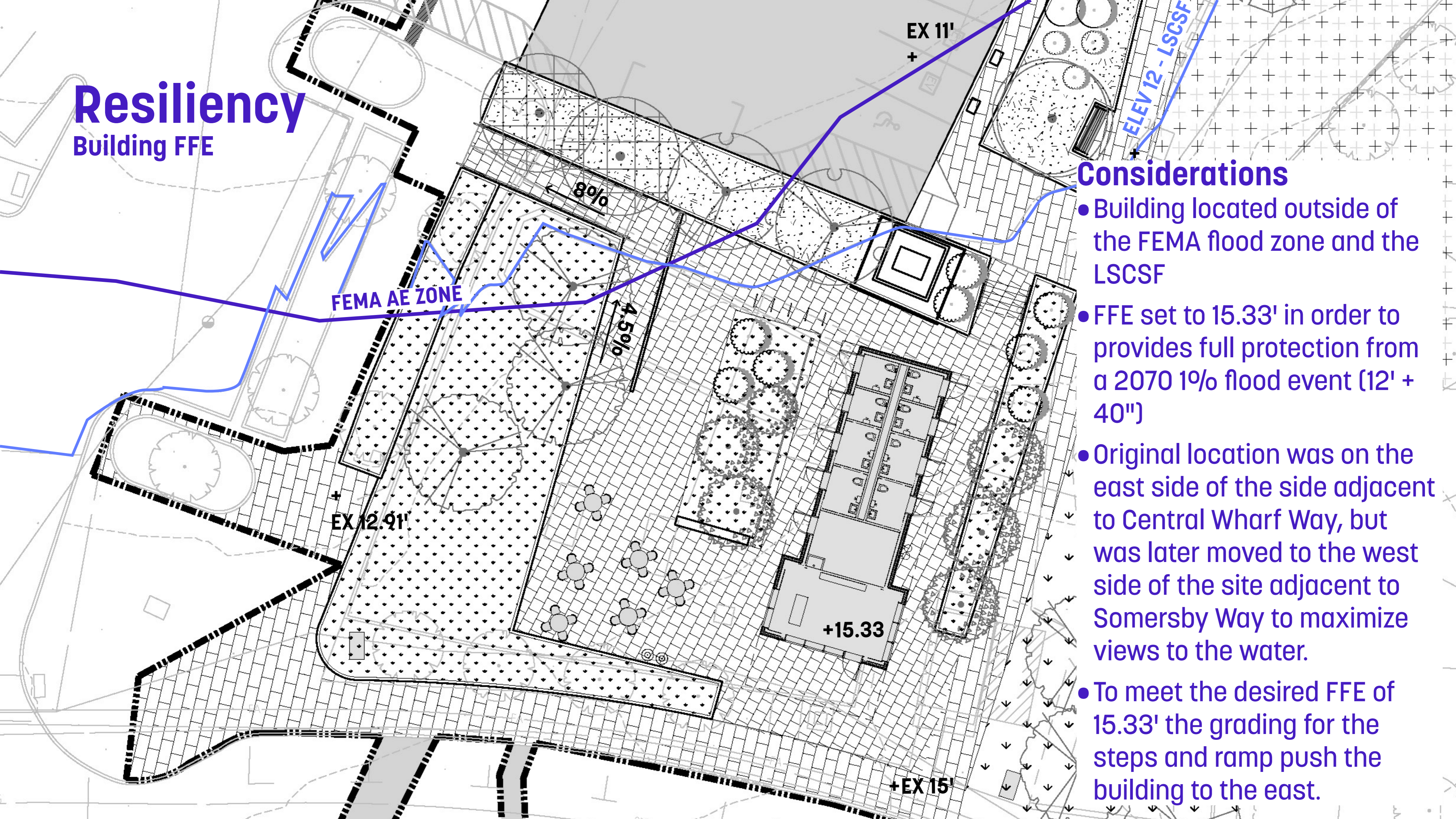

Considerations

- Building located outside of the FEMA flood zone and the LSCSF
- FFE set to 15.33' in order to provides full protection from a 2070 1% flood event (12' + 40")
- Original location was on the east side of the site adjacent to Central Wharf Way, but was later moved to the west side of the site adjacent to Somersby Way to maximize views to the water.
- To meet the desired FFE of 15.33' the grading for the steps and ramp push the building to the east.

Resiliency

Adapting for the Future

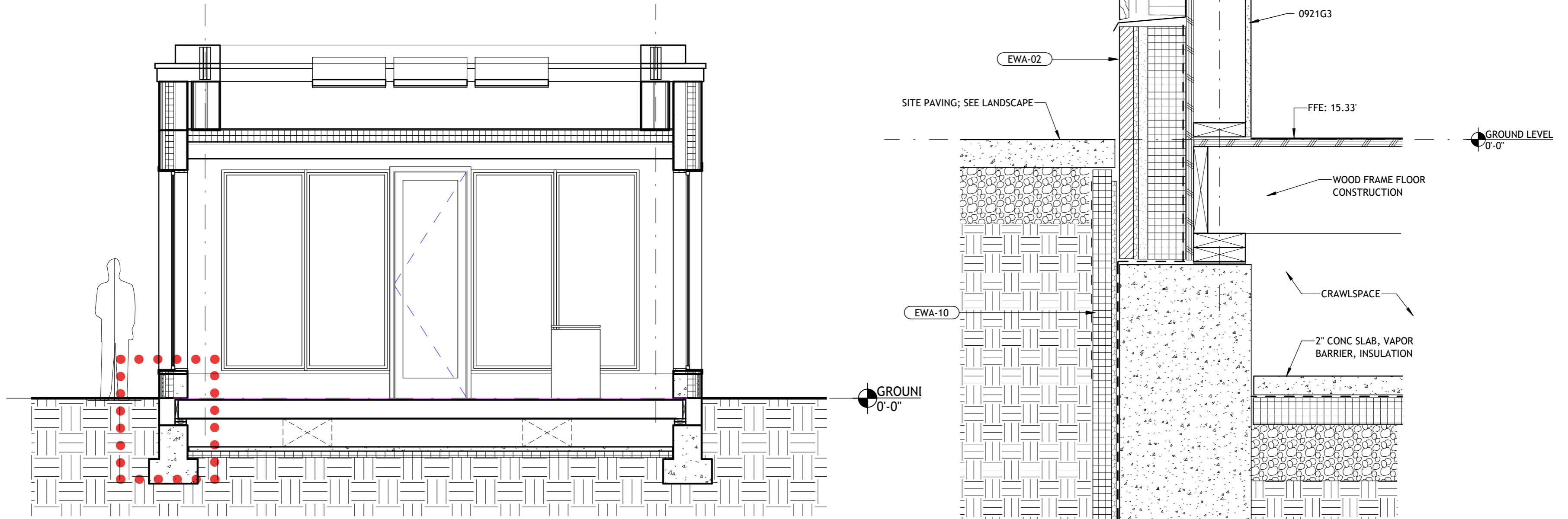

Considerations:

- The building is designed to be raised in the future. Instead of traditional slab-on-grade construction, the building is to be designed with a wood floor diaphragm that is attached to the walls and elevated above a crawl space. The foundation wall will be designed with "knock outs" for future access for raising. Utility pipes below the floor will be able to be reset to a higher elevation building.
- In keeping with the net-zero design, continuous insulation would be below the crawl space creating a "conditioned" space below the building.



Phasing + Budget

Understanding Project Costs and Implementation

Phasing Plan

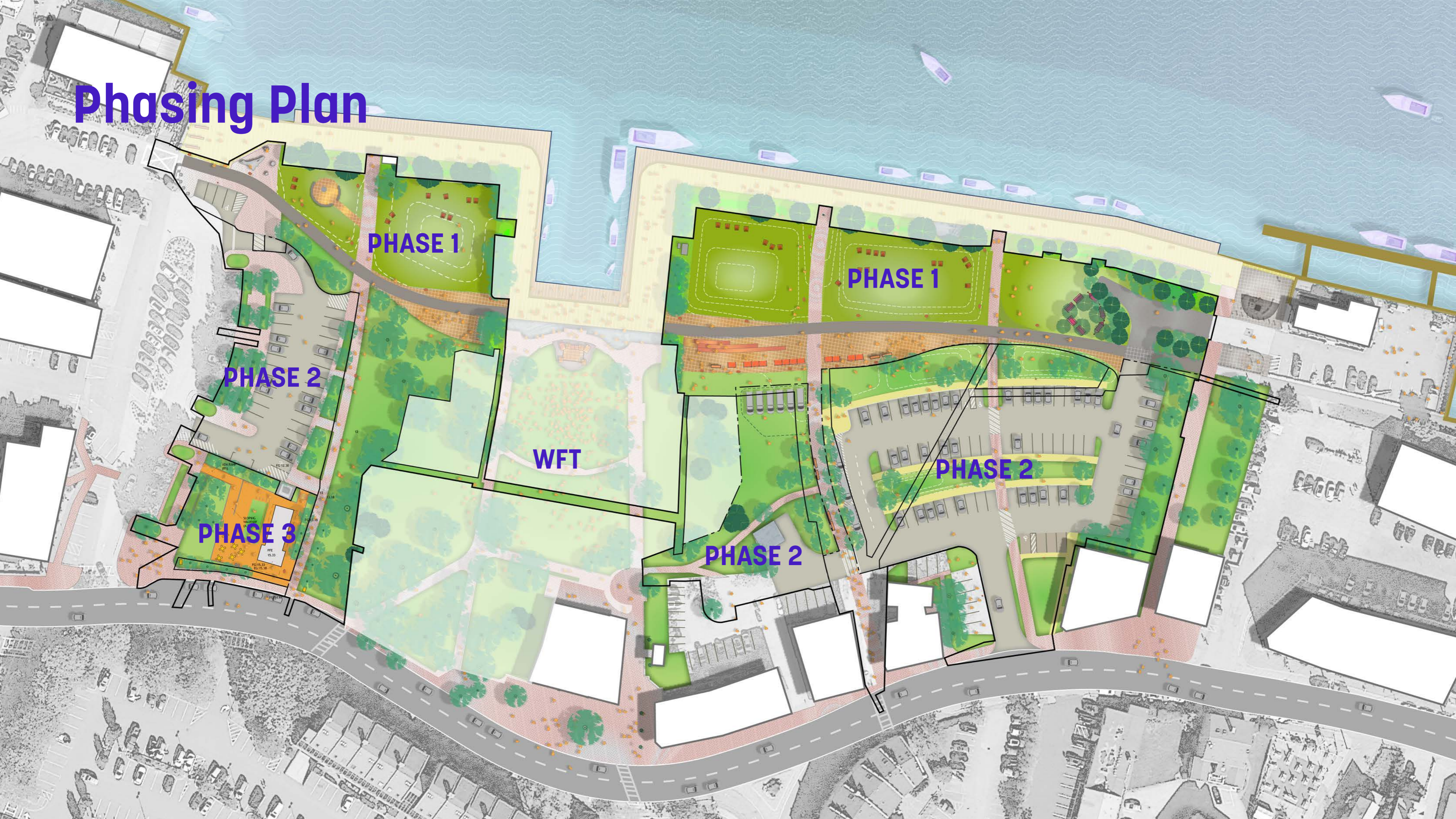

PHASE 1

PHASE 1

PHASE 2

WFT

PHASE 2

PHASE 3

PHASE 2

Phase 1 with Interim Parking Layout

Interim conditions until Phase 2 parking areas are complete



	NRA East	NRA West	WFT	Total
2021 Parking Count (after 2019 interim lawn installation)	126 (4 HP Spaces)	65 (3 HP Spaces)	54 (3 HP Spaces)	245
Parking Count Phase 1 (after Market Landing Park Expansion Phase 1)	80 (1 HP Spaces)	33 (1 HP Spaces)	54 (3 HP Spaces)	167
Total Proposed Parking Count	75 (3 ADA)	35 (2 ADA, 2 EV)	54 (3 HP Spaces)	164

Cost Estimate Summary for Phases 1

Item No.	Construction Cost	Phase 1: Path+ Plazas
CONSTRUCTION COSTS		
A	Site Preparation & Demo	\$ 492,206
B	Earthwork	\$ 396,300
C	Utilities & Infrastructure	\$ 785,330
D	Hardscape and Surface Finishings	\$ 731,266
E	Site Walls	\$ 301,882
F	Site Furnishings	\$ 407,471
G	Site Stairs and Handrails	\$ 5,855
H	Landscaping	\$ 153,085
I	Lighting	\$ 203,728
J	Special Elements	\$ 47,840
BASE BID TOTAL		\$ 3,524,963
Phase 1 2021 Budget		\$ 3,000,000
Revised June 2022 Phase 1 Budget		\$ 3,599,460

ADDITIONAL COSTS		
1	General Conditions/Gen Req's (8%)	\$ 281,997
2	Insurance + Bond (2%)	\$ 70,499
3	Design + Pricing Contingency (5%)	\$ 176,248
4	Construction Contingency (7.5%)	\$ 264,372
5	Escalation Contingency (4%)	\$ 140,999
6	Construction Administration (2%)	\$ 70,499
Markup Total		\$ 1,004,614
TOTAL Mark-Up Costs + BASE BID		\$ 4,529,577

Note: Furnishings and Cultural Elements have been listed separately under grant or donor funded items.

Value Engineering Recommendations for Phase 1

Construction Cost	Phase 1: Path+ Plazas	Phase 1: After Deduction	Notes
Site Preparation & Demo	\$ 664,243	\$ 657,267	Reduced boundary of Phase 1
Earthwork	\$ 477,777	\$ 412,672	Reduced boundary of Phase 1
Utilities & Infrastructure	\$ 907,773	\$ 788,071	Moved part of scope to Phase 2
Hardscape and Surface Finishings	\$ 1,065,904	\$ 956,464	Replaced granite pavers with concrete pavers
Site Walls	\$ 247,590	\$ 247,590	
Site Furnishings	\$ 931,278	\$ 554,292	Picnic Tables + Hammocks identified as donor item, added later; reduced swing trellis from 16 to 12, swings have been identified as donor item
Site Stairs and Handrails	\$ 9,068	\$ 9,068	
Site Walls	\$ 247,590	\$ 247,590	
Lighting	\$ 175,881	\$ 175,881	
Ways + Surrounding Landscape	\$ 723,734	\$ 395,024	Moved part of scope to Phase 2
Seating Area	\$ 113,676	\$0	Donor item + added later
Sculpture at West Embayment Plaza	\$ 50,000	\$0	Donor item + added later
Restroom Trailer Relocation	\$ 118,100	\$17,300	Restroom trailer will be demolished and replaced with porta potties in the interim (cost for porta potties has not been included)
BASE BID TOTAL	\$ 4,893,279	\$ 3,490,021	Reduction Total: \$1,403,258
General Conditions/Gen Req's (8%)	\$ 391,462	\$ 279,202	
Insurance + Bond (2%)	\$ 97,866	\$ 69,800	
Design + Pricing Contingency (5%)	\$ 244,664	\$ 174,501	
Construction Contingency (7.5%)	\$ 366,996	\$ 261,752	
Escalation Contingency (4%)	\$ 195,731	\$ 139,601	
Construction Administration (2%)	\$ 97,866	\$ 69,800	
Markup Total	\$ 1,394,584	\$ 994,656	
TOTAL Mark-Up Costs + BASE BID	\$ 6,287,863	\$ 4,484,677	Reduction Total: \$1,803,185
BUDGET	\$ 4,650,000	\$ 4,650,000	
DELTA	\$ 1,637,863	\$ (165,323)	

Note: Sasaki provided a revised Phase 1 cost estimate in September 2022.

Donor Items



Picnic Table and benches



Hammocks



Benches

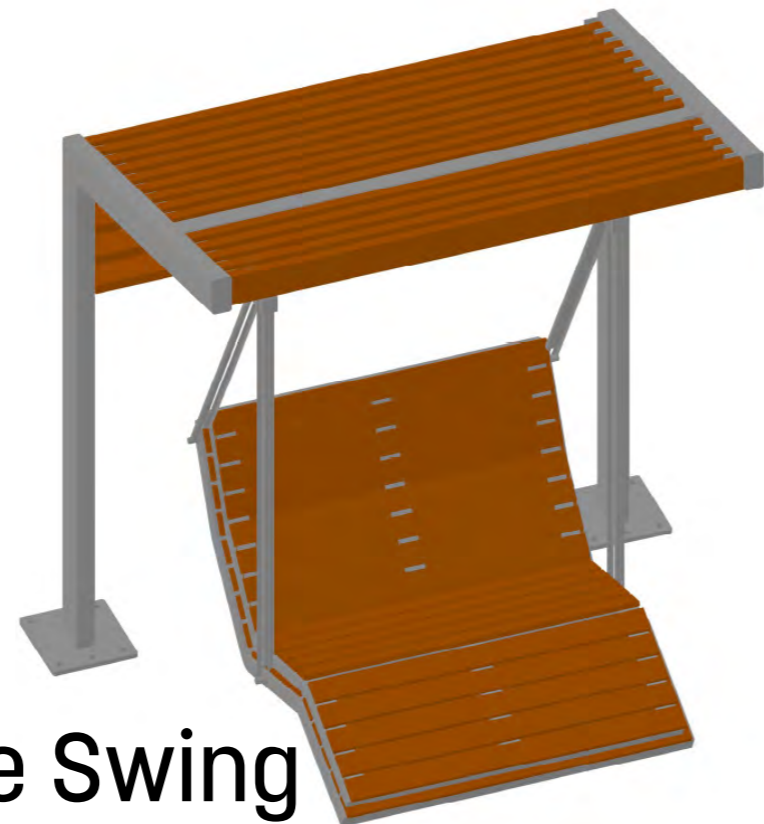

Lounge Swing

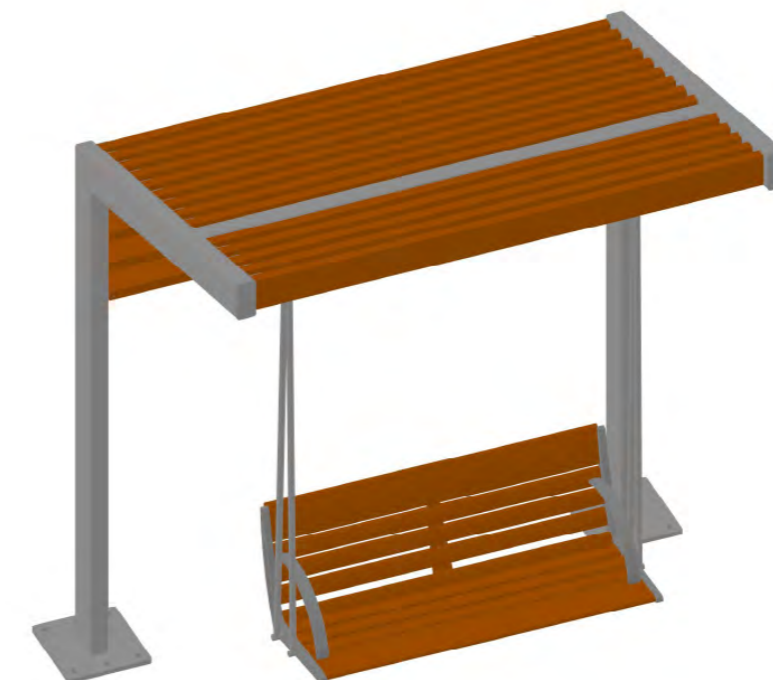

Seat Swing

High Priority Donor/Grant-funded Items: Furnishings

Add Alt #	Item	Quantity	Unit Price	Total
1	Benches	10	\$ 4,015	\$40,150
2	Swing (seat style)	9	\$ 17,109	\$153,981
3	Swing (lounge style)	3	\$ 20,493	\$61,479
4	Picnic Tables	4	\$ 10,925	\$43,700
5	Hammocks	3	\$ 1,954	\$5,862
	Sub-Total			\$305,172
ADDITIONAL COSTS				
1	General Conditions/Gen Req's (8%)			\$24,414
2	Insurance + Bond (2%)			\$6,103
3	Design + Pricing Contingency (5%)			\$15,259
4	Construction Contingency (7.5%)			\$22,888
5	Escalation Contingency (4%)			\$12,207
	Markup Total			\$80,871
TOTAL Mark-Up Costs + Sub-Total				\$386,043

Secondary Donor/Grant-funded Items: Cultural Elements

Add Alt #	Item	Quantity	Unit Price	Total
1	Seating Area	LS	\$ 113,676	\$113,676
2	Sculpture at West Embayment Plaza	Allowance	\$ 50,000	\$50,000
	Sub-Total			\$163,676
ADDITIONAL COSTS				
1	General Conditions/Gen Req's (8%)			\$13,094
2	Insurance + Bond (2%)			\$3,274
3	Design + Pricing Contingency (5%)			\$8,184
4	Construction Contingency (7.5%)			\$12,276
5	Escalation Contingency (4%)			\$6,547
	Markup Total			\$43,374
TOTAL Mark-Up Costs + Sub-Total				\$207,050

Next Steps

Council Approval of Order 385 in order to move into implementation

City to pursue gap funding through donations and grants

Design Team to incorporate feedback + finalize 100% construction documentation | Winter 2022

Permitting | MEPA Review and CH 91 License

Final Detail Design (Shovel Ready) | Winter 2022

Construction Implementation | Beginning Spring 2023

Thank you!



Appendix



Drainage Culvert Cost Estimate

Item No.	Description	Drainage Improvements
CONSTRUCTION COSTS		
A	Site Preparation & Demo	\$ 13,050
B	Earthwork	\$ 53,576
C	Utilities & Infrastructure	\$ 162,150
D	Hardscape and Surface Finishings	\$ 16,451
E	Site Walls	N/A
F	Site Furnishings	N/A
G	Site Stairs and Handrails	N/A
H	Landscaping	N/A
I	Lighting	N/A
J	Special Elements	N/A
K	Visitor Center	N/A
SUB TOTAL (SUM OF A TO D)		\$ 245,227
ALLOWANCE FOR REGULATED SOIL DISPOSAL		\$ 95,945
ALLOWANCE FOR DEWATERING TREATMENT		\$ 100,000
ALLOWANCE FOR UTILITIES		\$ 20,000
BASE BID TOTAL (ALLOWANCES + SUB TOTAL)		\$ 461,172

ADDITIONAL COSTS		
1	General Conditions/Gen Req's (8%)	\$ 36,894
2	Insurance + Bond (2%)	\$ 9,223
3	Design + Pricing Contingency (5%)	\$ 23,059
4	Construction Contingency (7.5%)	\$ 34,588
5	Escalation Contingency (4%)	\$ 18,447
6	Construction Administration (2%)	\$ 9,223
Markup Total		\$ 131,434
TOTAL Mark-Up Costs + BASE BID		
		\$ 592,606

Topography + Views

East Park Section

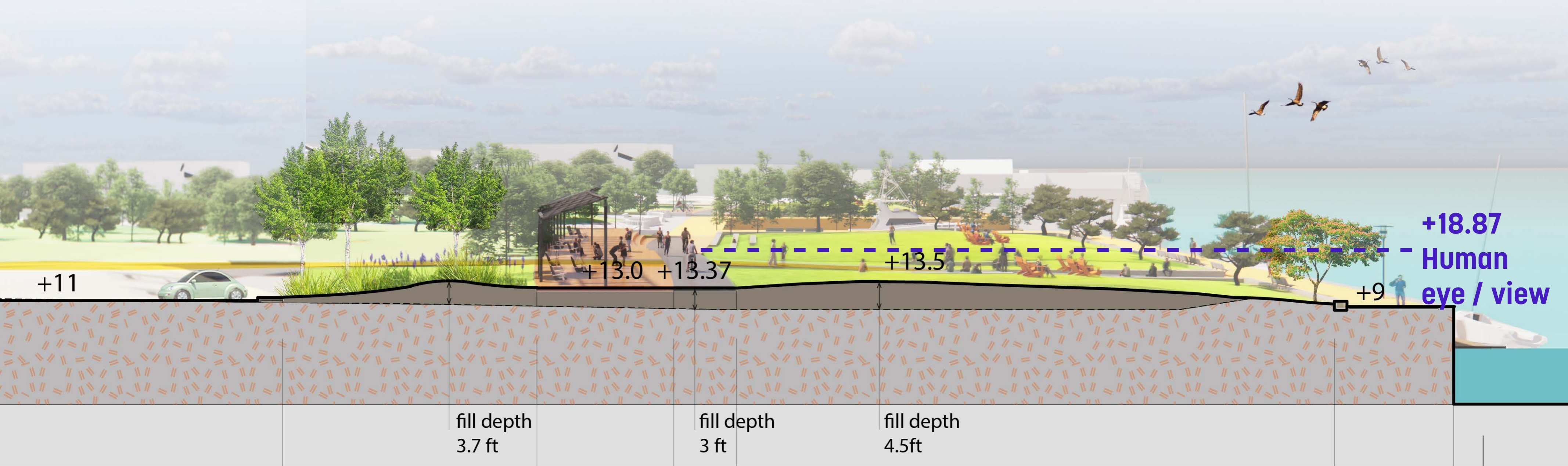



FERRY WHARF PLAZA - WAY VIEW

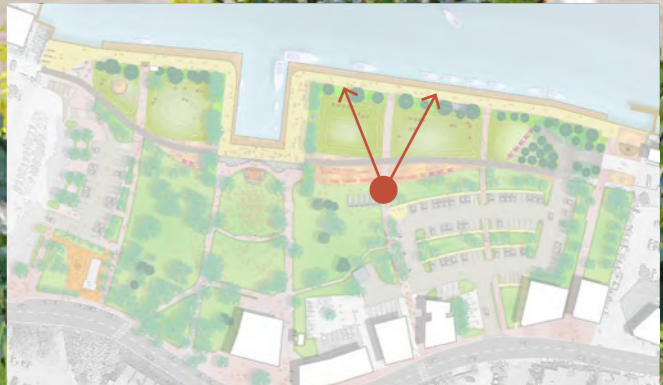

Swing Trellis

Design Alternatives



Poligon Artison
Cost: Medium



Streetlife
Cost: Low



Site Pieces
Cost: High

Swing Trellis

Shade Analysis: June 21st

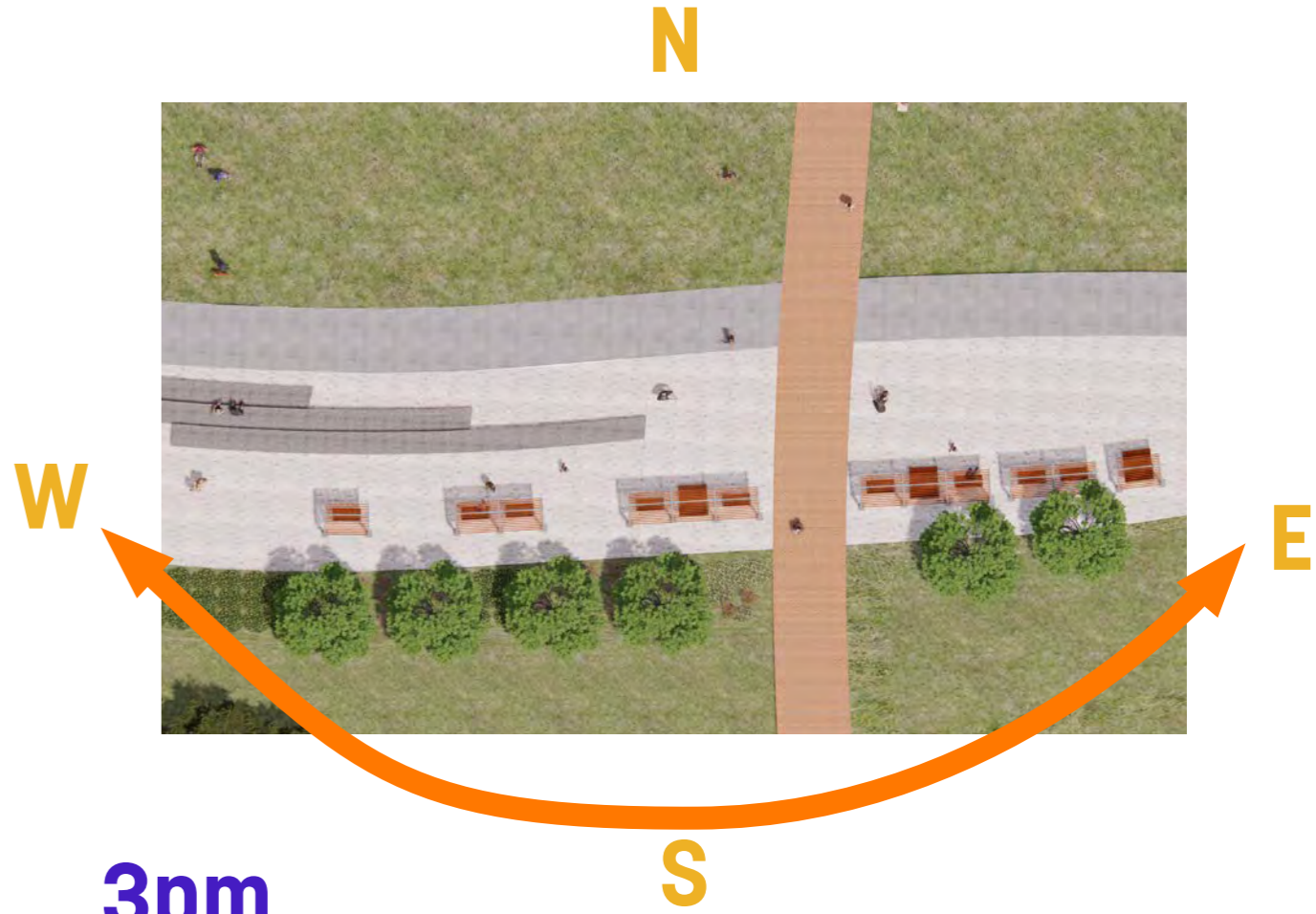

9am



12pm



3pm



Cost Estimate Summary for Phases 1-3

Construction Cost	Phase 1: Path+ Plazas	Phase 2: Parking Lots	Phase1+2	Phase 3: Visitor Center & Plaza	Total Cost
Site Preparation & Demo	\$ 664,243	\$ 258,664	\$ 922,907	\$ 73,481	\$ 1,031,831
Earthwork	\$ 477,777	\$ 17,000	\$ 494,777	\$ 81,557	\$ 824,254
Utilities & Infrastructure	\$ 907,773	N/A	\$ 907,773	\$ 23,382	\$ 1,237,648
Hardscape and Surface Finishings	\$ 1,065,904	\$ 747,668	\$ 1,813,572	\$ 349,756	\$ 2,219,779
Site Walls	\$ 247,590	N/A	\$ 247,590	\$ 114,926	\$ 362,516
Site Furnishings	\$ 931,278	\$ 63,944	\$ 995,222	\$ 44,674	\$ 1,039,897
Site Stairs and Handrails	\$ 9,068	N/A	\$ 9,068	\$ 30,595	\$ 39,663
Landscaping	\$ 265,926	\$ 157,622	\$ 423,548	\$ 50,932	\$ 474,480
Lighting	\$ 175,881	\$ 103,873	\$ 279,754	\$ 10,939	\$ 290,693
Special Elements	\$ 147,840	N/A	\$ 147,840	N/A	\$ 147,840
Visitor Center	N/A	N/A	N/A	\$ 969,147	\$ 969,147
BASE BID TOTAL	\$ 4,893,279	\$ 1,348,771	\$ 6,242,049	\$ 1,749,389	\$ 7,991,439
General Conditions/Gen Req's (8%)	\$ 391,462	\$ 107,902	\$ 499,364	\$ 139,951	\$ 691,020
Insurance + Bond (2%)	\$ 97,866	\$ 26,975	\$ 124,841	\$ 34,988	\$ 172,755
Design + Pricing Contingency (5%)	\$ 244,664	\$ 67,439	\$ 312,102	\$ 87,469	\$ 431,887
Construction Contingency (7.5%)	\$ 366,996	\$ 101,158	\$ 468,154	\$ 131,204	\$ 647,831
Escalation Contingency (4%)	\$ 195,731	\$ 53,951	\$ 249,682	\$ 185,435	\$ 460,970
Construction Administration (2%)	\$ 97,866	\$ 26,975	\$ 124,841	\$ 34,988	\$ 172,755
Markup Total	\$ 1,394,584	\$ 384,400	\$ 1,778,984	\$ 614,036	\$ 2,577,217
TOTAL Mark-Up Costs + BASE BID	\$ 6,287,863	\$ 1,733,170	\$ 8,021,033	\$ 2,363,425	\$ 10,568,656
Schematic Cost Estimate			\$ 5,100,000	\$ 1,670,000	\$ 6,770,000

Phase 1 + 2



Phase 1, 2 +3



Events + Programming

