

PROPOSED SITE PLAN FOR 3 NEWBURYPORT TURNPIKE IN NEWBURY, MA

JULY 15, 2020

DATE

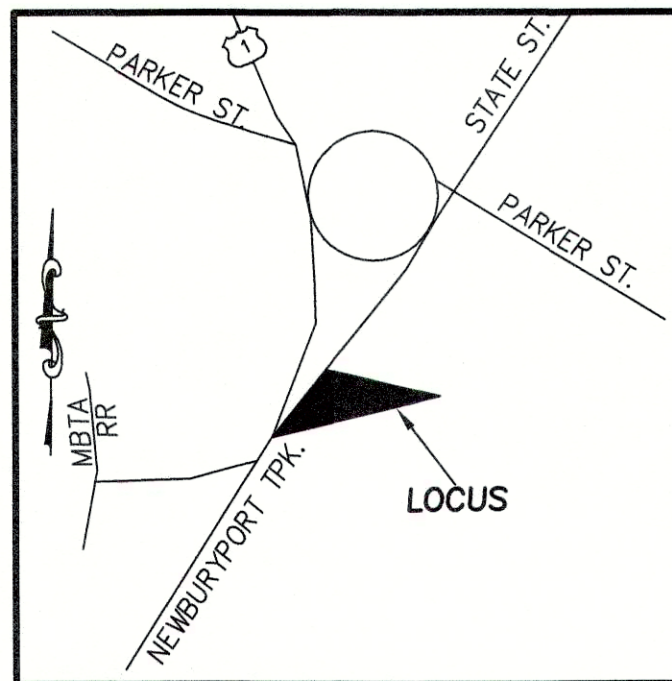

LOCUS MAP
N.T.S.

ZONING TABLE

3 NEWBURYPORT TURNPIKE - ASSESSORS MAP 39 LOT R47 ZONING DISTRICT BJ1			
	REQUIRED	EXISTING	PROPOSED
LOT AREA:	40,000 S.F.	72,774 S.F.	72,774 S.F.
LOT FRONTAGE:	200 FT.	339.71 FT.	339.71 FT.
FRONT SETBACK:	50 FT.*	**	50.5 FT.
SIDE SETBACK:	25 FT.	**	30.7 FT.
REAR SETBACK:	25 FT.	**	NA
LOT COVERAGE:	50% (MAX)	**	29.8%
OPEN SPACE:	**	**	**
BLDG HEIGHT:	35 FT.	**	**

*50 FEET MEASURED FROM STREET LINE. FRONT PROPERTY LINE SETBACK IS 25 FEET
1. THIS SITE IS LOCATED WITHIN THE WATER SUPPLY PROTECTION DISTRICT

PLAN INDEX

SHEET NO.	TITLE
1	COVER SHEET
2	EXISTING CONDITIONS
3	SITE PLAN
4	GRADING PLAN
5-7	CONSTRUCTION DETAILS
E-1	LIGHTING PLAN
L-1	LANDSCAPE PLAN

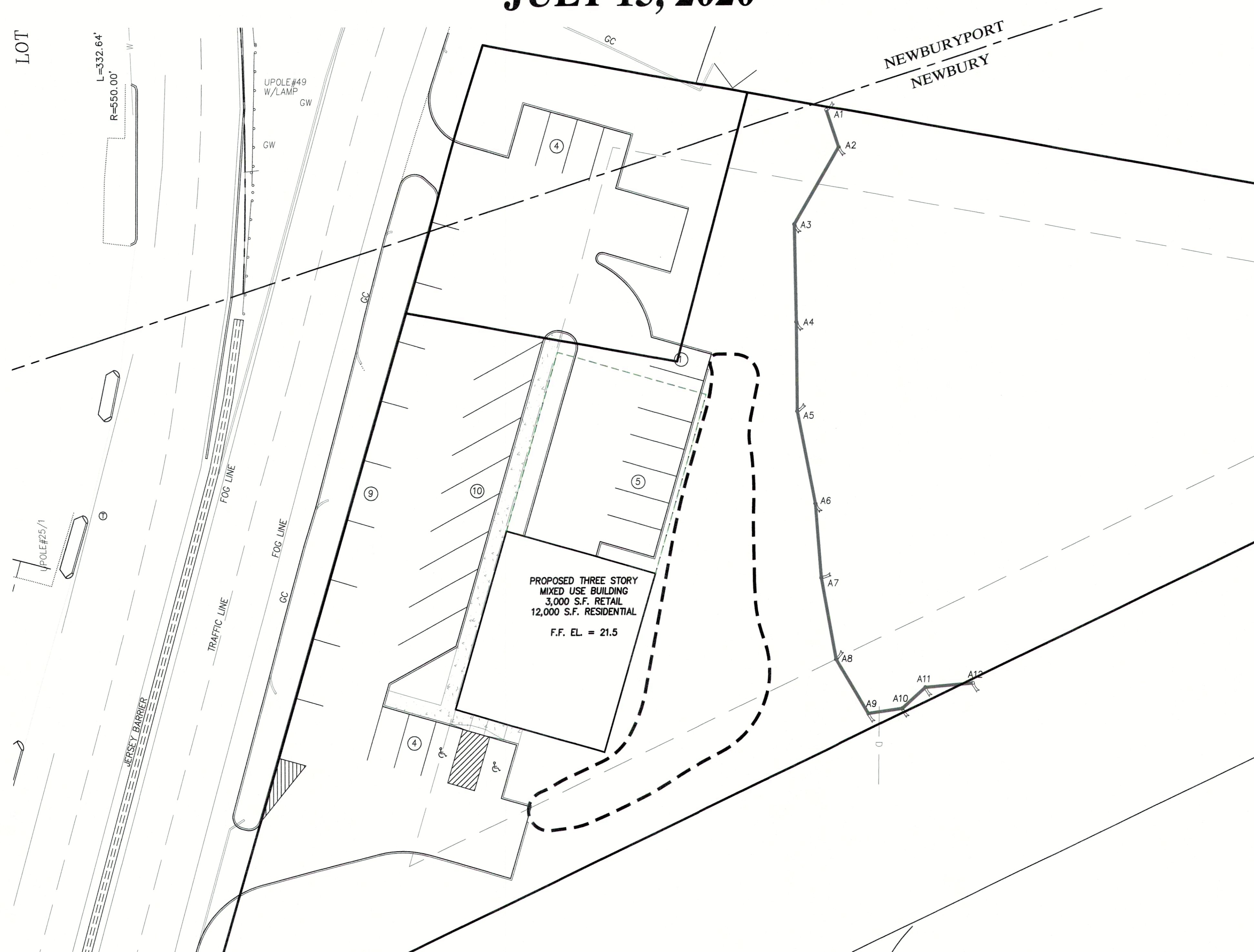

OWNER OF RECORD
BAVARO FAMILY REALTY TRUST, LLC
BK. 37234 PG. 197
#3 NEWBURYPORT TURNPIKE

<p>GRAPHIC SCALE</p> <p>(IN FEET) 1 inch = 20'</p>		<p>PREPARED FOR</p> <p>BAVARO FAMILY REALTY TWO, LLC 18 GRAF ROAD UNIT #31 NEWBURYPORT, MA</p>	<table border="1"> <thead> <tr> <th>NO.</th> <th>DATE</th> <th>DESCRIPTION</th> <th>BY</th> </tr> </thead> <tbody> <tr> <td> </td> <td> </td> <td> </td> <td> </td> </tr> </tbody> </table>	NO.	DATE	DESCRIPTION	BY					<p>MILLENNIUM ENGINEERING, INC. ENGINEERING AND LAND SURVEYING 62 ELM ST. SALISBURY, MA 01952 (978) 463-8980 13 HAMPTON RD. EXETER, NH 03833 (603) 778-0528</p> <p>SCALE: 1"=20' DATE: JULY 15, 2020</p> <p>DESG. BY: C.M.Y. CHKD. BY: E.W.B.</p> <p>PROJECT: M193668</p>	<p>SITE PLAN IN NEWBURY, MA SHOWING PROPOSED SITE IMPROVEMENTS AT 3 NEWBURYPORT TURNPIKE</p>	<p>COVER SHEET</p> <p>SHEET: 1 OF 7</p>
NO.	DATE	DESCRIPTION	BY											

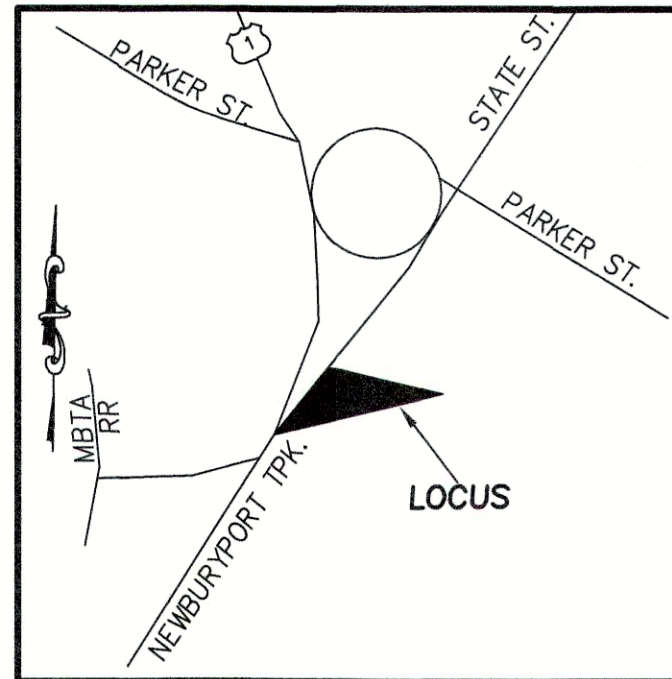

LOCUS MAP
N.T.S.

ZONING DISTRICT - BLI
 REQUIRED SETBACKS
 FRONT 50
 SIDE 25
 REAR 25

BASIS OF BEARINGS
 PLAN BK. 110 PLAN 22
OWNER OF RECORD
 BAVARO FAMILY REALTY TWO, LLC
 BOOK 37234 - PAGE 197

PLAN REFERENCES
 LOCUS: PLAN BK. 110 PLAN 22

- NEWBURY LAYOUTS**
- NEWBURY - JAN. 10, 1923
LAYOUT NO. 1994
SHT. 1 OF 3
SHT. 3 OF 3
 - NEWBURY - JAN. 10, 1923
LAYOUT NO. 3095
DOCUMENT AND ORDER OF TAKING
 - NEWBURY - FEB. 11, 1936
LAYOUT NO. 3181
SHTS. 1 & 2 OF 2
 - NEWBURY - FEB. 11, 1936
LAYOUT NO. 3182
ONE SHEET
 - NEWBURY - 1970
ALTERATION
LAYOUT NO. 5823
SHT. 2 OF 2
 - NEWBURY - 1993
ALTERATION
LAYOUT NO. 7130
SHTS. 1 & 2 OF 2

- NEWBURYPORT LAYOUTS**
- NEWBURYPORT - JULY 16, 1918
LAYOUT NO. 1795
SHT. 1 OF 2
 - NEWBURYPORT - MARCH 13, 1934
LAYOUT NO. 3091
SHT. 1 OF 4
 - NEWBURYPORT - MARCH 13, 1934
LAYOUT NO. 3093
ONE SHEET
 - PLAN NO. 222 OF 1943
 - PLAN NO. 244 OF 1945

NOTES:

THIS PLAN DOES NOT SHOW ANY UNRECORDED OR UNWRITTEN EASEMENTS WHICH MAY EXIST. A REASONABLE AND DILIGENT ATTEMPT HAS BEEN MADE TO OBSERVE ANY APPARENT, VISIBLE USES OF THE LAND; HOWEVER, THIS DOES NOT CONSTITUTE A GUARANTEE THAT NO SUCH EASEMENTS EXIST.

RECORD UTILITY INFORMATION HAS NOT BEEN OBTAINED FOR LOCUS. VISIBLE SURFACE STRUCTURES HAVE BEEN LOCATED AND ARE SHOWN HEREON HOWEVER, SUBSURFACE UTILITY LINES ARE NOT SHOWN.

THE CERTIFICATIONS SHOWN HEREON ARE NOT INTENDED AS CERTIFICATION TO TITLE OR OWNERSHIP OF PROPERTY SHOWN. OWNERS OF ADJOINING PROPERTIES ARE ACCORDING TO CURRENT CITY OF NEWBURYPORT AND TOWN OF NEWBURY ASSESSORS RECORDS.

I CERTIFY:
 THAT THIS ACTUAL SURVEY WAS MADE ON THE GROUND DECEMBER 19, 2019, AND THAT THE STRUCTURES AND PHYSICAL FEATURES ARE LOCATED AS SHOWN TO THE BEST OF MY ABILITY AND BELIEF.

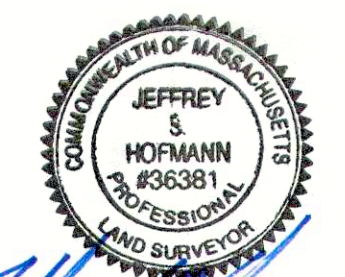

PROFESSIONAL LAND SURVEYOR DATE 7/15/20

- LEGEND**
- C.B. CONCRETE BOUND
 - S.B. STONE BOUND
 - D.H. DRILL HOLE
 - PK MASONRY NAIL
 - I.P. IRON PIPE
 - I. ROD IRON ROD
 - FND. FOUND
 - N/F. NOW OR FORMERLY
 - ASSESSORS MAP#
 - PARCEL#
 - N/F NAME BK & PG

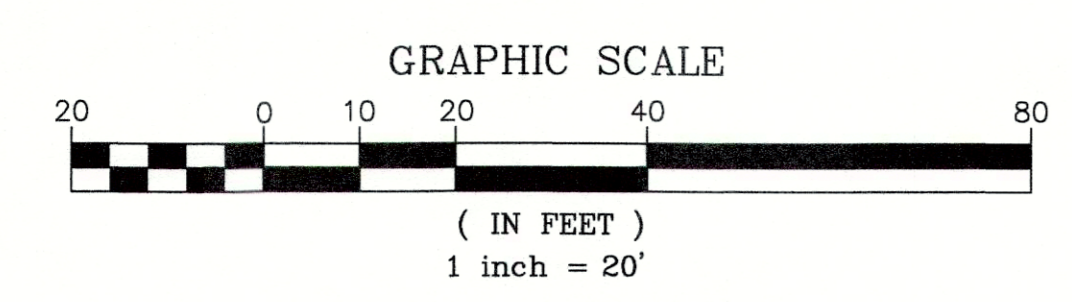
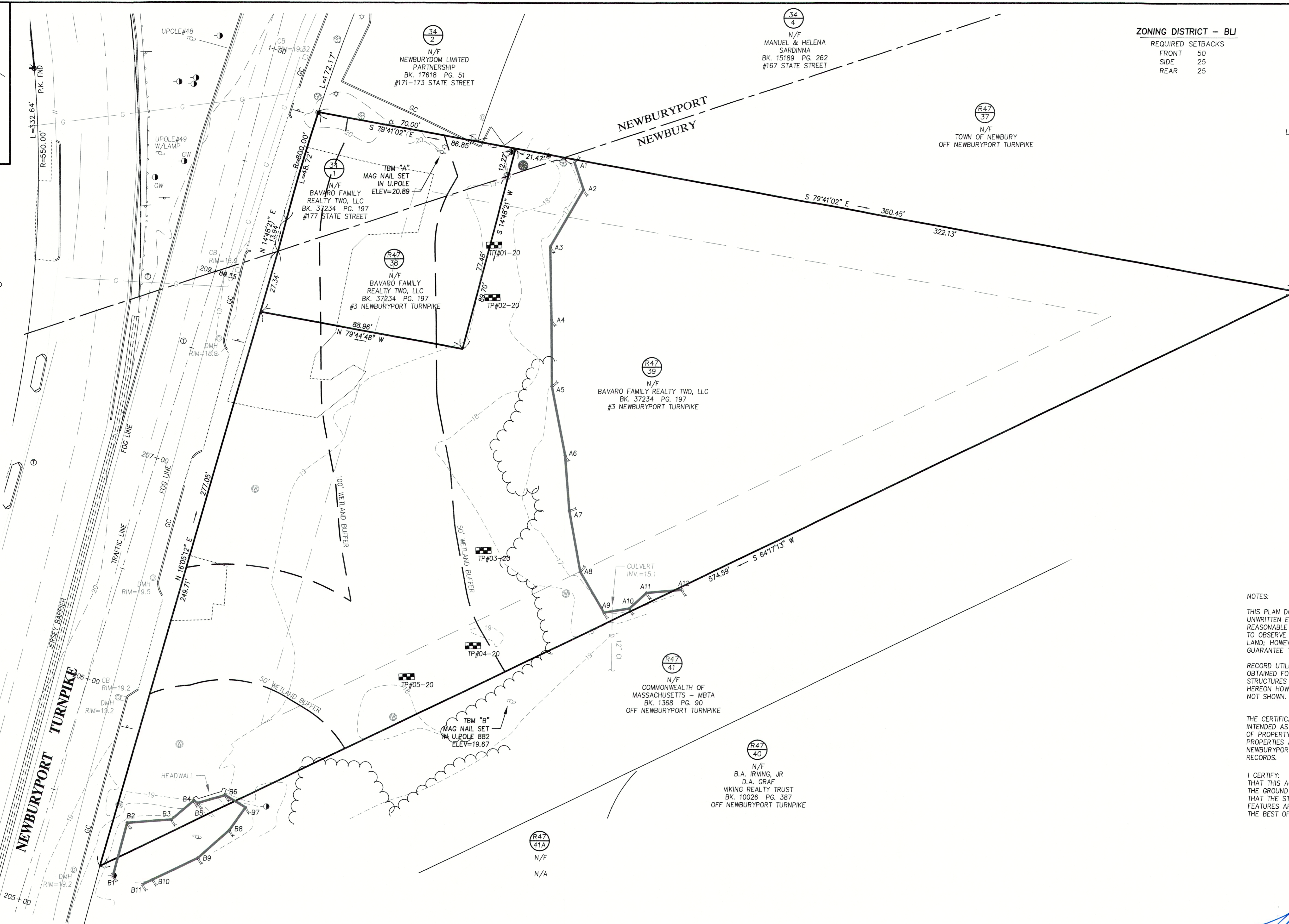

PREPARED FOR
BAVARO FAMILY REALTY TWO, LLC
 18 GRAF ROAD - UNIT 31
 NEWBURYPORT, MA 01950

NO.	DATE	DESCRIPTION	BY

MILLENNIUM ENGINEERING, INC.
 ENGINEERING AND LAND SURVEYING
 62 ELM ST. SALISBURY, MA 01952 (978) 463-8980
 13 HAMPTON RD. EXETER, NH 03833 (603) 778-0528

SCALE: 1"=20'
 DATE: JULY 15, 2020
 CALC. BY: P.D.B.
 CHKD. BY: J.S.H.
 PROJECT: M193668

PLAN OF LAND
 IN
NEWBURY, MA
 SHOWING
 EXISTING CONDITIONS
 AT
3 NEWBURYPORT TURNPIKE

EXISTING CONDITIONS
 SHEET: 2 OF 7

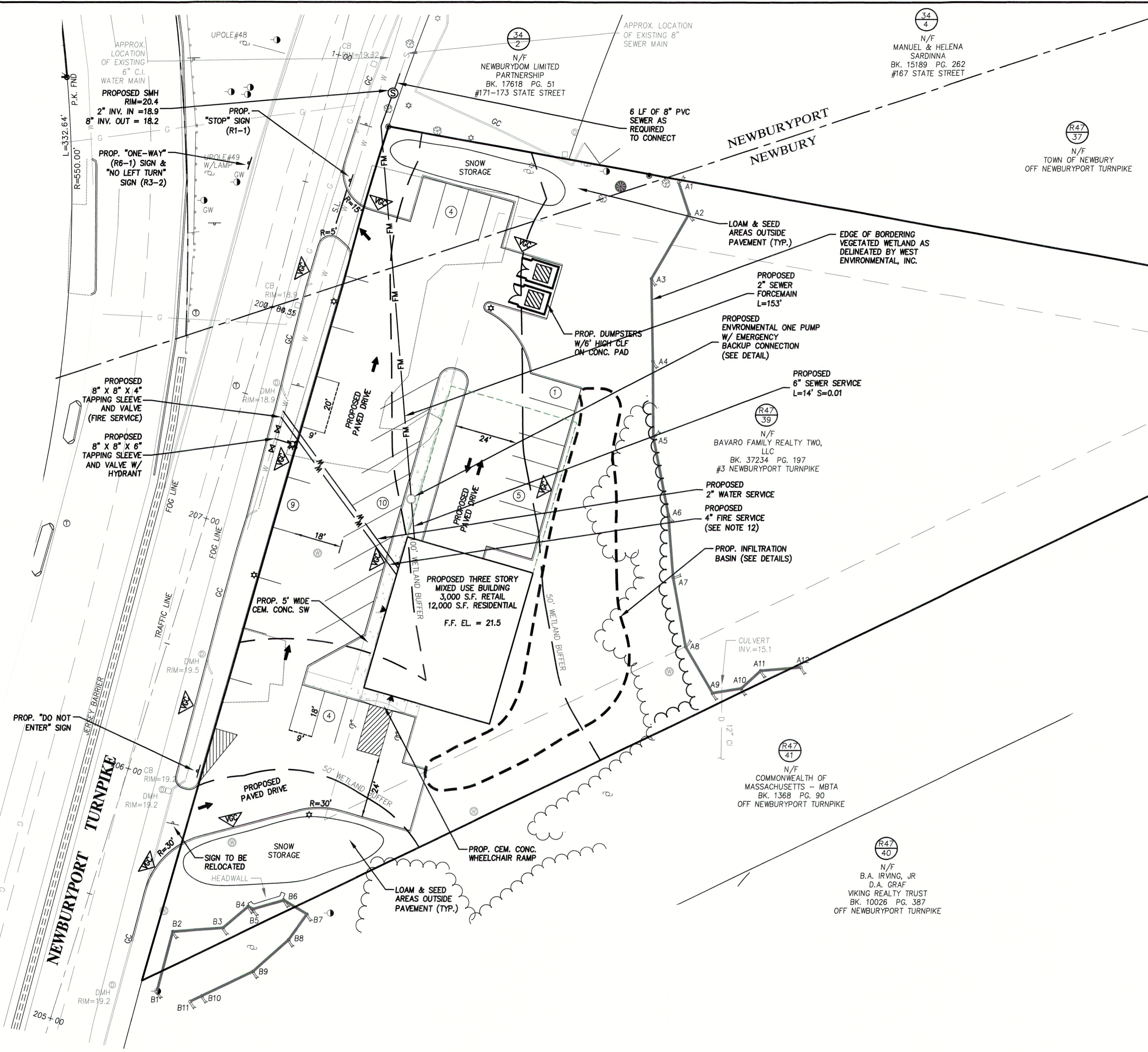

LEGEND

- 110— EXIST. CONTOUR
- 111— PROP. CONTOUR
- PROP. RETAINING WALL
- D— PROP. DRAIN LINE
- RD— PROP. PERFORATED ROOF DRAIN
- UE— PROP. UNDERGROUND ELECTRIC
- PROP. CATCH BASIN
- EXIST. CATCH BASIN
- EXIST. UTILITY POLE
- ◀ PROP. BUILDING LIGHT
- ◻ WETLANDS
- ◻ PROP. BIT. CONC. CURB

PARKING SPACE CALCS.

USE	# OF SPACES REQUIRED
MIXED RETAIL	3 SPACES PER 1,000 S.F. GFA
RESIDENTIAL	2 SPACES PER UNIT
RETAIL	3,000 S.F. GFA
	# OF SPACES REQUIRED = 9
RESIDENTIAL	12 UNITS
	# OF SPACES REQUIRED = 24
TOTAL # OF SPACES REQUIRED	= 33
TOTAL # OF SPACES PROVIDED	= 33

GENERAL NOTES

- ALL WORK SHALL CONFORM TO; THE NEWBURY PLANNING BOARD RULES AND REGULATIONS GOVERNING THE SUBDIVISION OF LAND, THE WETLANDS PROTECTION ACT (310 CMR 10.00), THE ORDER OF CONDITIONS ISSUED BY THE NEWBURY CONSERVATION COMMISSION, AND THESE PLANS.
- THE CONTRACTOR SHALL REPORT TO THE OWNER AND ENGINEER ANY SIGNIFICANT VARIATIONS IN EXISTING SITE CONDITIONS. ANY PROPOSED REVISIONS TO THE WORK SHALL NOT BE UNDERTAKEN UNTIL REVIEWED AND APPROVED BY THE OWNER AND REGULATING MUNICIPAL AND/OR STATE AGENCIES.
- THE LOCATION OF ALL UTILITIES, AS SHOWN ON THESE PLANS, ARE BASED UPON PLANS AND RECORD INFORMATION PROVIDED BY MUNICIPAL AND PRIVATE UTILITY COMPANIES AND ARE CONSIDERED APPROXIMATE BOTH AS TO SIZE AND LOCATION. NO WARRANTY IS MADE TO THE ACCURACY OF THESE LOCATIONS OR THAT ALL UTILITIES ARE SHOWN. THE CONTRACTOR SHALL NOT RELY ON THESE PLANS FOR SUCH INFORMATION AND SHALL MAKE EXAMINATIONS IN THE FIELD BY VARIOUS AVAILABLE RECORDS, UTILITY COMPANIES AND INDIVIDUALS, AS TO THE LOCATION OF ALL SUBSURFACE STRUCTURES.
- THE CONTRACTOR SHALL FIELD CHECK ALL DIMENSIONS AND ELEVATIONS BEFORE PROCEEDING WITH THE NEW WORK. HE/SHE SHALL EXCAVATE TO VERIFY PERTINENT DRAINAGE INVERTS AND POTENTIAL UTILITY CONFLICTS. ANY DISCREPANCIES SHALL BE REPORTED TO THE OWNER IMMEDIATELY.
- THE CONTRACTOR IS RESPONSIBLE FOR INITIATING, MAINTAINING, AND SUPERVISING ALL SAFETY PRECAUTIONS AND PROGRAMS IN CONNECTION WITH THE WORK. THE CONTRACTOR SHALL TAKE ALL NECESSARY PRECAUTIONS FOR THE SAFETY OF THE PUBLIC, EMPLOYEES, AND ALL OTHER PERSONS ASSOCIATED WITH THE PROJECT. HE/SHE SHALL COORDINATE AND BE RESPONSIBLE FOR ALL SAFETY SIGNING, BARRIERS AND TEMPORARY PAVEMENT MARKINGS NECESSARY TO PROVIDE A SMOOTH AND PROPER TRANSITION FOR TRAFFIC FLOW.
- THE CONTRACTOR SHALL VERIFY THE LOCATION OF EXISTING UTILITIES BY CONTACTING "DIG-SAFE" AT LEAST 72 HOURS PRIOR TO ANY EXCAVATION. DIG-SAFE TELEPHONE NUMBER: 1-888-344-7233.
- 14 DAYS PRIOR TO COMMENCING CONSTRUCTION, THE OWNER/DEVELOPER SHALL PRESENT A CONSTRUCTION SCHEDULE TO THE PLANNING DEPARTMENT.
- TWO HARD COPIES OF AS-BUILT DRAWINGS SHALL BE SUBMITTED TO THE PLANNING DEPARTMENT UPON COMPLETION OF THE PROJECT. AS-BUILTS SHALL INCLUDE ALL LANDBASE AND UTILITIES INFORMATION.
- ONSITE BURIAL OF STUMPS OR ANY OTHER DEBRIS IS PROHIBITED.
- THE PROPERTY DOES NOT LIE WITHIN THE 100-YEAR FLOOD PLAIN ACCORDING TO F.I.R.M. COMMUNITY PANEL NUMBER 25009C0117G.
- ELEVATIONS ARE BASED UPON AN 1988 NAV DATUM.
- SIZE AND LOCATION OF THE FIRE SERVICE TO BE DESIGNED BY A FIRE PROTECTION DESIGNER.
- WATER AND SEWER MAINS SHOWN ARE APPROXIMATE. FURTHER INFORMATION IS REQUIRED FROM NEWBURYPORT DPS PRIOR TO CONSTRUCTION TO VERIFY SIZE AND LOCATION OF THESE UTILITIES.

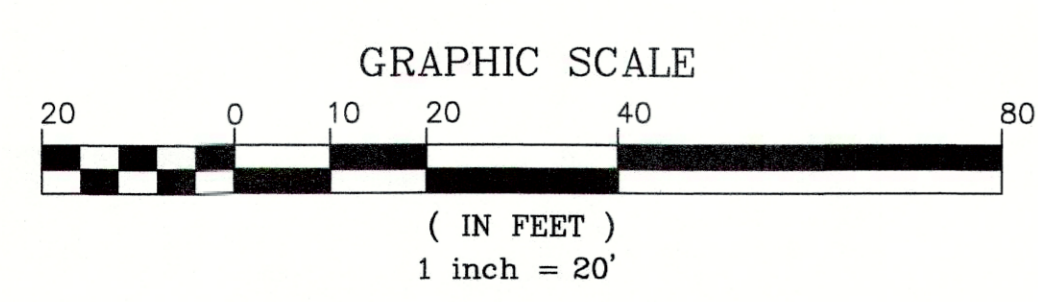

PREPARED FOR
BAVARO FAMILY REALTY TWO, LLC
 18 GRAF ROAD UNIT #31
 NEWBURYPORT, MA

NO.	DATE	DESCRIPTION	BY

MEI **MILLENNIUM ENGINEERING, INC.**
 ENGINEERING AND LAND SURVEYING
 62 ELM ST. SALISBURY, MA 01952 (978) 463-8980
 13 HAMPTON RD. EXETER, NH 03833 (603) 778-0528

SCALE: 1"=20'
 DATE: JULY 15, 2020

DES. BY: C.M.Y.
 CHKD. BY: E.W.B.

PROJECT: M193668

SITE PLAN
 IN
NEWBURY, MA
 SHOWING
PROPOSED SITE IMPROVEMENTS
 AT
3 NEWBURYPORT TURNPIKE

SITE PLAN
 SHEET: 3 OF 7

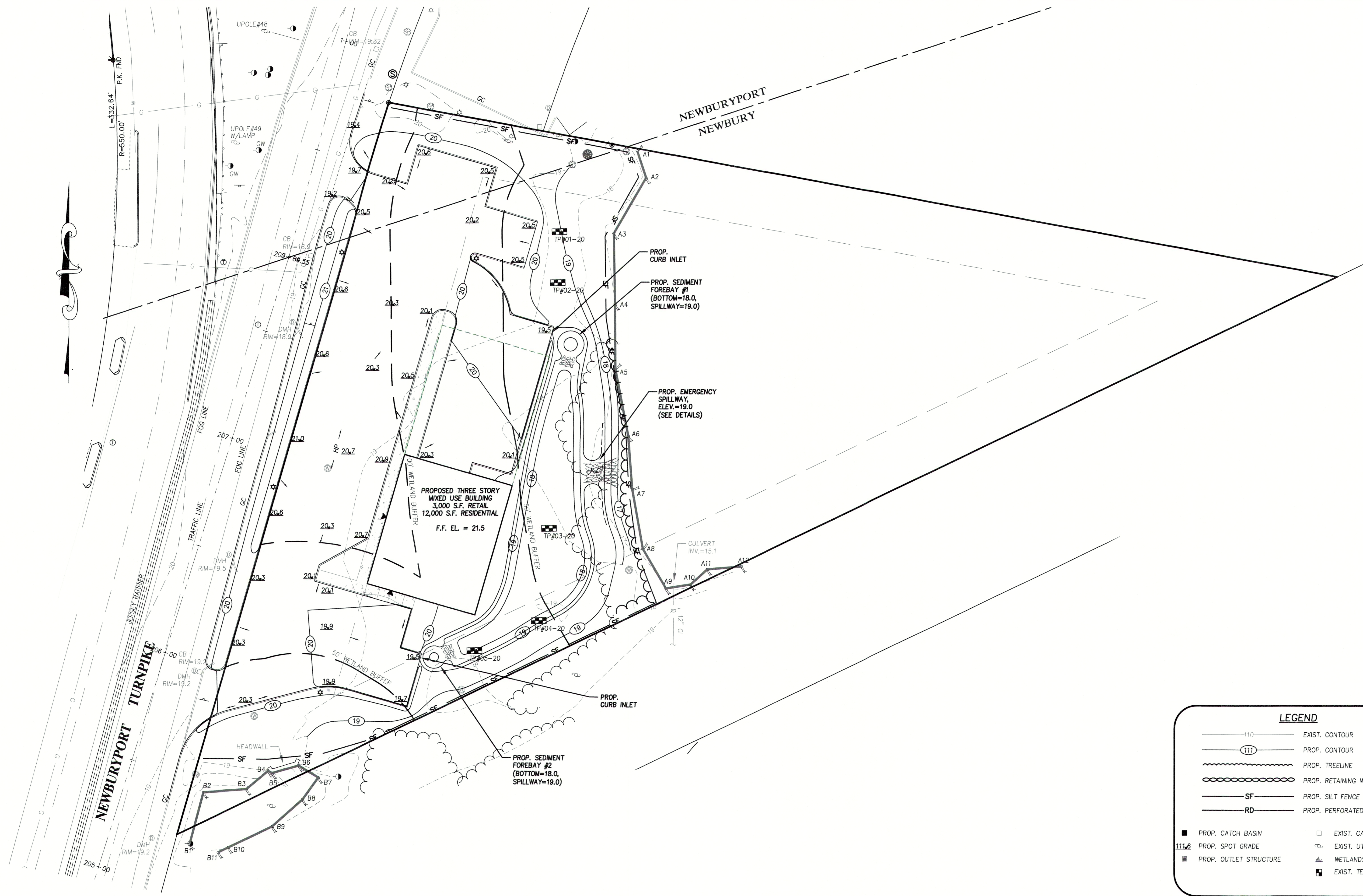

LEGEND	
	EXIST. CONTOUR
	PROP. CONTOUR
	PROP. TREELINE
	PROP. RETAINING WALL
	PROP. SILT FENCE
	PROP. PERFORATED ROOF DRAIN
	PROP. CATCH BASIN
	PROP. SPOT GRADE
	PROP. OUTLET STRUCTURE
	EXIST. CATCH BASIN
	EXIST. UTILITY POLE
	WETLANDS
	EXIST. TEST PIT

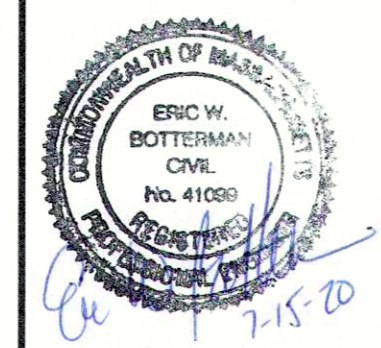
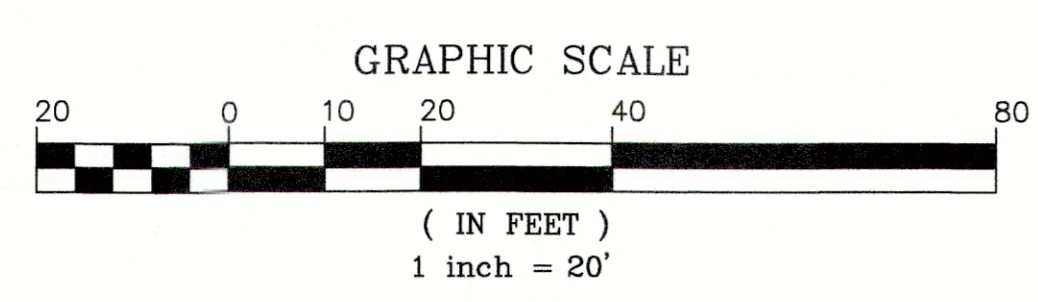

PREPARED FOR
BAVARO FAMILY REALTY TWO, LLC
 18 GRAF ROAD UNIT #31
 NEWBURYPORT, MA

MILLENNIUM ENGINEERING, INC.
 ENGINEERING AND LAND SURVEYING
 62 ELM ST. SALISBURY, MA 01952 (978) 463-8980
 13 HAMPTON RD. EXETER, NH 03833 (603) 778-0528

SITE PLAN
 IN
NEWBURY, MA
 SHOWING
PROPOSED SITE IMPROVEMENTS
 AT
3 NEWBURYPORT TURNPIKE

GRADING PLAN
 SHEET: 4 OF 7

NO.	DATE	DESCRIPTION	BY

SCALE: 1"=20'
 DATE: JULY 15, 2020
 DESG. BY: C.M.Y.
 CHKD. BY: E.W.B.
 PROJECT: M193668

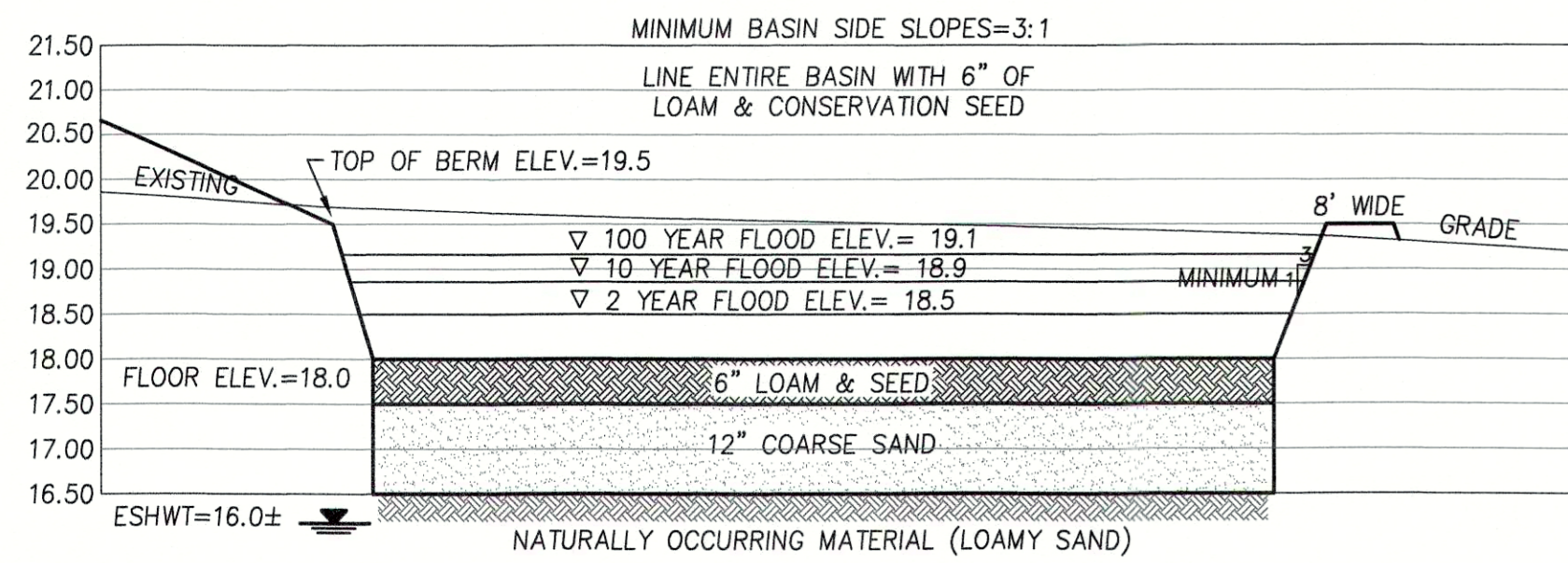

INFILTRATION BASIN
TYP. CROSS-SECTION HORIZ. SCALE: N.T.S.
 VERT. SCALE: 1"=2'

CONSTRUCTION SPECIFICATIONS

- BERMS SHALL BE CONSTRUCTED OF FILL MATERIAL FREE OF ROOTS, STUMPS, WOOD, RUBBISH, STONES GREATER THAN 6", OR OTHER OBJECTIONABLE MATERIALS. FILL MATERIAL FOR THE CENTER OF THE BERM SHALL CONFORM TO UNIFIED SOIL CLASSIFICATION GC, SC, CH, OR CL AND HAVE AT LEAST 30% PASSING THE #200 SIEVE. MATERIALS USED IN THE OUTER SHELL OF THE BERMS SHALL BE CAPABLE OF SUPPORTING THE VEGETATION SPECIFIED ON THE PLANS.
- FILL MATERIALS SHALL BE PLACED IN MAXIMUM 8-INCH LIFTS AND COMPACTED WITH A MINIMUM REQUIRED DENSITY OF NOT LESS THAN 95% OF MAXIMUM DRY DENSITY.
- PRIOR TO FILL MATERIAL INSTALLATION, ALL TOPSOIL, SUBSOIL, AND UNSUITABLE MATERIAL SHALL BE REMOVED AND REPLACED WITH SUITABLE MATERIAL.
- AFTER THE INFILTRATION BASIN IS EXCAVATED TO THE FINAL DESIGN ELEVATION, THE FLOOR SHALL BE DEEPLY TILLED WITH A ROTARY TILLER OR DISC HARROW TO RESTORE INFILTRATION RATES, FOLLOWED BY A PASS WITH A LEVELING DRAG.
- EROSION CONTROL MATTING SHALL BE INSTALLED ON ALL OUTSIDE SLOPES OF STORMWATER BASINS. MATTING SHALL BE A WOVEN JUTE MESH MANUFACTURED BY MACCAFERRI COMPANY, OR APPROVED EQUAL.
- THE INFILTRATION BASIN BOTTOM SHALL BE CONSTRUCTED OF 6" LOAM & CONSERVATION SEED OVER A 12" LAYER OF COARSE SAND.

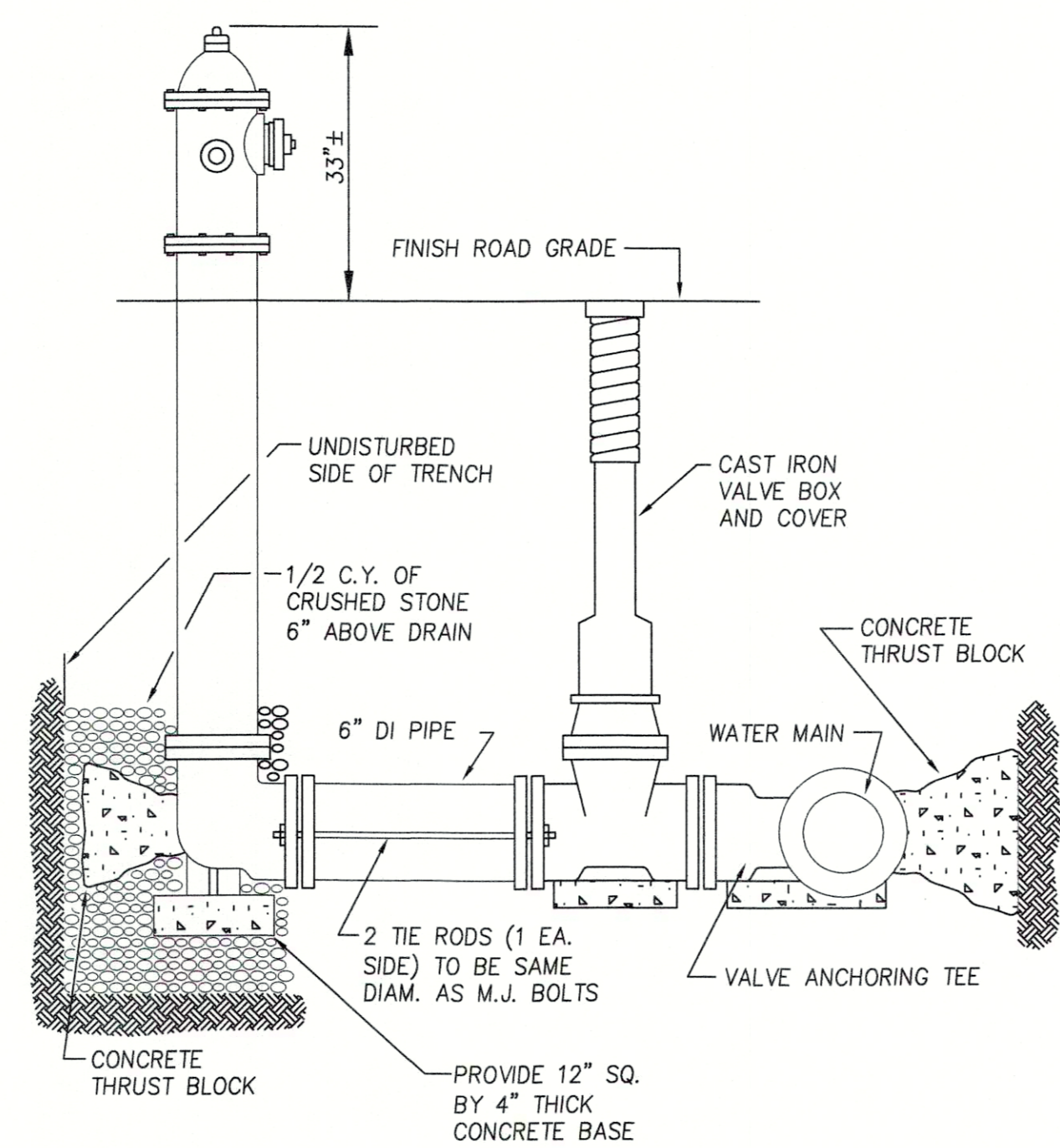

TYPICAL FIRE HYDRANT INSTALLATION N.T.S.

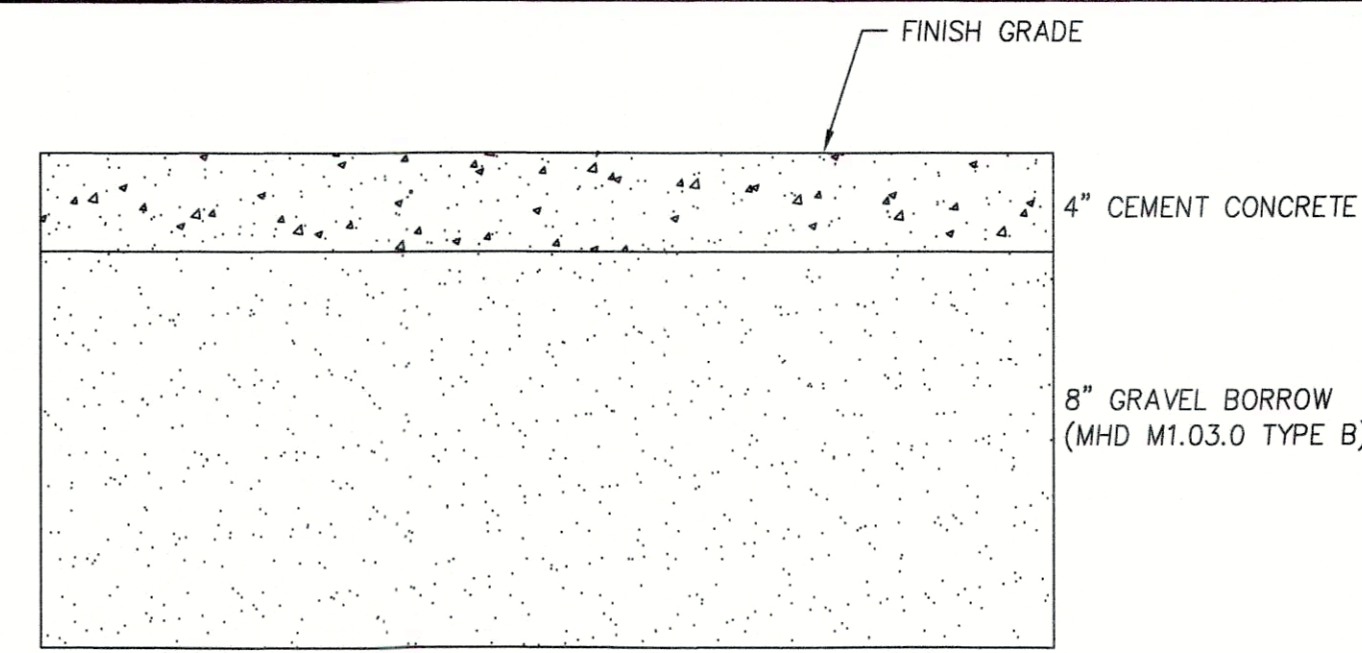

CONCRETE SIDEWALK DETAIL N.T.S.

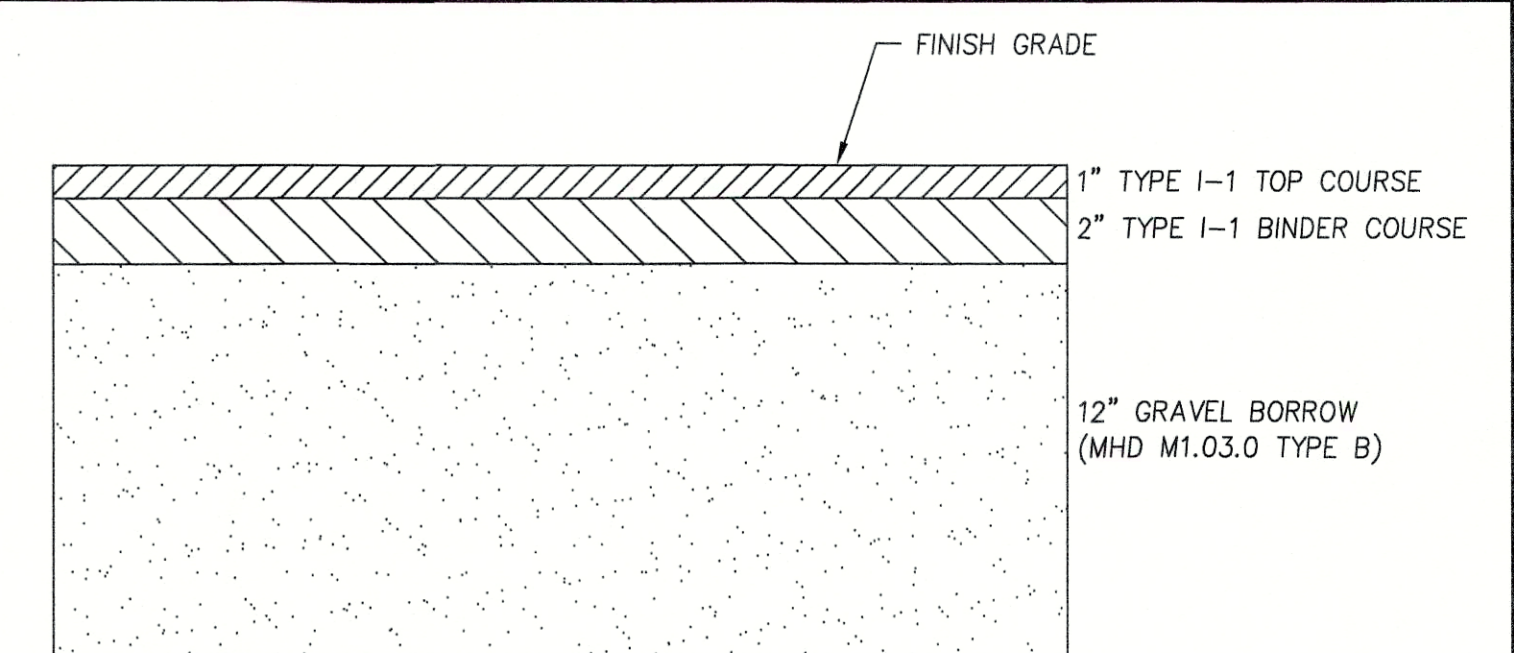

PAVEMENT DETAIL N.T.S.

PAVEMENT NOTES

- ALL STUMPS, ROCKS AND LEDGE WITHIN THE LIMITS OF THE PROPOSED PAVED WAY SHALL BE REMOVED. ALL LEDGE SHALL BE REMOVED TO A MINIMUM DEPTH OF 2' BELOW FINISHED PAVEMENT GRADE.
- PAVEMENT SHALL NOT BE CONSTRUCTED DURING FREEZING WEATHER OR ON WET OR FROZEN SUBGRADE.
- GRADING AND ROLLING SHALL BE REQUIRED TO PROVIDE A SMOOTH, EVEN, AND UNIFORM COMPACTED BASE WHICH IS COMPACTED TO A MINIMUM DRY DENSITY OF 95 PERCENT.
- ALL UNSUITABLE MATERIAL SHALL BE EXCAVATED AND REPLACED WITH SATISFACTORY MATERIAL AND BROUGHT UP TO GRADE WITH GRAVEL BORROW CONTAINING NO STONES GREATER THAN 6" DIAMETER.
- AT ALL TIMES DURING CONSTRUCTION, THE SUB-GRADE AND ALL DITCHES SHALL BE CONSTRUCTED AND MAINTAINED SO THAT THE TRACK WILL EFFECTIVELY BE DRAINED.
- THE CONTRACTOR SHALL REFER TO THE NEWBURY PLANNING BOARD RULES AND REGULATIONS GOVERNING THE SUBDIVISION OF LAND, ARTICLES I - VIII.

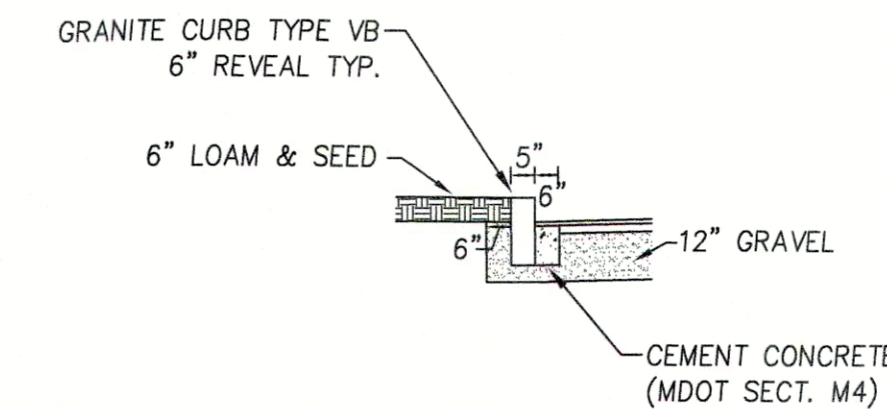

TYPICAL GRANITE CURBING INSTALLATION DETAIL N.T.S.

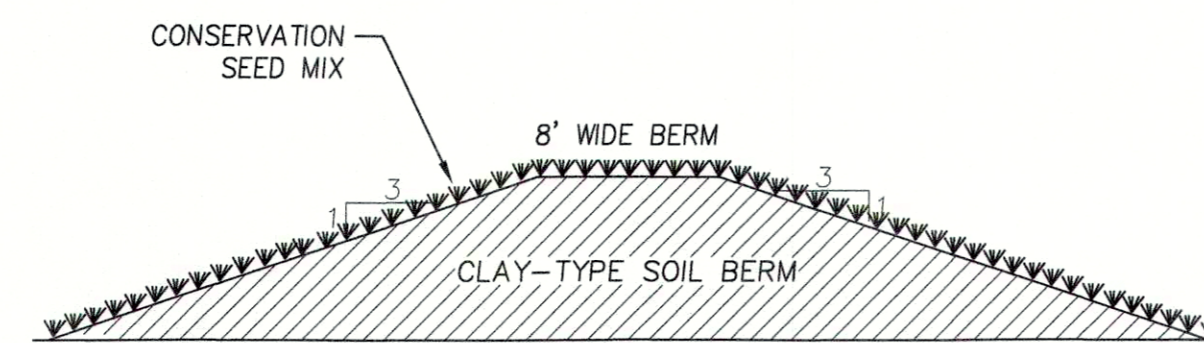

INFILTRATION BASIN BERM DETAIL N.T.S.

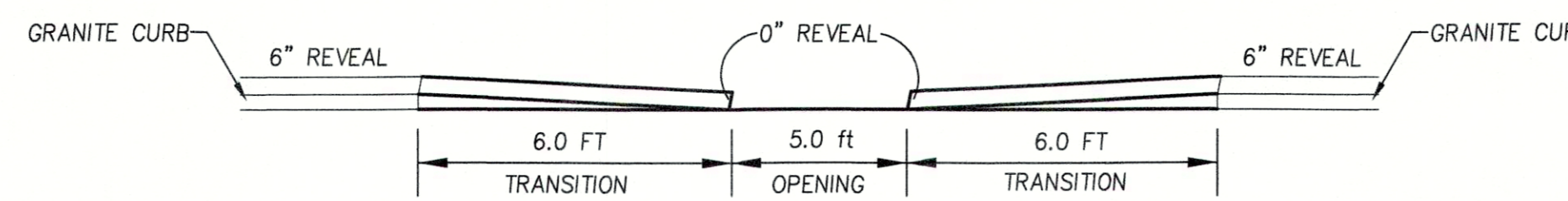

CURB OPENING DETAIL N.T.S.

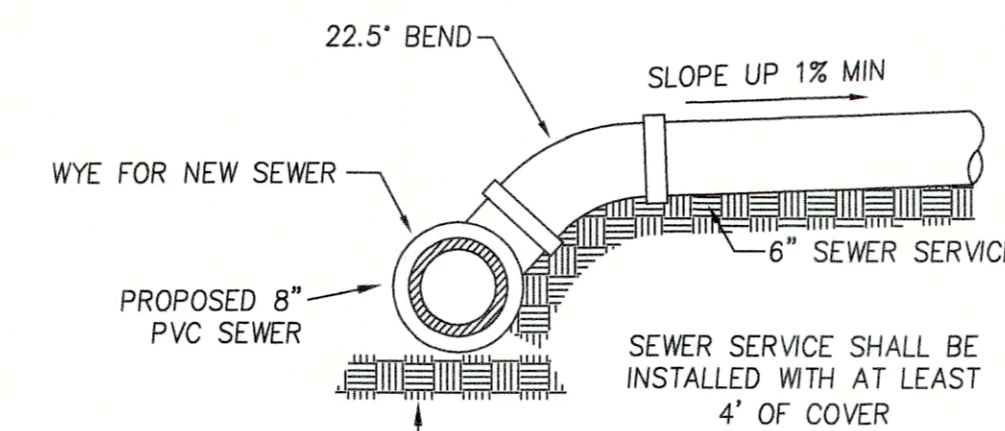

SEWER SERVICE DETAIL N.T.S.

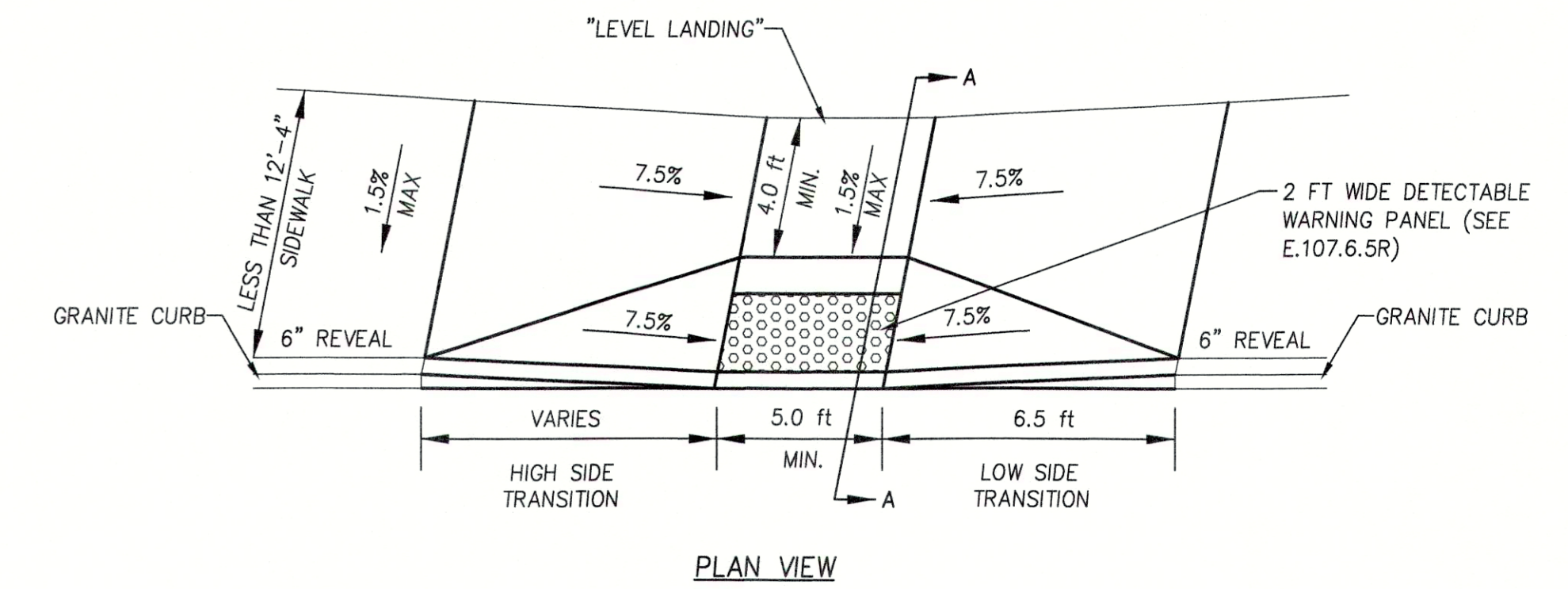

PLAN VIEW

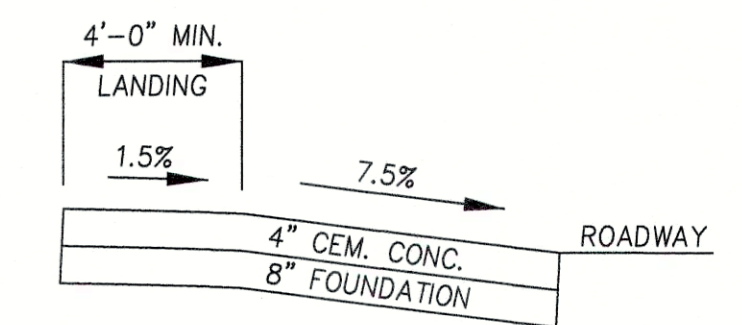

SECTION A-A

NOTES:

- RAMP CROSS SECTION TO BE SAME AS SIDEWALK; I.E. DEPTH OF SURFACE AND FOUNDATION.
- BASE OF RAMP SHALL MEET PAVEMENT GUTTER SUCH THAT THERE IS NO DIFFERENCE IN ELEVATION. RAMP SHALL BE CONSTRUCTED SUCH THAT WATER DOES NOT "PUDDLE" AT THE BASE OF THE RAMP.
- THE PAVEMENT AT THE BASE OF THE RAMP SHALL BE PART OF THE CONTINUOUS TOP COURSE. THE USE OF A "PAVEMENT PATCH" TO COMPLY WITH THE CONDITIONS IN NOTE 2, ABOVE IS PROHIBITED.
- RAMPS SHALL CONFORM TO MASS DOT WHEELCHAIR RAMP STANDARDS - LATEST REVISIONS.

CEMENT CONCRETE WHEELCHAIR RAMP DETAIL N.T.S.

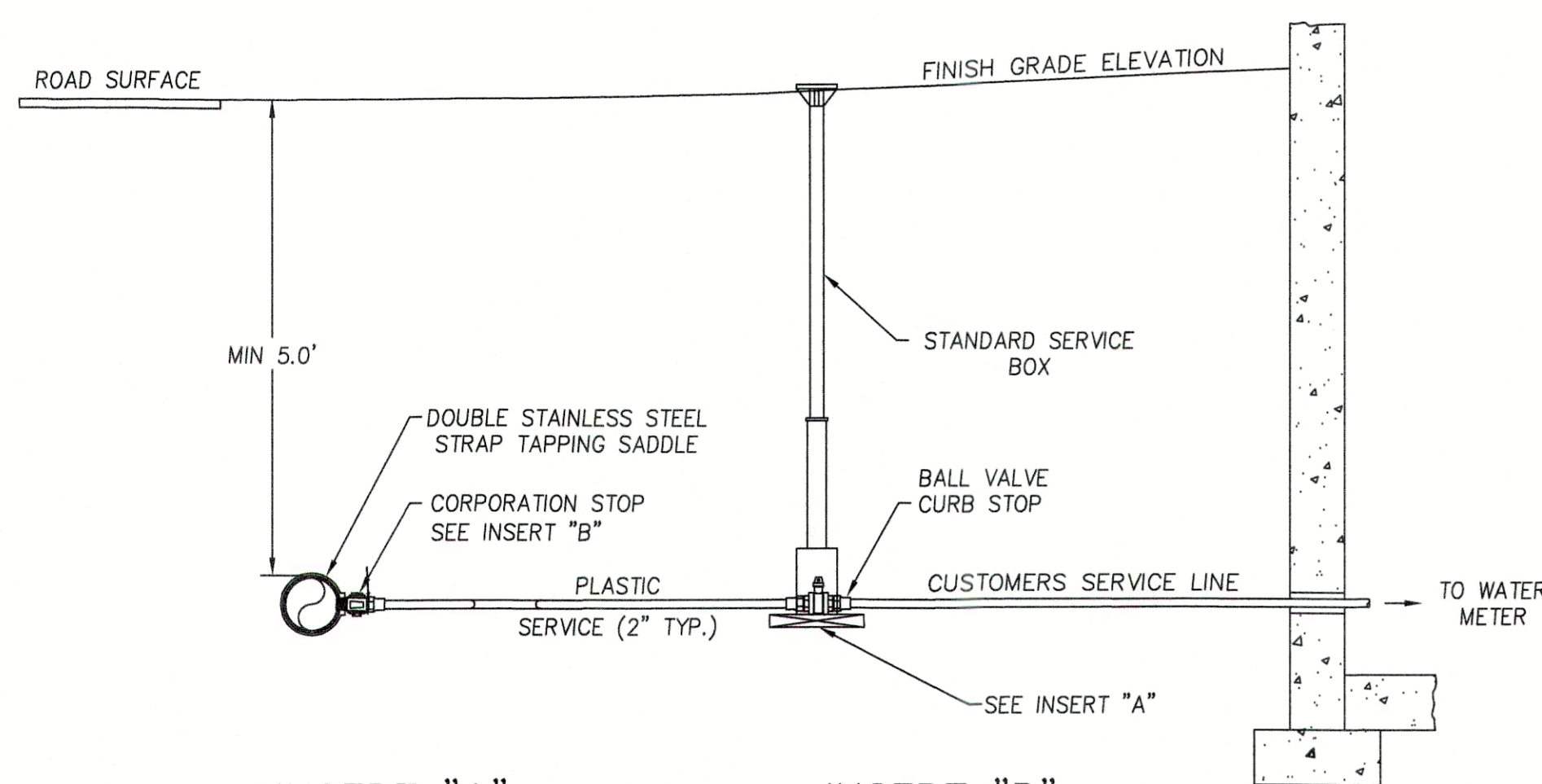

INSERT "A"

INSERT "B"

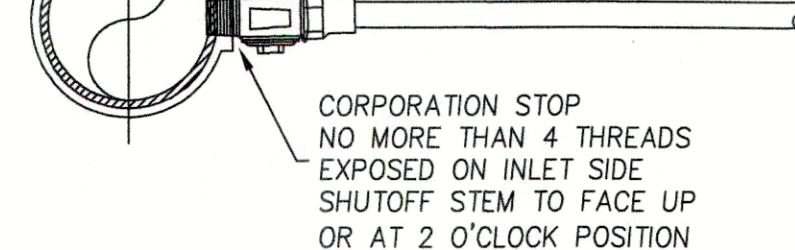
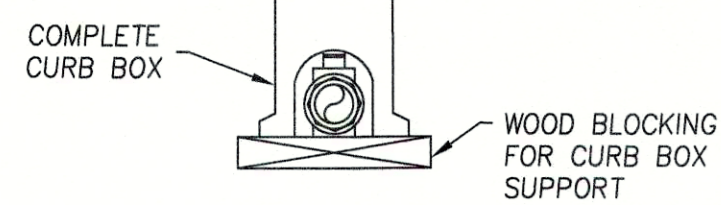

NOTE

- SERVICE CONNECTIONS FOR THE VARIOUS LOTS SHALL BE SIZED TO MEET THE REQUIREMENTS OF THE SPECIFIED USE. CONNECTIONS TO THE PROJECT WATER MAIN SHALL BE MADE WITH TAPPING SLEEVES AND VALVES.

TYPICAL COPPER SERVICE CONNECTION N.T.S.

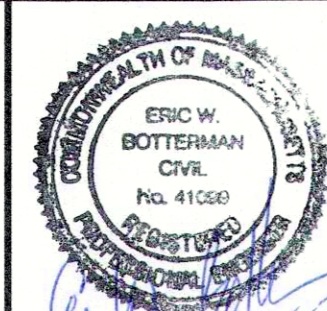

PREPARED FOR
BAVARO FAMILY REALTY TWO, LLC
 18 GRAF ROAD UNIT #31
 NEWBURYPORT, MA

MEI **MILLENNIUM ENGINEERING, INC.**
 ENGINEERING AND LAND SURVEYING
 62 ELM ST. SALISBURY, MA 01952 (978) 463-8980
 13 HAMPTON RD. EXETER, NH 03833 (603) 778-0528

SITE PLAN
 IN
NEWBURY, MA
 SHOWING
PROPOSED SITE IMPROVEMENTS
 AT
3 NEWBURYPORT TURNPIKE

CONSTRUCTION DETAILS
 SHEET: 5 OF 7

NO.	DATE	DESCRIPTION	BY

SCALE: 1"=20'
 DATE: JULY 15, 2020
 DESG. BY: C.M.Y.
 CHKD. BY: E.W.B.
 PROJECT: M193668

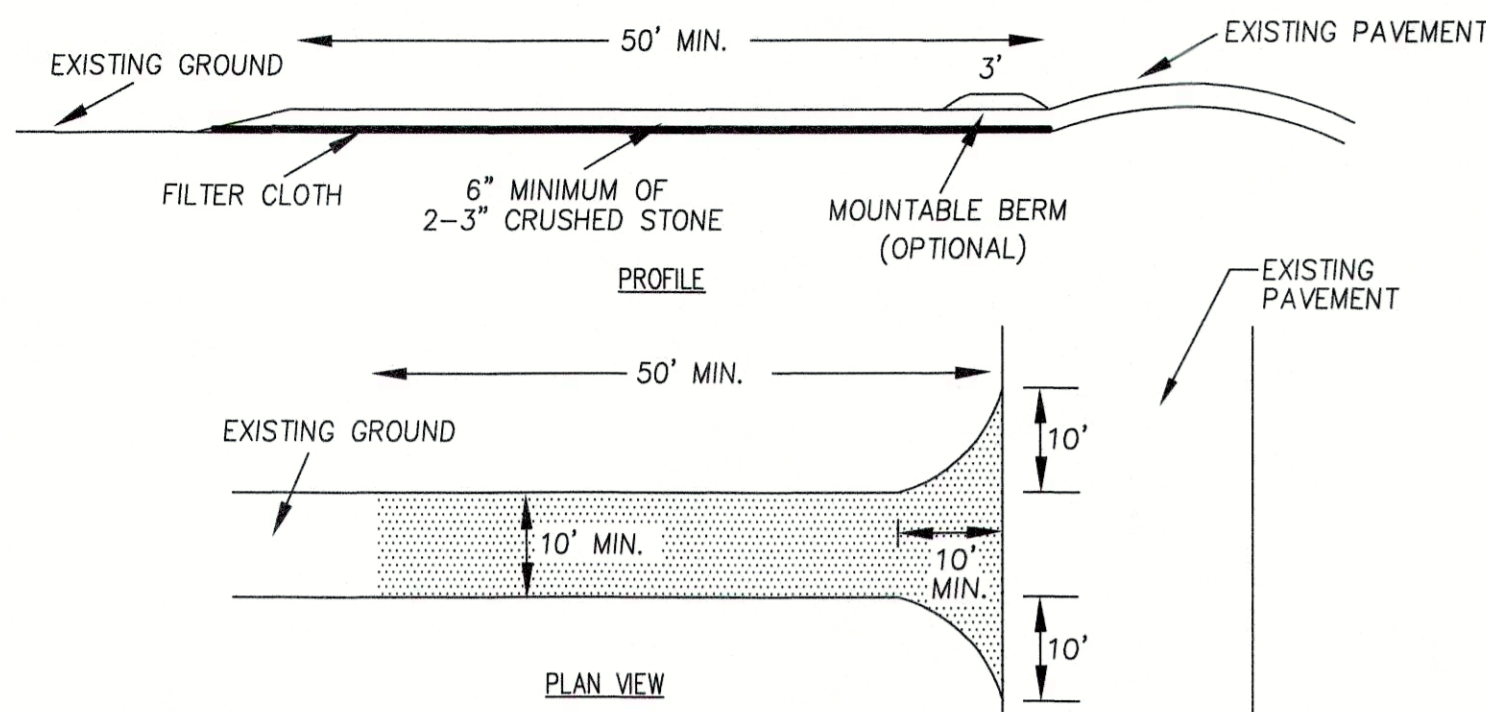

- NOTES**
- STONE SHALL BE 2-3" STONE, RECLAIMED STONE, OR RECYCLED CONCRETE EQUIVALENT.
 - THE LENGTH OF THE STABILIZED ENTRANCE SHALL NOT BE LESS THAN 50'.
 - THE THICKNESS OF THE STONE FOR THE STABILIZED ENTRANCE SHALL NOT BE LESS THAN 6".
 - GEOTEXTILE FILTER CLOTH SHALL BE PLACED OVER THE ENTIRE AREA PRIOR TO PLACING THE STONE.
 - ALL SURFACE WATER THAT IS FLOWING TO OR DIVERTED TOWARD THE CONSTRUCTION ENTRANCE SHALL BE PIPED BENEATH THE ENTRANCE. IF PIPING IS IMPRACTICAL, A BERM WITH 5:1 SLOPES THAT CAN BE CROSSED BY VEHICLES MAY BE SUBSTITUTED FOR THE PIPE.
 - THE ENTRANCE SHALL BE MAINTAINED IN A CONDITION THAT WILL PREVENT TRACKING OR FLOWING OF SEDIMENT ONTO PUBLIC RIGHTS-OF-WAY. THIS MAY REQUIRE PERIODIC TOP-DRESSING WITH ADDITIONAL STONE AS CONDITIONS DEMAND AND REPAIR AND/OR CLEANOUT OF ANY MEASURES USED TO TRAP SEDIMENT. ALL SEDIMENT SPILLED, WASHED, OR TRACKED ONTO PUBLIC RIGHTS-OF-WAY MUST BE REMOVED PROMPTLY.
 - WHEELS SHALL BE CLEANED TO REMOVE MUD PRIOR TO ENTRANCE ONTO PUBLIC RIGHTS-OF-WAY. WHEN WASHING IS REQUIRED, IT SHALL BE DONE ON AN AREA STABILIZED WITH STONE WHICH DRAINS INTO AN APPROVED SEDIMENT TRAPPING DEVICE.

STABILIZED CONSTRUCTION ENTRANCE N.T.S.

GENERAL EROSION CONTROL NOTES

- ALL SILT FENCE SHALL BE INSTALLED BEFORE THE START OF CONSTRUCTION. SILT FENCE SHALL BE REMOVED UPON COMPLETION OF THE PROJECT AND STABILIZATION OF ALL SOIL.
- ALL FILL SHALL BE FREE OF STUMPS AND LARGE STONES. LEDGE ENCOUNTERED ONSITE CAN BE GROUND UP TO A MAXIMUM 3" SIZE AND USED FOR FILL.
- ANY STANDING BODIES OF WATER CREATED DURING EXCAVATION SHALL BE ELIMINATED.
- EROSION CONTROL BARRIERS SHALL BE INSPECTED WEEKLY AND AFTER EVERY 0.5" OF RAINFALL AND PROMPTLY REPAIRED OR REPLACED AS NECESSARY.
- ACCUMULATED SEDIMENT DEPOSITS UPSTREAM OF BARRIERS SHALL BE PROPERLY DISPOSED OF ON A REGULAR BASIS.
- AREAS OUTSIDE THE LIMITS OF WORK (EROSION CONTROL/SILT FENCE LOCATIONS) DISTURBED BY THE CONTRACTOR DURING CONSTRUCTION SHALL BE RESTORED TO THEIR ORIGINAL CONDITION AT THE EXPENSE OF THE CONTRACTOR.
- THE CONTRACTOR IS RESPONSIBLE FOR MAINTAINING EROSION AND/OR SEDIMENT CONTROLS DURING CONSTRUCTION. HE/SHE SHALL INSPECT CONTROLS WEEKLY AND AFTER ALL STORM EVENTS. REPAIRS, IF REQUIRED, SHALL BE MADE IMMEDIATELY.
- TEMPORARY GROUND COVER SHALL BE ESTABLISHED IN AREAS OF CONSTRUCTION WHERE REQUIRED BY THE NEWBURY PLANNING BOARD AND CONSERVATION COMMISSION.
- ANY DISTURBED AREAS OF THE SITE NOT USED FOR ROADWAY OR UTILITY CONSTRUCTION SHALL BE STABILIZED WITH LOAM AND SEED UNTIL FURTHER DISTURBANCE IS REQUIRED FOR BUILDING CONSTRUCTION.
- AN AREA SHALL BE CONSIDERED STABILIZED IF ONE OF THE FOLLOWING HAS OCCURRED: BASE COURSE GRAVELS HAVE BEEN INSTALLED IN AREAS TO BE PAVED; A MINIMUM OF 85% VEGETATED GROWTH HAS BEEN ESTABLISHED; A MINIMUM OF 3" OF NON-EROSIVE MATERIAL SUCH AS STONE OR RIPRAP HAS BEEN INSTALLED; OR EROSION CONTROL BLANKETS HAVE BEEN PROPERLY INSTALLED.
- THE CONTRACTOR SHALL IDENTIFY TO THE TOWN HIS/HER TOPSOIL STOCKPILE OPERATIONS AND LOCATIONS.
- PROVIDE SILTSACK (OR APPROVED EQUAL) SEDIMENT FILTER AT ALL CATCH BASINS.
- A MINIMUM OF 6" OF LOAM SHALL BE INSTALLED ON ALL DISTURBED UNPAVED SURFACES.
- SEED MIX SHALL BE NO LESS THAN 4 LBS./1000 S.F. OF LAND AREA. SEED SHALL CONSIST OF A MAXIMUM OF 10% RYE GRASS AND A MINIMUM OF 90% PERMANENT BLUEGRASS AND/OR FESCUE. LIME SHALL BE APPLIED AT A RATE OF 2 TONS/ACRE.
- NO MORE THAN 6 ACRES SHALL BE DISTURBED AT ONE TIME. ALL AREAS SHALL BE STABILIZED WITHIN 45 DAYS OF INITIAL DISTURBANCE.
- WHERE PLACEMENT OF FILL IS REQUIRED FOR THE CONSTRUCTED WETLAND, FILL SHALL BE PLACED IN AN UNFROZEN STATE UPON UNFROZEN GROUND.

CONSTRUCTION SEQUENCE

- INSTALL SILT FENCE AT LIMIT OF WORK & STAKE OUT INFILTRATION BASIN.
- CONSTRUCT STABILIZED CONSTRUCTION ENTRANCE AS DEPICTED.
- CLEAR AND GRUB DEBRIS TO PHASE LINE AND DISPOSE OF PROPERLY.
- STRIP, SCREEN AND STOCKPILE TOPSOIL. TOPSOIL CAN BE TEMPORARILY STOCKPILED ON SITE PROVIDING THAT THE PERIMETER OF THE STOCKPILES ARE PROPERLY STAKED WITH SILT FENCE AT THE TOE OF SLOPE.
- ROUGH GRADE INFILTRATION BASIN.
- GRADE PAVEMENT TO TOP OF SUBGRADE ELEVATIONS. ALL ROADWAYS MUST BE STABILIZED IMMEDIATELY AFTER GRADING.
- BEGIN BUILDING CONSTRUCTION.
- INSTALL UTILITIES/DRAINAGE STRUCTURES.
- PLACE RIPRAP WHERE SHOWN ON PLANS. LOAM AND HYDROSEED SIDESLOPES AND ALL DISTURBED AREAS WITHIN 72 HOURS.
- SPREAD, SHAPE, AND COMPACT PAVEMENT SUBBASE AS PER TYPICAL PAVEMENT SECTION TO ATTAIN FINAL DESIGN ELEVATIONS.
- PERFORM BINDER COURSE PAVING.
- LOAM AND HYDROSEED ANY DISTURBED SURFACES ALONG EDGES OF PAVEMENT AS REQUIRED.
- PERFORM FINAL PAVING (TOP COURSE).
- REMOVE EROSION CONTROL.

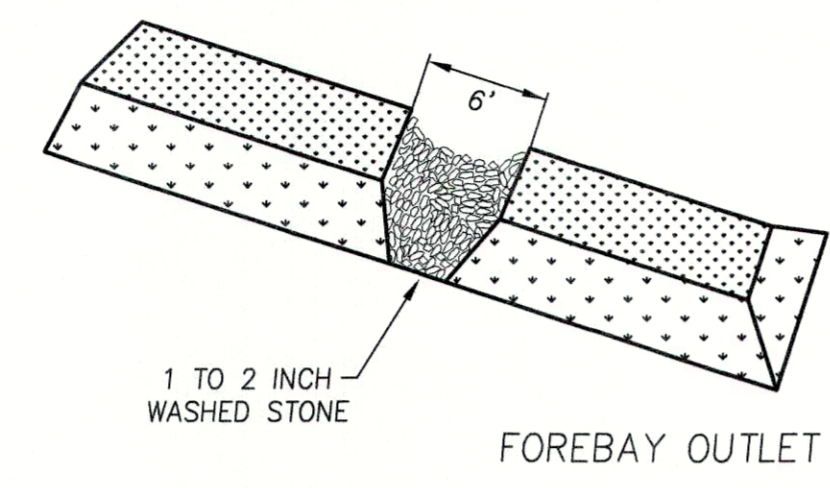

VOLUME OF SEDIMENT FOREBAY

FOREBAY #	DRAINAGE AREA (ACRES)	VOLUME (CU. YD)	VOLUME (CU. FT)	DIMENSIONS (L x W x H)	OUTLET LENGTH
FOREBAY #1	0.24	3.3	89	10'x10'x1.0'	6.0'
FOREBAY #2	0.15	2.0	55	8'x8'x1.0'	6.0'

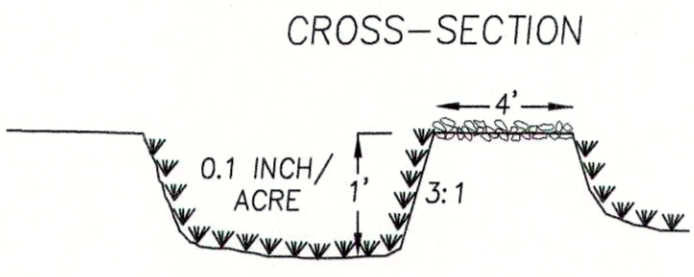

SEDIMENT FOREBAY DETAIL N.T.S.

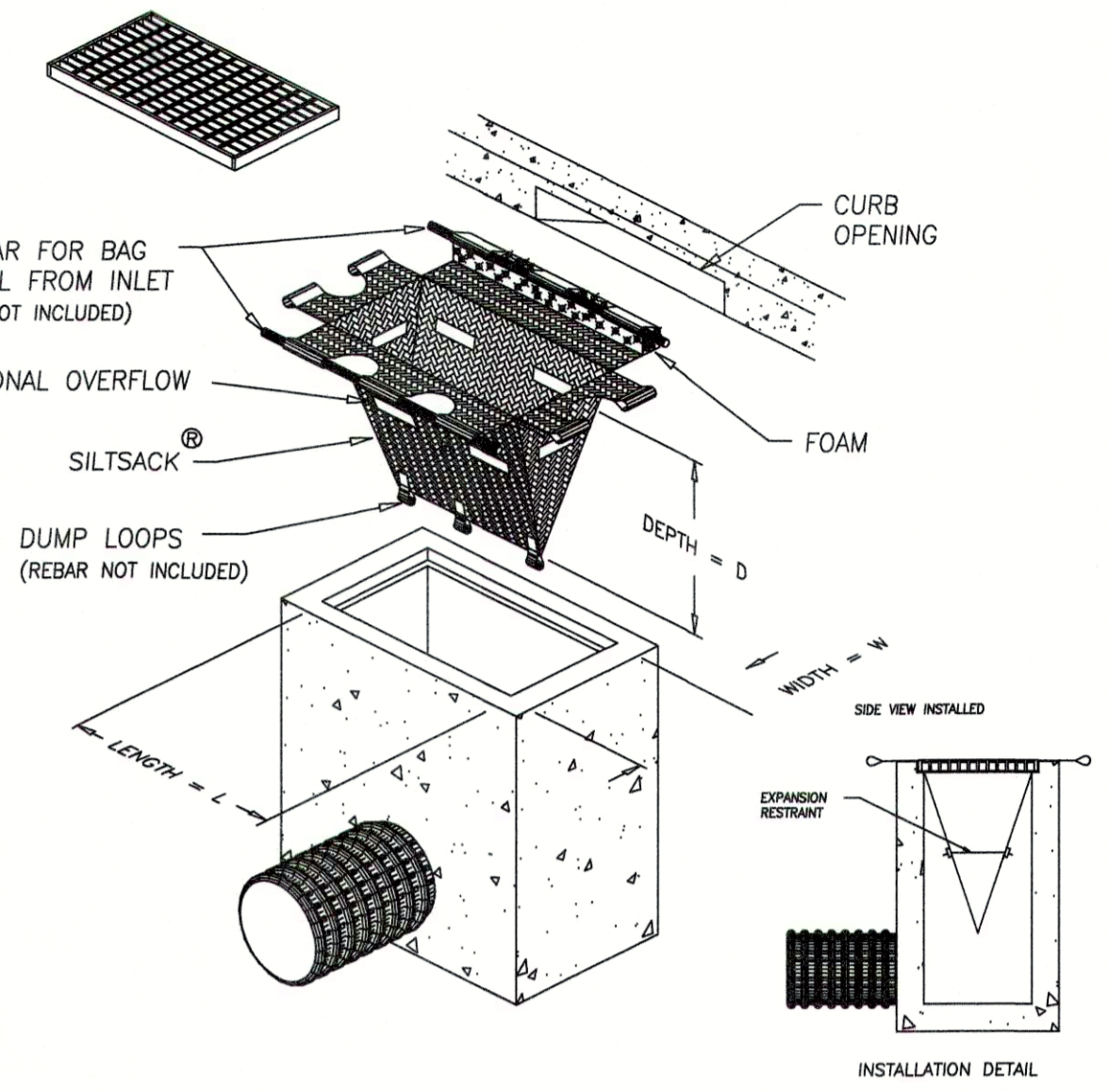
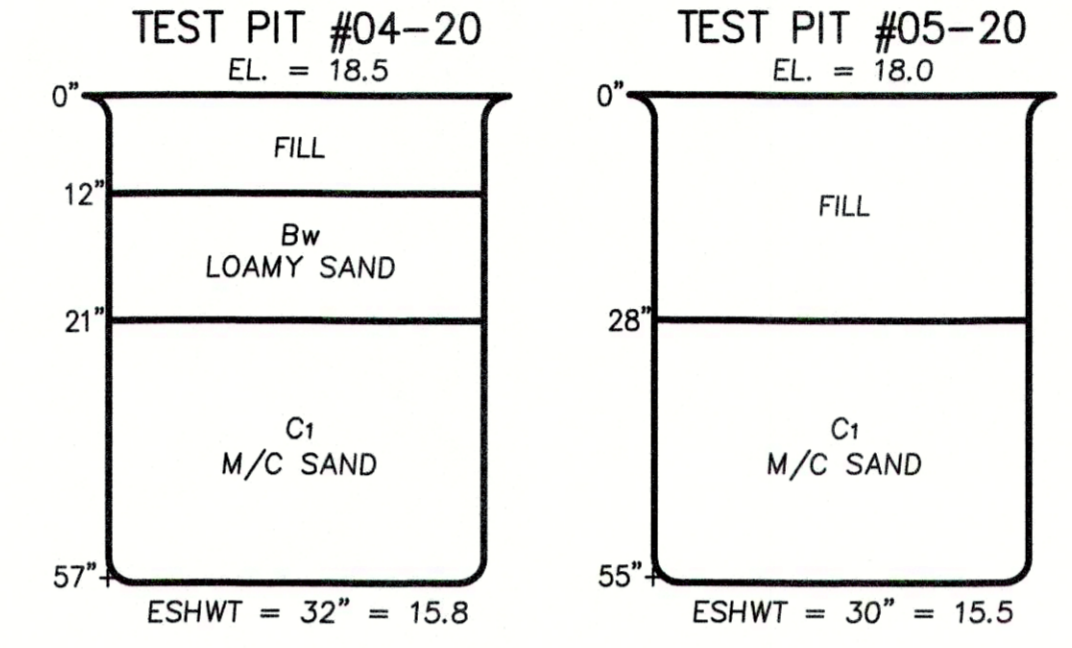
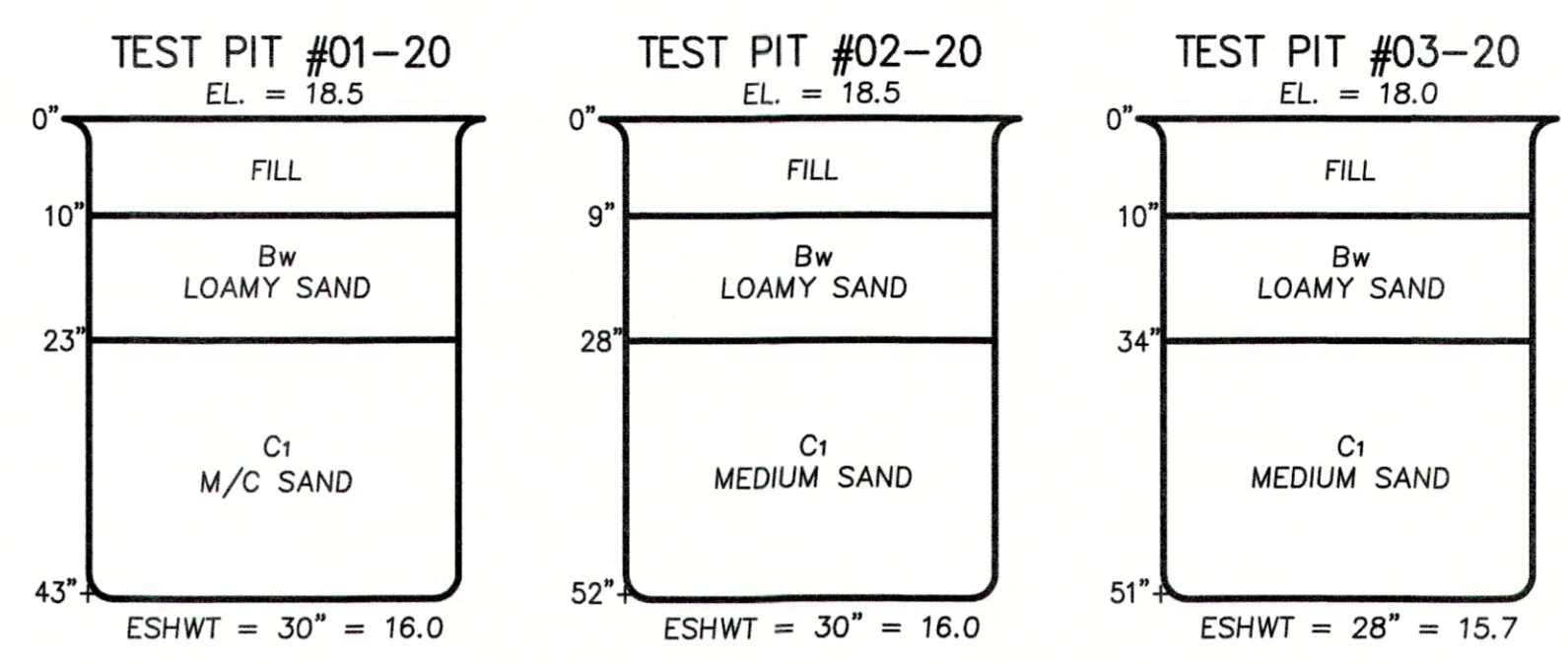

- NOTES**
- TO INSTALL SILTSACK IN THE CATCH BASIN. REMOVE THE GRATE AND PLACE THE SACK IN THE OPENING. HOLD APPROXIMATELY SIX INCHES OF THE SACK OUTSIDE THE FRAME. THIS IS THE AREA OF THE LIFTING STRAPS. REPLACE THE GRATE TO HOLD THE SACK IN PLACE.
 - WHEN THE RESTRAINT CORD IS NO LONGER VISIBLE, SILTSACK IS FULL AND SHOULD BE EMPTIED.
 - TO REMOVE SILTSACK, TAKE TWO PIECES OF 1" DIAMETER REBAR AND PLACE THROUGH THE LIFTING LOOPS ON EACH SIDE OF THE SACK TO FACILITATE THE LIFTING OF SILTSACK.
 - TO EMPTY SILTSACK, PLACE UNIT WHERE THE CONTENTS WILL BE COLLECTED. PLACE THE REBAR THROUGH THE LIFT STRAPS (CONNECTED TO THE BOTTOM OF THE SACK) AND LIFT. THIS WILL LIFT SILTSACK FROM THE BOTTOM AND EMPTY THE CONTENTS. CLEAN OUT AND RINSE. RETURN SILTSACK TO ITS ORIGINAL SHAPE AND PLACE BACK IN THE BASIN.
 - SILTSACK IS REUSABLE. ONCE THE CONSTRUCTION CYCLE IS COMPLETE, REMOVE SILTSACK FROM THE BASIN AND CLEAN. SILTSACK SHOULD BE STORED OUT OF SUNLIGHT UNTIL NEXT USE.

SILT SACK DETAIL N.T.S.

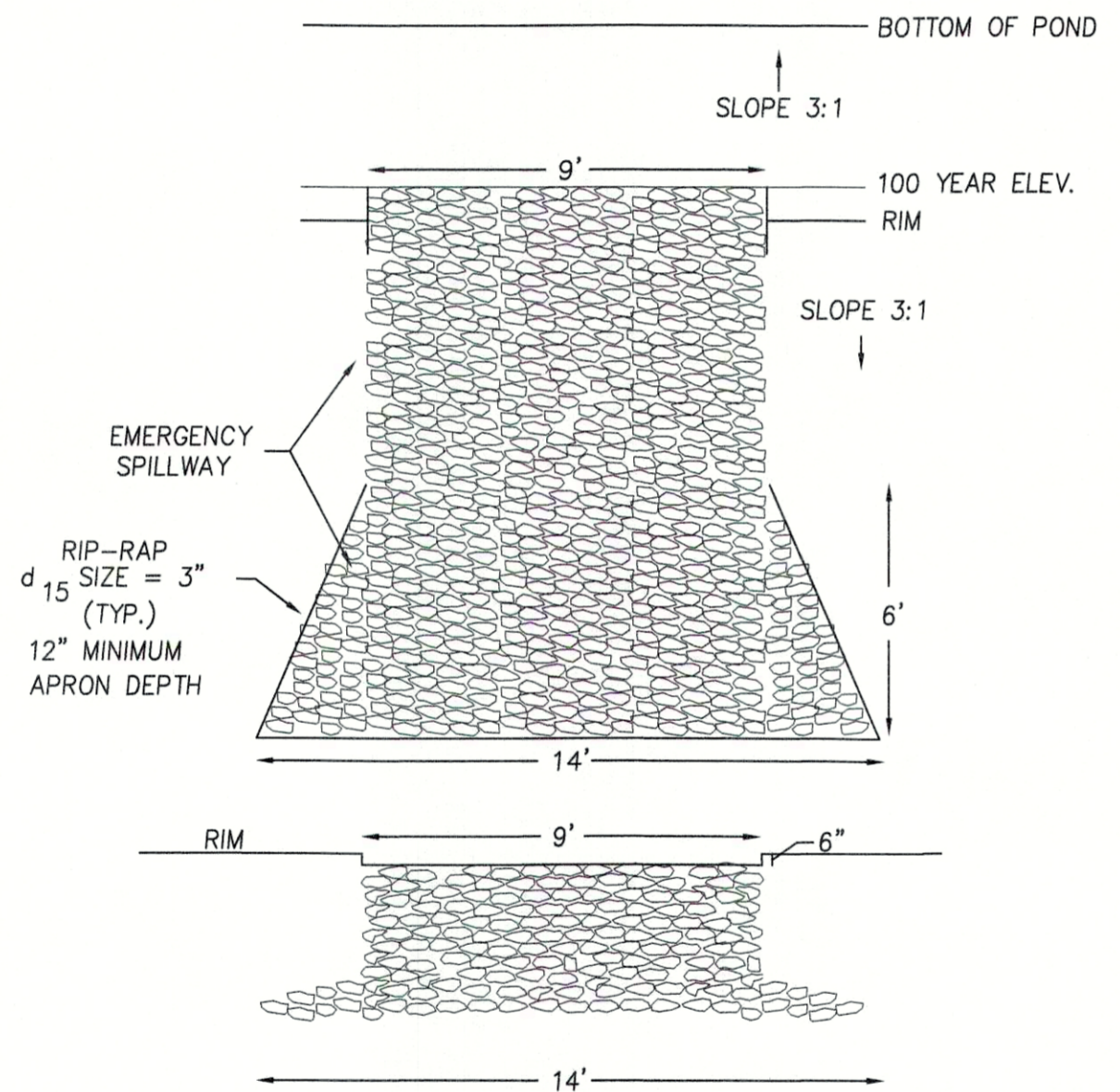

TYPICAL SPILLWAY PLAN VIEW N.T.S.

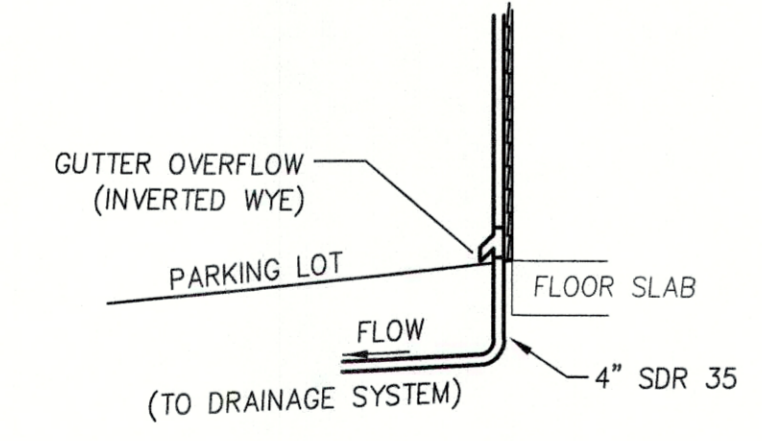

GUTTER DOWN SPOUT DETAIL N.T.S.

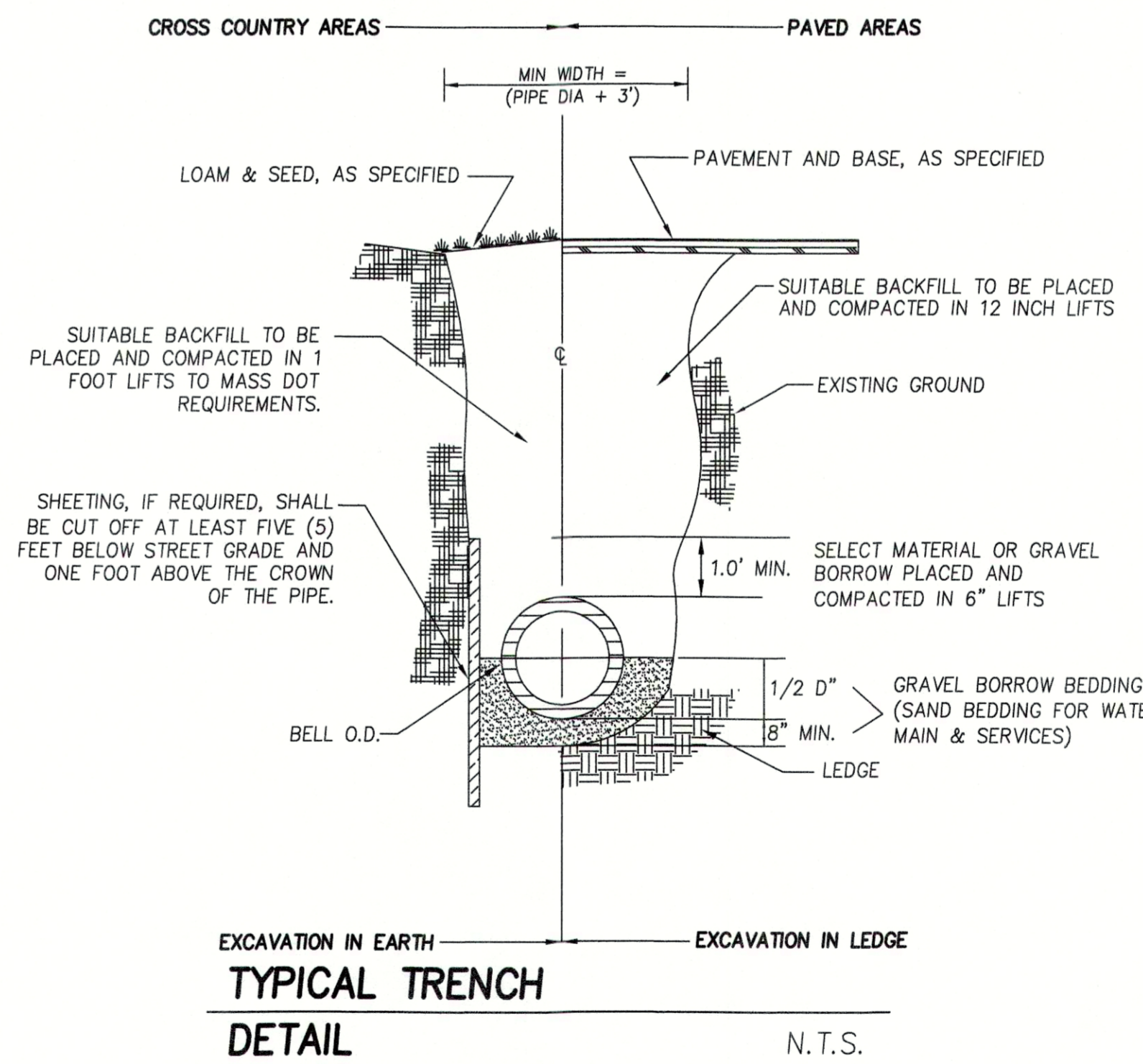

TYPICAL TRENCH DETAIL N.T.S.

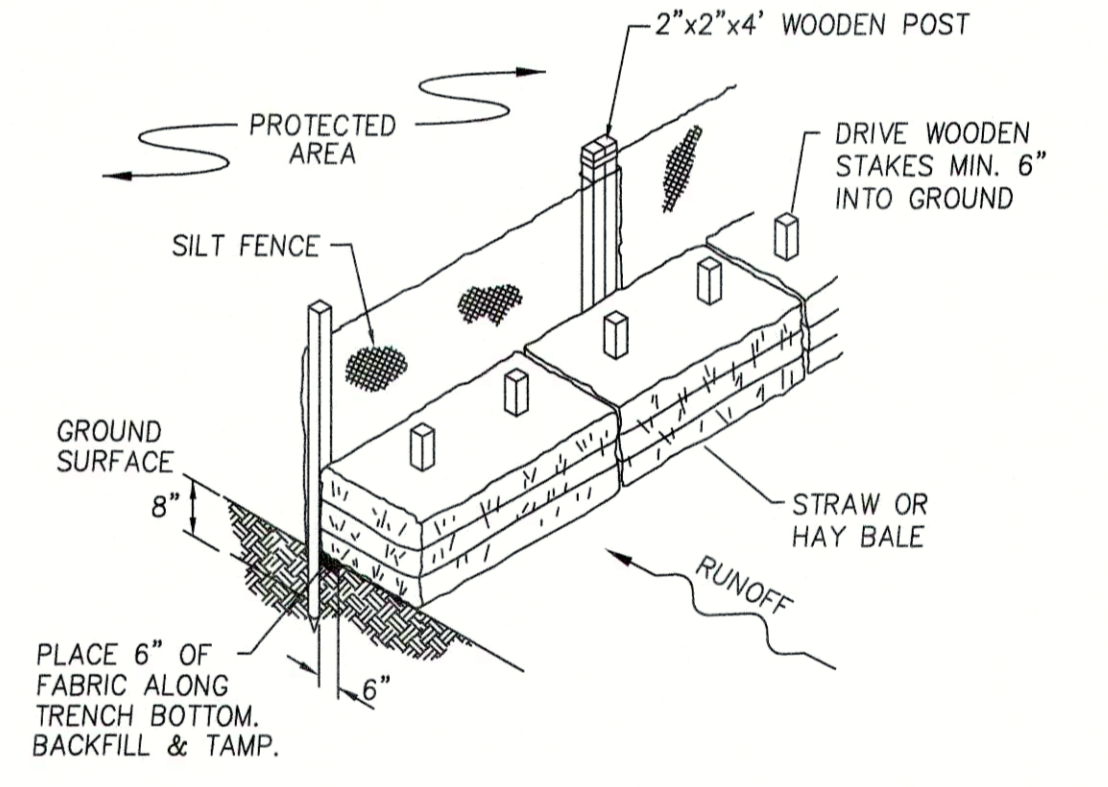

- NOTES**
- POSTS SHALL BE DOUBLED AND COUPLED AT FILTER CLOTH SEAMS.
 - FILTER CLOTH TO BE FASTENED SECURELY TO SUPPORT NETTING WITH TIES SPACED EVERY 24" AT TOP, MID SECTION, AND BOTTOM.
 - WHEN TWO SECTIONS OF FILTER CLOTH ADJOIN EACH OTHER, THEY SHALL BE OVERLAPPED BY 6 INCHES, FOLDED AND STAPLED.
- MAINTENANCE**
- SILT FENCE SHALL BE INSPECTED IMMEDIATELY AFTER EACH RAINFALL AND AT LEAST DAILY DURING PROLONGED RAINFALL. ANY REPAIRS THAT ARE REQUIRED SHALL BE MADE IMMEDIATELY.
 - IF THE FABRIC ON THE SILT FENCE SHALL DECOMPOSE OR BECOME INEFFECTIVE DURING THE EXPECTED LIFE OF THE FENCE, THE FABRIC SHALL BE REPLACED PROMPTLY.
 - SEDIMENT DEPOSITS SHALL BE INSPECTED AFTER EVERY STORM EVENT. THE DEPOSITS SHALL BE REMOVED WHEN THEY REACH APPROXIMATELY ONE-THIRD THE HEIGHT OF THE BARRIER.
 - SEDIMENT DEPOSITS THAT ARE REMOVED OR LEFT IN PLACE AFTER THE FABRIC HAS BEEN REMOVED SHALL BE GRADED TO CONFORM WITH THE EXISTING TOPOGRAPHY AND VEGETATED.

SILT FENCE/HAYBALE INSTALLATION N.T.S.

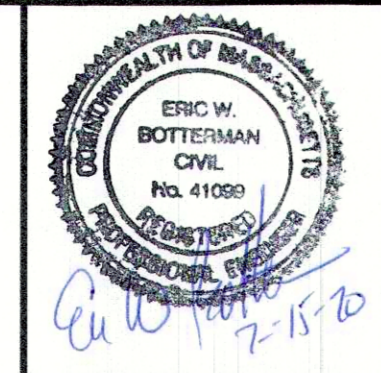

PREPARED FOR
BAVARO FAMILY REALTY TWO, LLC
18 GRAF ROAD UNIT #31
NEWBURYPORT, MA

MILLENNIUM ENGINEERING, INC.
ENGINEERING AND LAND SURVEYING
62 ELM ST. SALISBURY, MA 01952 (978) 463-8980
13 HAMPTON RD. EXETER, NH 03833 (603) 778-0528

PLAN OF LAND
IN
NEWBURY, MA
SHOWING
PROPOSED SITE IMPROVEMENTS
AT
3 NEWBURYPORT TURNPIKE

CONSTRUCTION DETAILS
SHEET: 6 OF 7

NO.	DATE	DESCRIPTION	BY

SCALE: 1"=20' DESG. BY: C.M.Y. PROJECT: M193668
DATE: JULY 15, 2020 CHKD. BY: E.W.B.

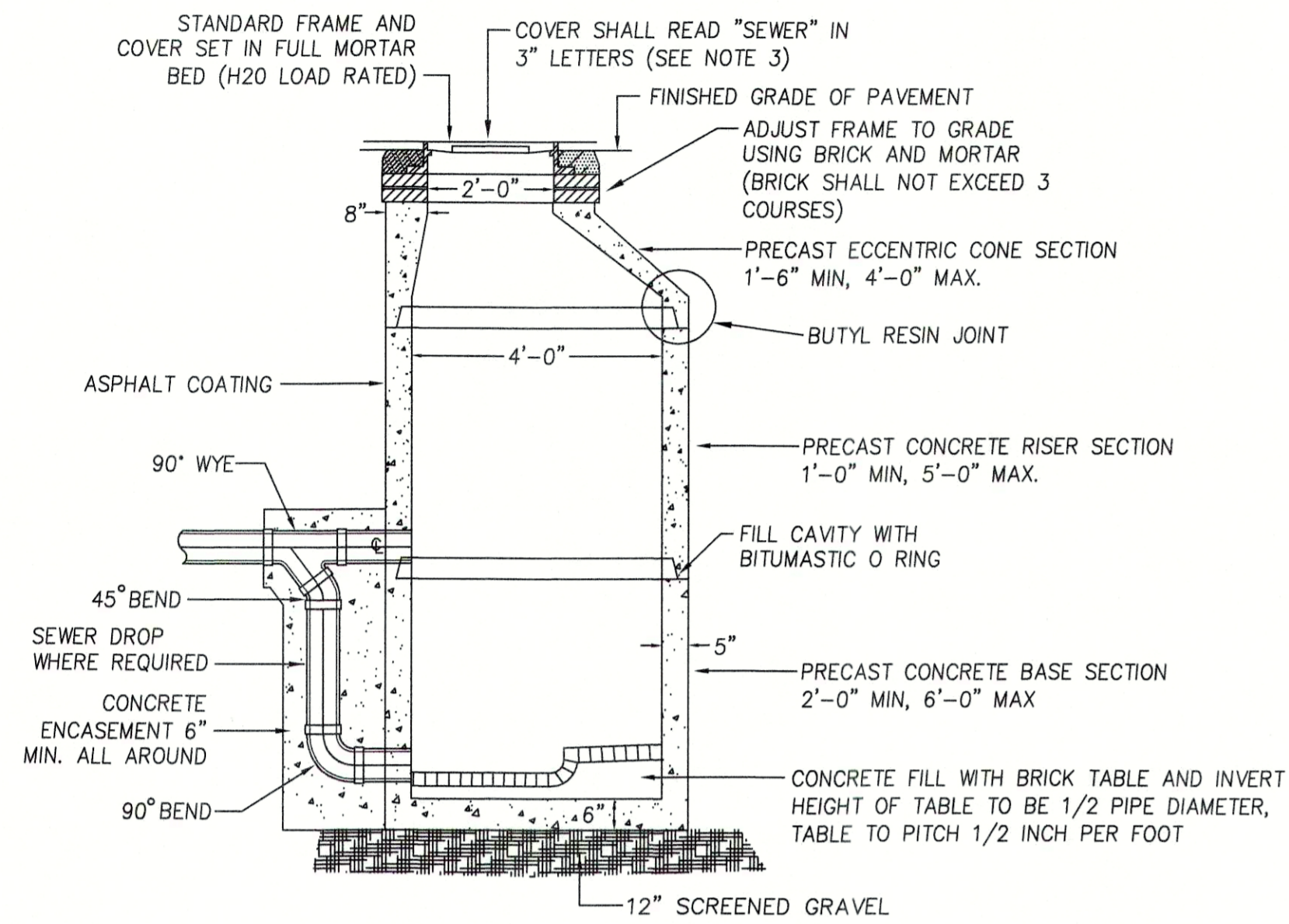

- NOTES: 1) SEWER MANHOLES SHALL CONFORM TO ASTM C478 AND ASTM C185
 2) COVER SHALL BE LEBARON FOUNDRY (MODEL NO. LA246), MECHANICS IRON FOUNDRY, NEEHAN FOUNDRY, OR EQUAL.

**PRECAST SEWER
 MANHOLE DETAIL**

N.T.S.

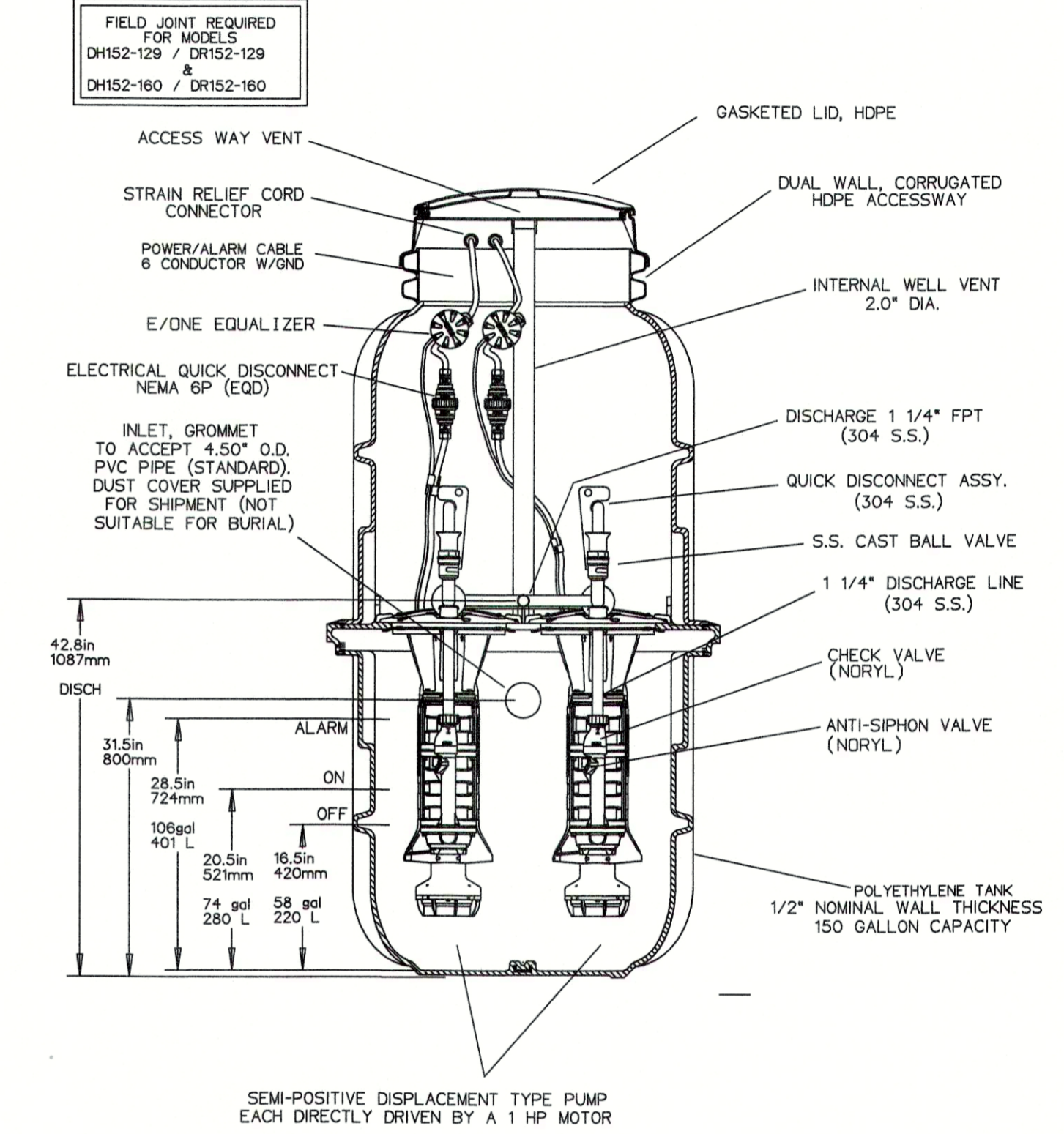
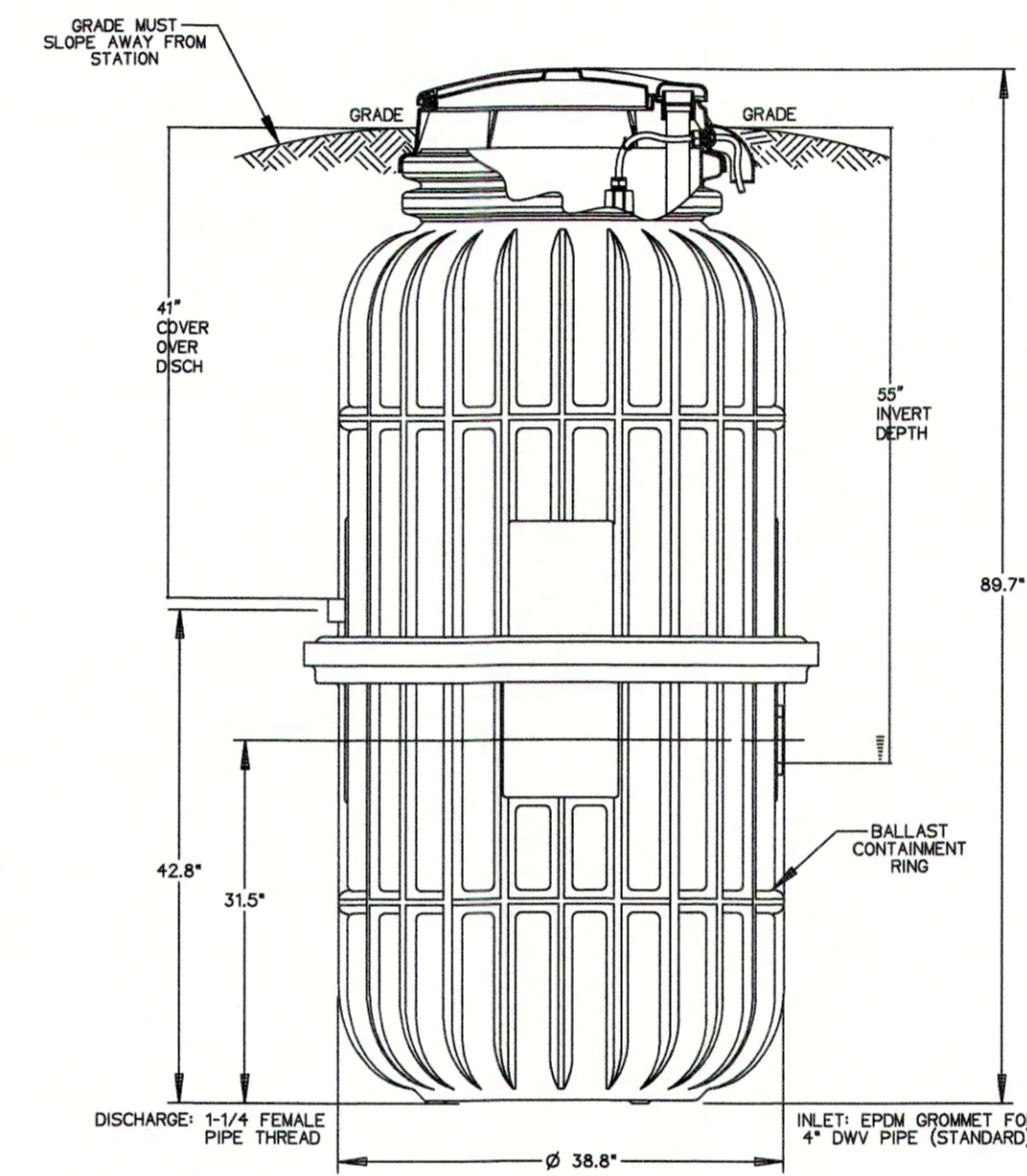

CONCRETE BALLAST MAY BE REQUIRED
 SEE INSTALLATION INSTRUCTIONS
 FOR DETAILS

NOTE: DIMENSIONS ARE FOR REF ONLY

**E-ONE SEWER PUMP
 MODEL DH152 DETAIL**

N.T.S.

	PREPARED FOR BAVARO FAMILY REALTY TWO, LLC 18 GRAF ROAD UNIT #31 NEWBURYPORT, MA		SITE PLAN IN NEWBURY, MA SHOWING PROPOSED SITE IMPROVEMENTS AT 3 NEWBURYPORT TURNPIKE		CONSTRUCTION DETAILS SHEET: 7 OF 7
	SCALE: 1"=20' DATE: JULY 15, 2020		DESG. BY: C.M.Y. CHKD. BY: E.W.B.	PROJECT: M193668	
NO. DATE DESCRIPTION BY					

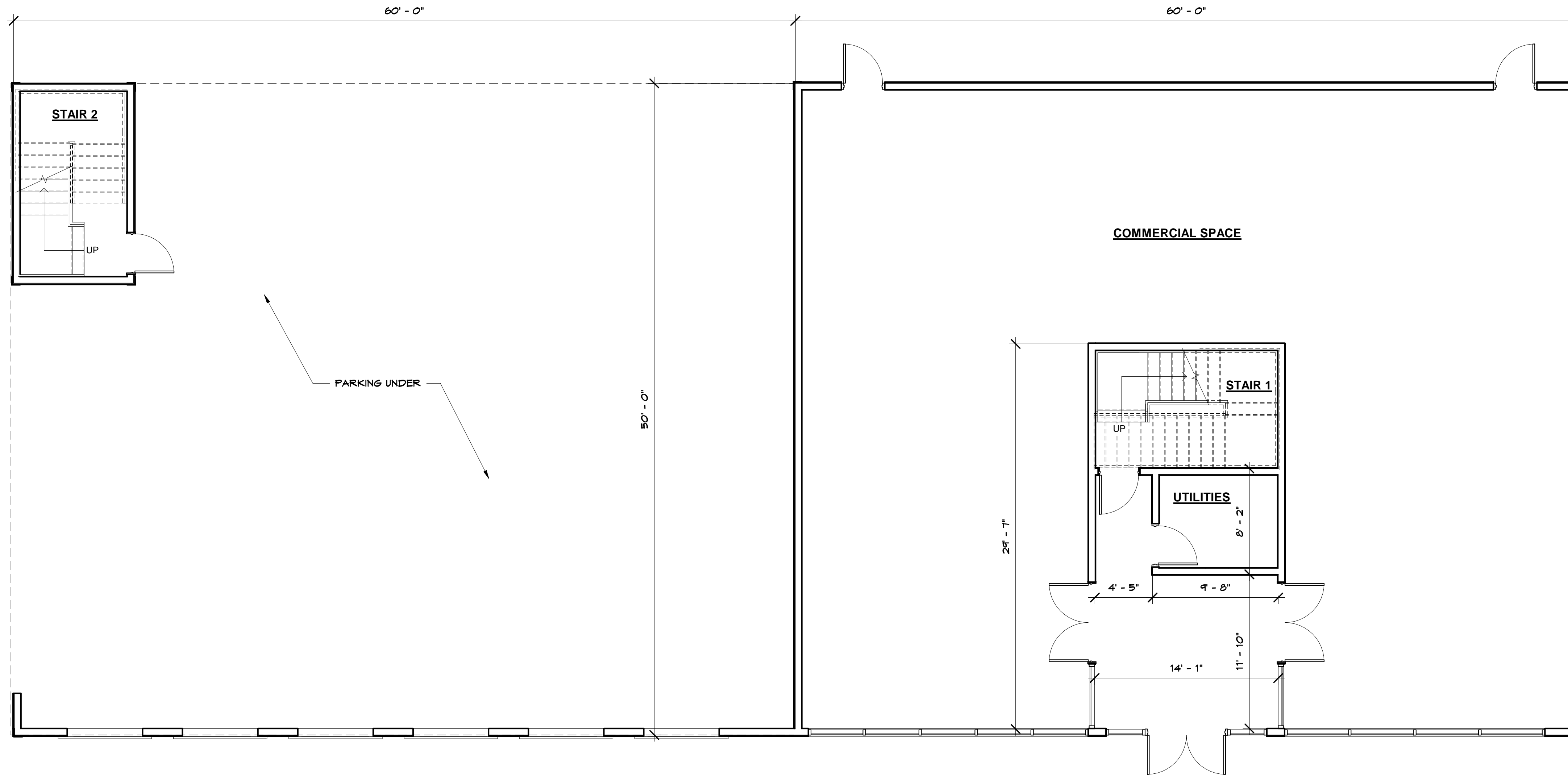

① GROUND FLOOR PLAN
3/16" = 1'-0"

A

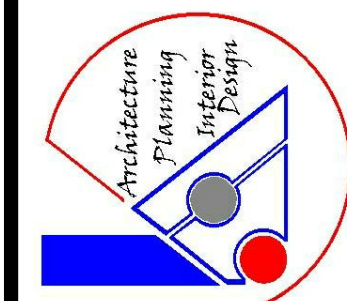

KRITIKOS ARCHITECTS

14 Olsen Road Peabody, MA 01960 (978) 531-4164
E-Mail: phil@kritikosarchitects.com
www.kritikosarchitects.com

JOB TITLE #: NEW MIXED USE BUILDING
NEWBURYPORT, MA 01961

CLIENT NAME #: MR. JOE BAVARO
16 GRAF ROAD UNIT 31
NEWBURYPORT, MA 01960

DATE: 8-3-2020

SCALE: AS NOTED
DRAWN BY: PAK

DRAWING TITLE: GROUND FLOOR PLAN

STAMP:

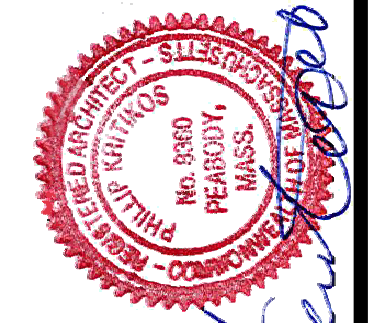

A-1



STAMP:

DRAWING TITLE: SECOND FLOOR PLAN

DATE: 8-3-2020

SCALE: AS NOTED

JOB TITLE #: NEW MIXED USE BUILDING
NEWBURYPORT, MA 01960

KRITIKOS ARCHITECTS

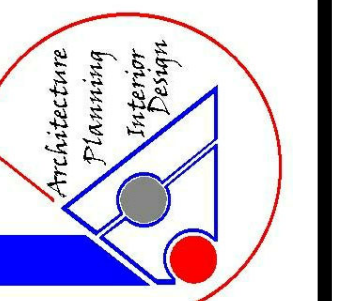

A-2

REVISIONS:

DRAWN BY: Author

CLIENT NAME #: MR. JOE BAVARO
15 GRAF ROAD UNIT 31
NEWBURYPORT, MA 01960

14 Olsen Road Peabody, MA 01960 (978) 531-4164
E-Mail: phil@kritikosarchitects.com
www.kritikosarchitects.com

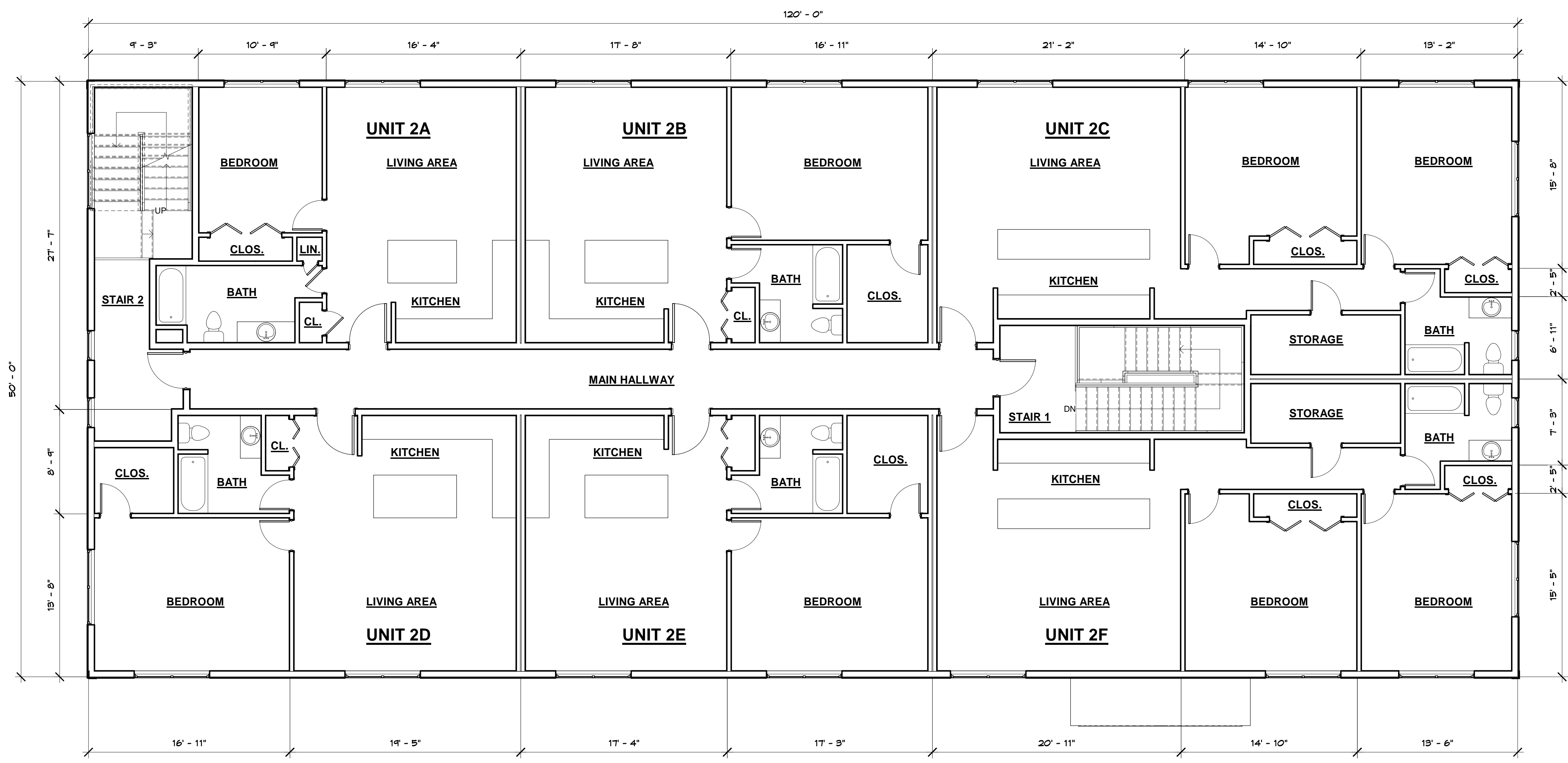

1 SECOND FLOOR PLAN
3/16" = 1'-0"

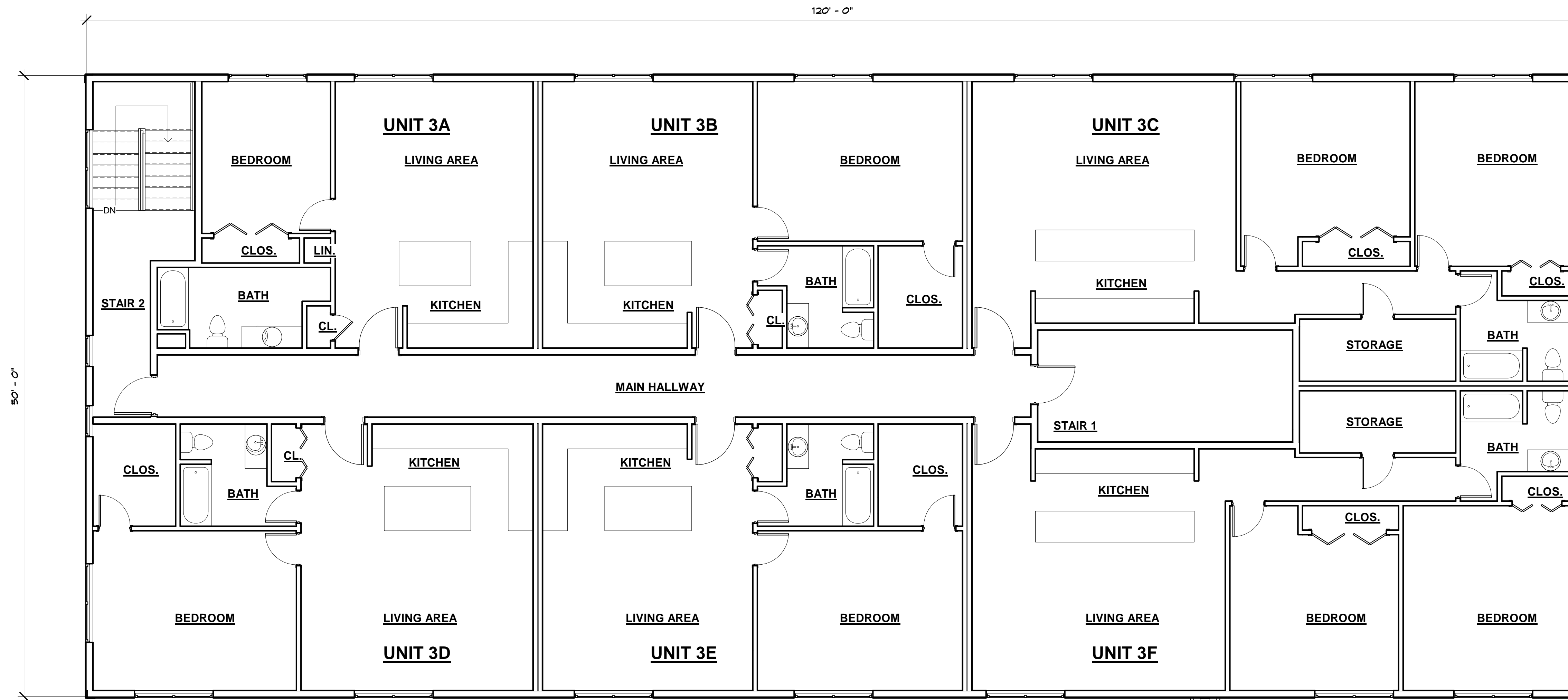

① THIRD FLOOR PLAN
3/16" = 1'-0"



STAMP:

DRAWING TITLE: THIRD FLOOR PLAN

DATE: 8-3-2020

SCALE: AS NOTED

REVISIONS:

DRAWN BY: Author

Author

JOB TITLE #: NEW MIXED USE BUILDING
NEWBURYPORT, MA 01961

CLIENT NAME #: MR. JOE BAVARO
18 GRAF ROAD UNIT 31
NEWBURYPORT, MA 01960

KRITIKOS ARCHITECTS

14 Olsen Road Peabody, MA 01960 (978) 531-4164
E-Mail: phil@kritikosarchitects.com
www.kritikosarchitects.com

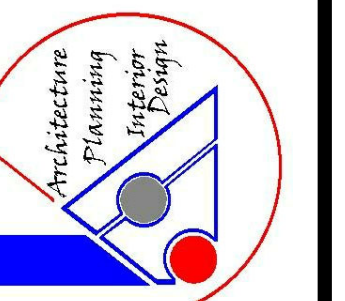

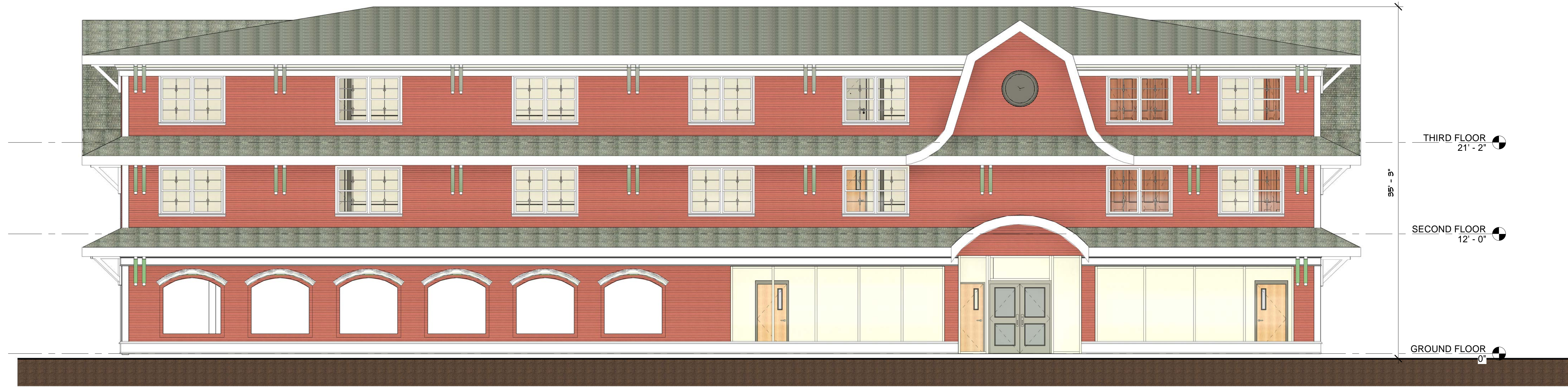

① FRONT ELEVATION
3/16" = 1'-0"



② RIGHT ELEVATION
3/16" = 1'-0"



STAMP:

DRAWING TITLE ELEVATIONS

DATE: 9-3-2020

SCALE: AS NOTED

DRAWN BY: Author

REVISIONS:

JOB TITLE #: NEW MIXED USE BUILDING
NEWBURYPORT, DUNNPIKE
NEWBURYPORT, MA 01951

CLIENT NAME #: MR. JOE BAVARO
16 GRAF ROAD UNIT 31
NEWBURYPORT, MA 01950

KRITIKOS ARCHITECTS

14 Olsen Road Peabody, MA 01960 (978) 531-4164

E-Mail: phil@kritikosarchitects.com

www.kritikosarchitects.com

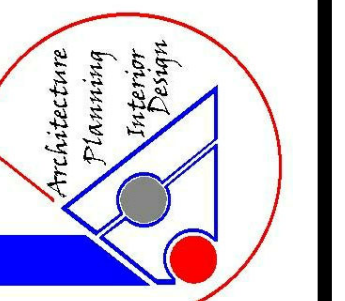



① REAR ELEVATION
3/16" = 1'-0"



② LEFT ELEVATION
3/16" = 1'-0"

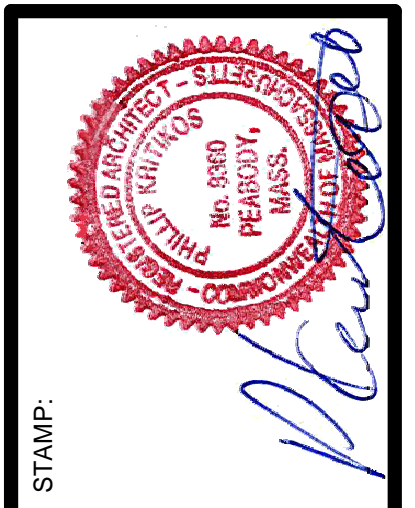
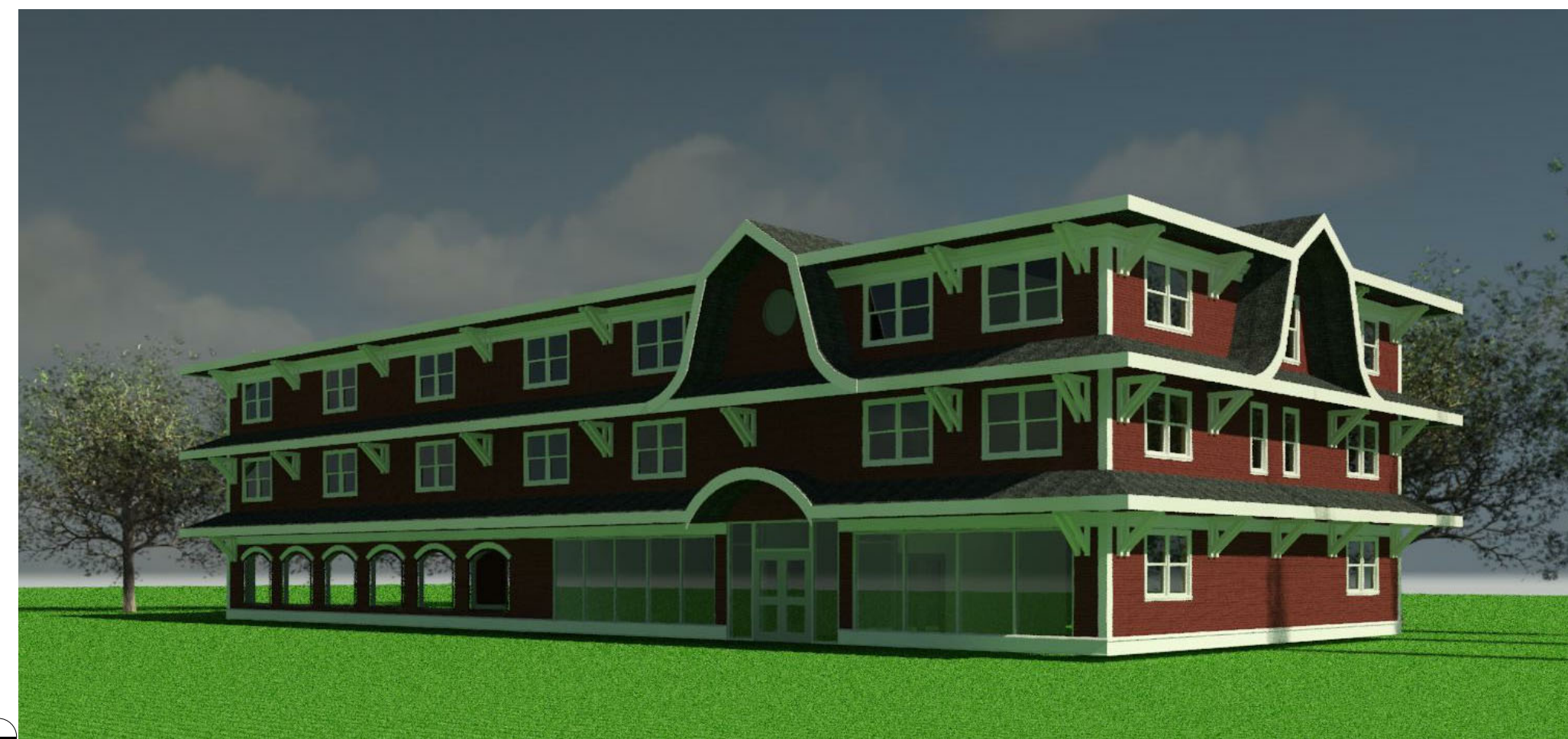

STAMP:

DRAWING TITLE ELEVATIONS

DATE: 9-3-2020

SCALE: AS NOTED

DRAWN BY: Author

JOB TITLE #: NEW MIXED USE BUILDING
NEWBURYPORT DUNNPIKE
NEWBURY, MA 01901

CLIENT NAME #: MR. JOE BAVARO
16 GRAF ROAD UNIT 31
NEWBURYPORT, MA 01950

KRITIKOS ARCHITECTS

14 Olsen Road Peabody, MA 01960 (978) 531-4164
E-Mail: phil@kritikosarchitects.com
www.kritikosarchitects.com

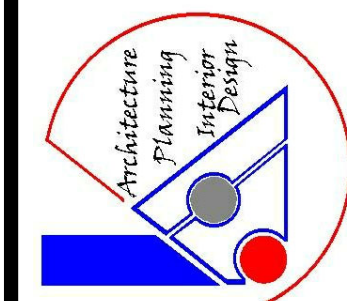

A-5

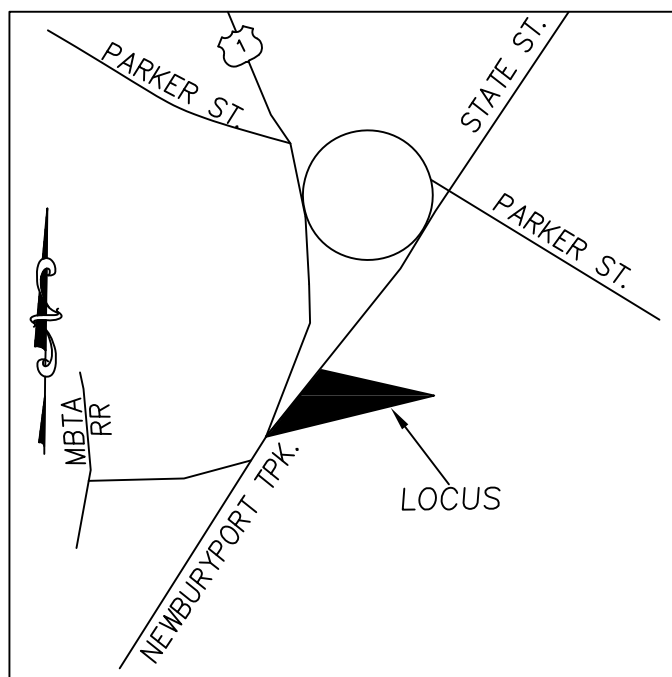

LOCUS MAP
N.T.S.

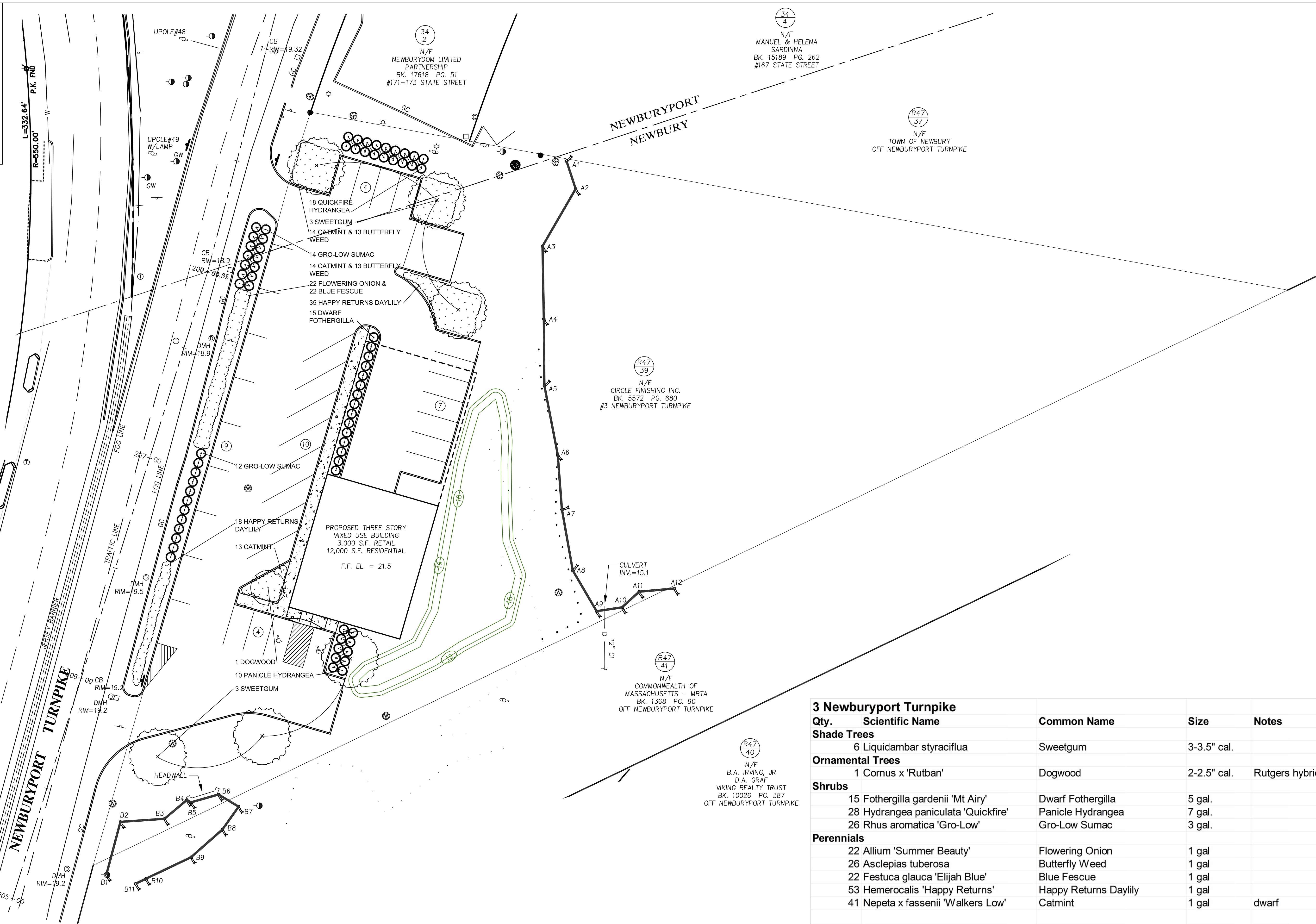

Qty.	Scientific Name	Common Name	Size	Notes
3 Newburyport Turnpike				
Shade Trees				
6	Liquidambar styraciflua	Sweetgum	3-3.5" cal.	
Ornamental Trees				
1	Cornus x 'Rutban'	Dogwood	2-2.5" cal.	Rutgers hybrid
Shrubs				
15	Fothergilla gardenii 'Mt Airy'	Dwarf Fothergilla	5 gal.	
28	Hydrangea paniculata 'Quickfire'	Panicle Hydrangea	7 gal.	
26	Rhus aromatica 'Gro-Low'	Gro-Low Sumac	3 gal.	
Perennials				
22	Allium 'Summer Beauty'	Flowering Onion	1 gal	
26	Asclepias tuberosa	Butterfly Weed	1 gal	
22	Festuca glauca 'Elijah Blue'	Blue Fescue	1 gal	
53	Hemerocallis 'Happy Returns'	Happy Returns Daylily	1 gal	
41	Nepeta x fassenii 'Walkers Low'	Catmint	1 gal	dwarf

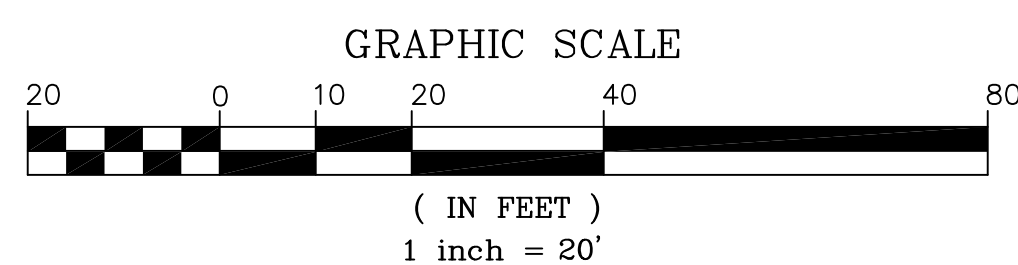

PREPARED FOR
BROTHERS ELECTRIC
3 NEWBURYPORT TURNPIKE
NEWBURY, MA

KD Turner Design
landscape architecture
27 High St.
Newburyport, MA 01950
ph) 781.632.6004

PLAN OF LAND
IN
NEWBURY, MA
SHOWING
PROPOSED SITE IMPROVEMENTS
AT
3 NEWBURYPORT TURNPIKE

LANDSCAPE PLAN

NO.	DATE	DESCRIPTION	BY
1	6-17-20	FOR REVIEW	KT

SCALE: 1"=20'
DATE: JUN. 17, 2020



Site Lighting Layout
At
3 NEWBURYPORT TURNPIKE

Designer
Heidi G. Connors
Visible Light, Inc.
24 Stickney Terrace
Suite 6
Hampton, NH 03842

Date
6/24/2020

Scale
1"=20'

Drawing No.

Summary

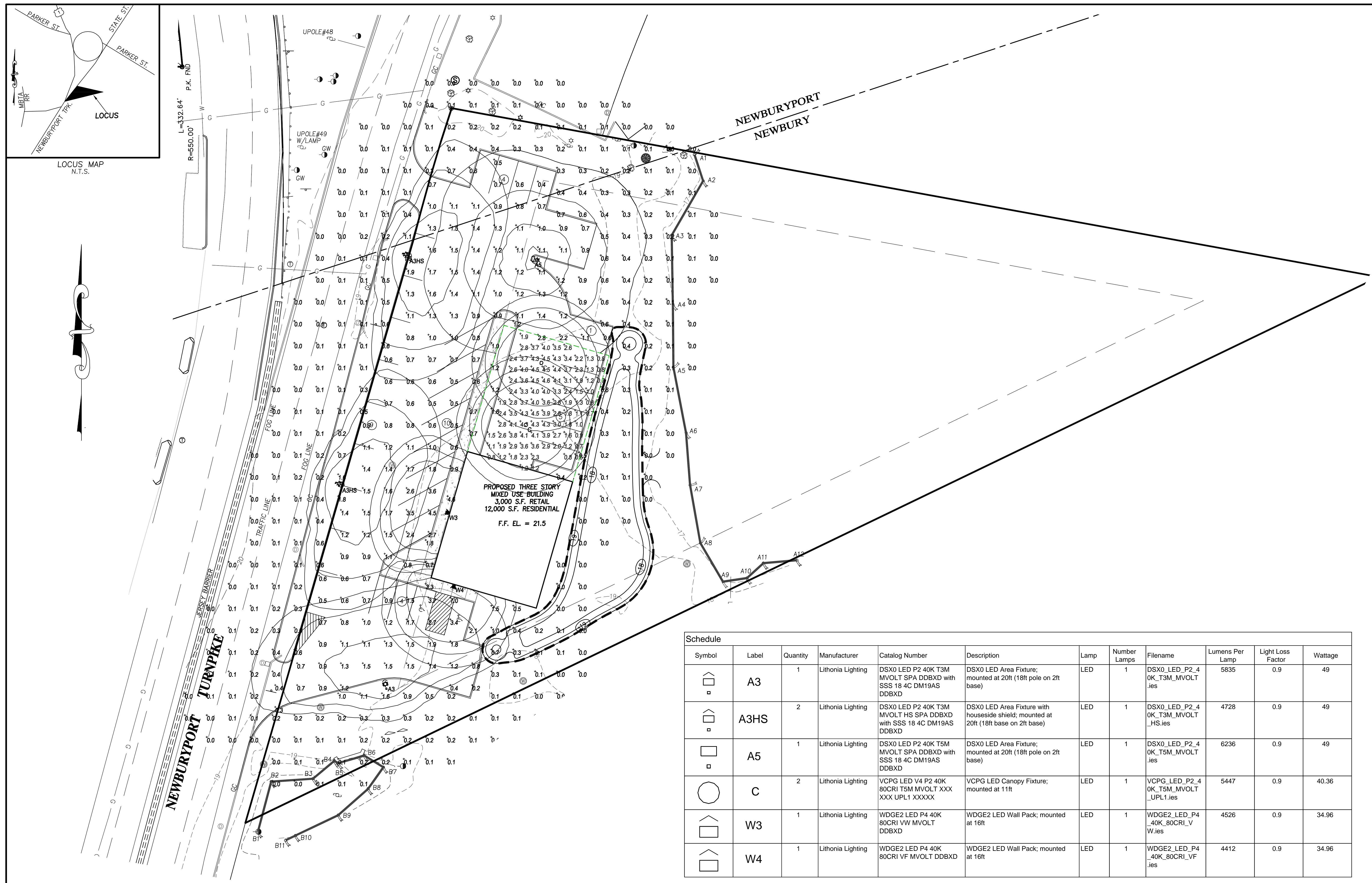

Schedule											
Symbol	Label	Quantity	Manufacturer	Catalog Number	Description	Lamp	Number Lamps	Filename	Lumens Per Lamp	Light Loss Factor	Wattage
	A3	1	Lithonia Lighting	DSX0 LED P2 40K T3M MVOLT SPA DDBXD with SSS 18 4C DM19AS DDBXD	DSX0 LED Area Fixture; mounted at 20ft (18ft pole on 2ft base)	LED	1	DSX0_LED_P2_40K_T3M_MVOLT_ies	5835	0.9	49
	A3HS	2	Lithonia Lighting	DSX0 LED P2 40K T3M MVOLT HS SPA DDBXD with SSS 18 4C DM19AS DDBXD	DSX0 LED Area Fixture with houseside shield; mounted at 20ft (18ft base on 2ft base)	LED	1	DSX0_LED_P2_40K_T3M_MVOLT_HS_ies	4728	0.9	49
	A5	1	Lithonia Lighting	DSX0 LED P2 40K T5M MVOLT SPA DDBXD with SSS 18 4C DM19AS DDBXD	DSX0 LED Area Fixture; mounted at 20ft (18ft pole on 2ft base)	LED	1	DSX0_LED_P2_40K_T5M_MVOLT_ies	6236	0.9	49
	C	2	Lithonia Lighting	VCPG LED V4 P2 40K 80CRI T5M MVOLT XXX UPL1 XXXXX	VCPG LED Canopy Fixture; mounted at 11ft	LED	1	VCPG_LED_P2_40K_T5M_MVOLT_UPL1_ies	5447	0.9	40.36
	W3	1	Lithonia Lighting	WDGE2 LED P4 40K 80CRI VW MVOLT DDBXD	WDGE2 LED Wall Pack; mounted at 16ft	LED	1	WDGE2_LED_P4_40K_80CRI_VW_ies	4526	0.9	34.96
	W4	1	Lithonia Lighting	WDGE2 LED P4 40K 80CRI VF MVOLT DDBXD	WDGE2 LED Wall Pack; mounted at 16ft	LED	1	WDGE2_LED_P4_40K_80CRI_VF_ies	4412	0.9	34.96

Statistics						
Description	Symbol	Avg	Max	Min	Max/Min	Avg/Min
Outside of Parking Lot	+	0.2 fc	4.6 fc	0.0 fc	N/A	N/A
Parking Lot	+	1.2 fc	7.0 fc	0.2 fc	35.0:1	6.0:1
Under Canopy	+	2.7 fc	4.6 fc	0.5 fc	9.2:1	5.4:1

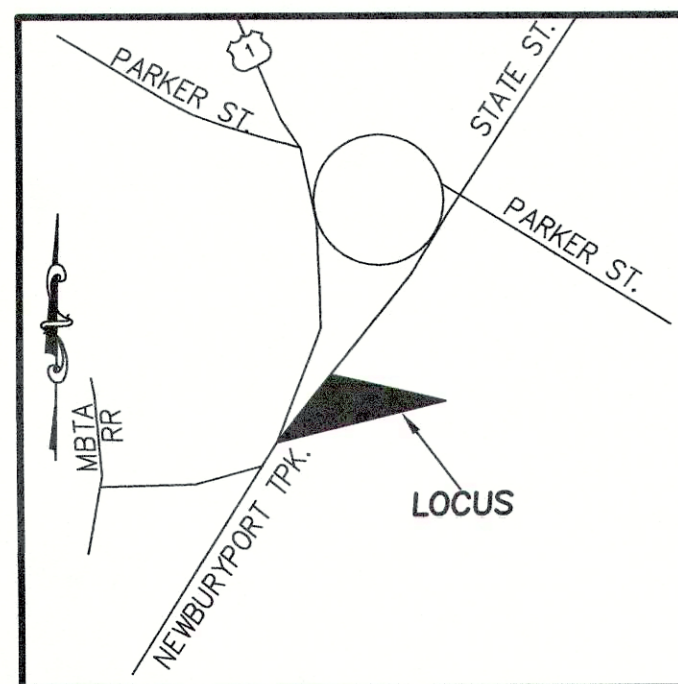

APPROX. LOCATION OF EXISTING 6" C.I. WATER MAIN
 UPOLE#48
 UPOLE#49 W/LAMP
 CB RIM=19.32
 CB RIM=18.6
 DMH RIM=18.9
 DMH RIM=9.5
 CB RIM=19.2
 DMH RIM=19.2
 DMH RIM=19.2

L=332.64' P.K. FND
 R=550.00'



PROPOSED THREE STORY MIXED USE BUILDING
 3,000 S.F. RETAIL
 12,000 S.F. RESIDENTIAL
3S = 21.5

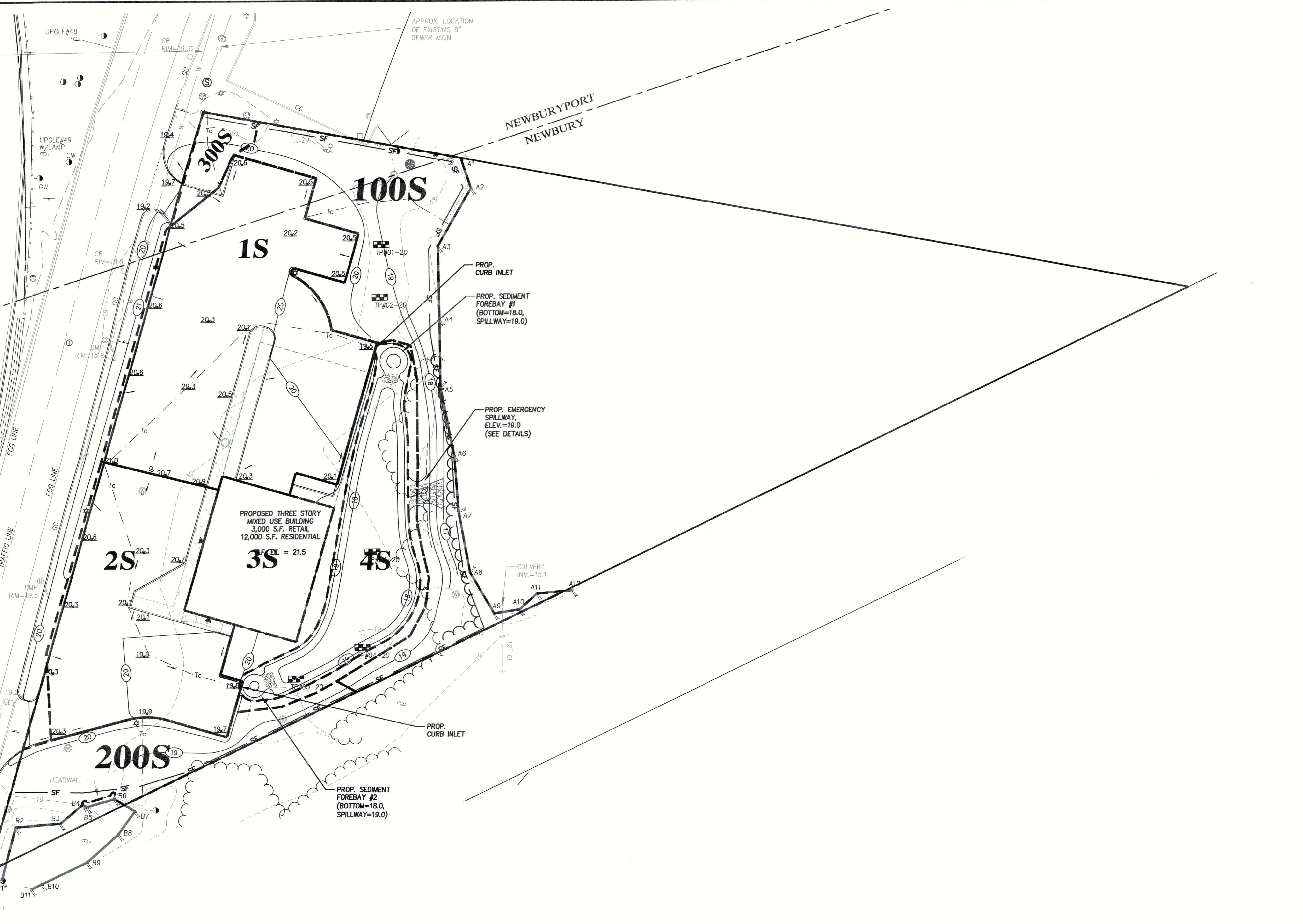

APPROX. LOCATION OF EXISTING 8" SEWER MAIN
 NEWBURYPORT NEWBURY
 PROP. CURB INLET
 PROP. SEDIMENT FOREBAY #1 (BOTTOM=18.0, SPILLWAY=19.0)
 PROP. EMERGENCY SPILLWAY, ELEV.=19.0 (SEE DETAILS)
 PROP. CURB INLET
 PROP. SEDIMENT FOREBAY #2 (BOTTOM=18.0, SPILLWAY=19.0)
 CULVERT INV.=15.1

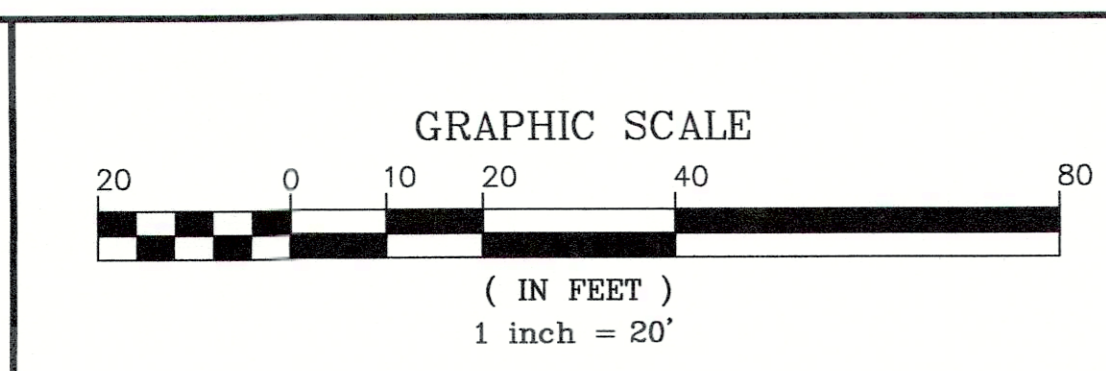

PREPARED FOR
 BAVARO FAMILY REALTY TWO, LLC
 18 GRAF ROAD UNIT #31
 NEWBURYPORT, MA

MEI MILLENNIUM ENGINEERING, INC.
 ENGINEERING AND LAND SURVEYING
 62 ELM ST. SALISBURY, MA 01952 (978) 463-8980
 13 HAMPTON RD. EXETER, NH 03833 (603) 778-0528

SCALE: 1"=20'
 DATE: JUN. 29, 2020

DESIGN BY: C.M.Y.
 CHECKED BY: E.W.B.

PROJECT: M193668

PLAN OF LAND
 IN
NEWBURY, MA
 SHOWING
PROPOSED SITE IMPROVEMENTS
 AT
3 NEWBURYPORT TURNPIKE

**POST-DEV
 WATERSHED
 AREAS**

SHEET: 2 OF 2

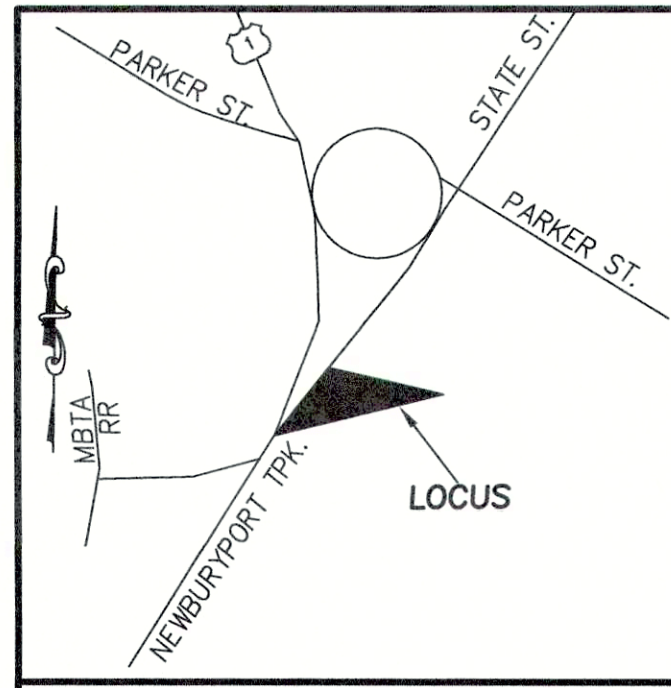

LOCUS MAP
N.T.S.

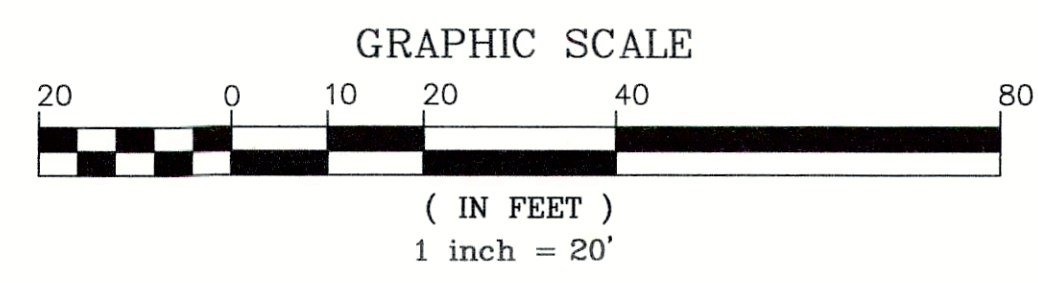
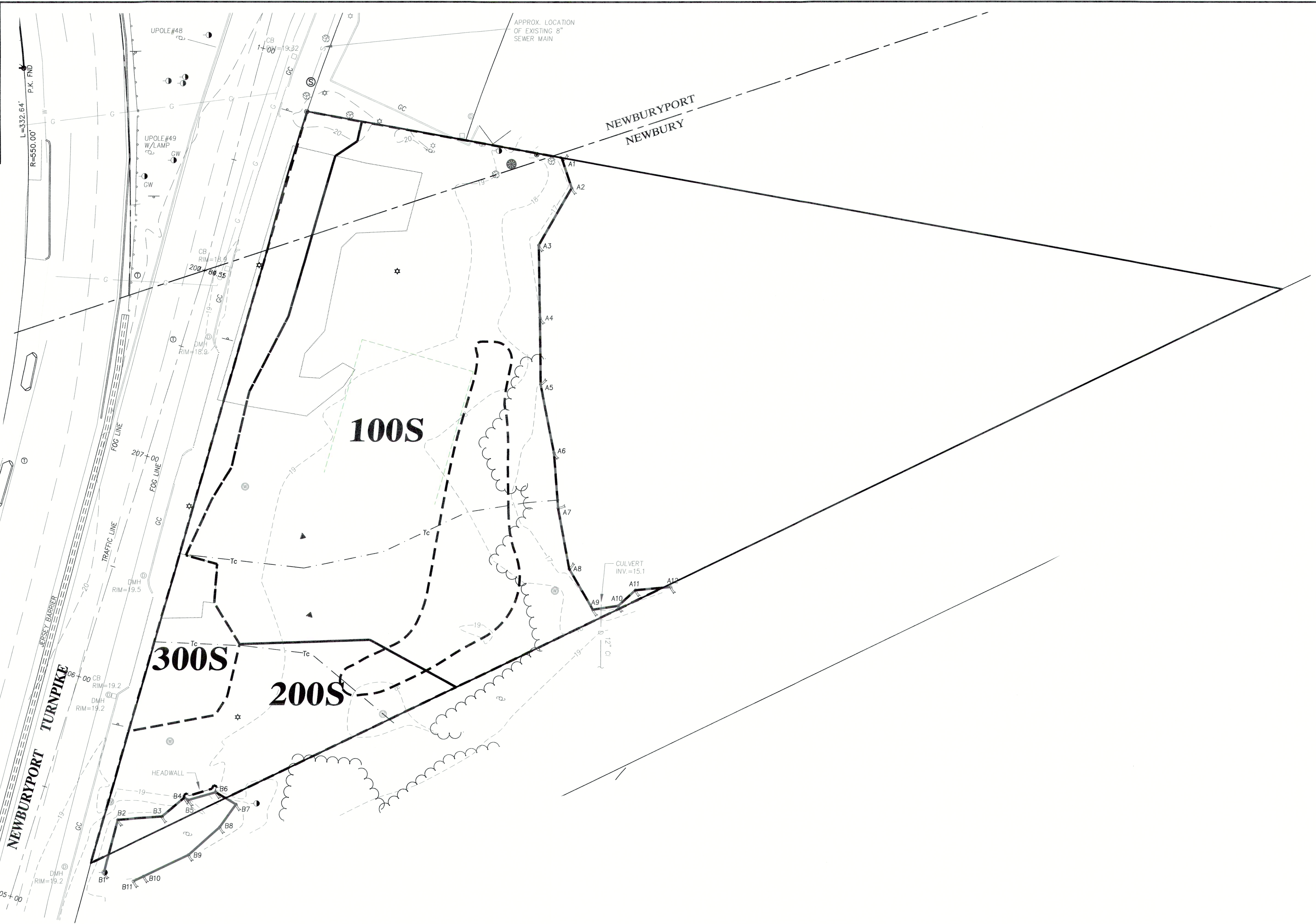

PREPARED FOR
BAVARO FAMILY REALTY TWO, LLC
 18 GRAF ROAD UNIT #31
 NEWBURYPORT, MA

MEI **MILLENNIUM ENGINEERING, INC.**
 ENGINEERING AND LAND SURVEYING
 62 ELM ST. SALISBURY, MA 01952 (978) 463-8980
 13 HAMPTON RD. EXETER, NH 03833 (603) 778-0528

PLAN OF LAND
 IN
NEWBURY, MA
 SHOWING
PROPOSED SITE IMPROVEMENTS
 AT
3 NEWBURYPORT TURNPIKE

**PRE-DEV
 WATERSHED
 AREAS**

E:\pdkproj-2019\M193668\dwg\M193668-B.dwg 12/3/2019 12:39:18 PM EST

STORMWATER MANAGEMENT REPORT

FOR: BAVARO FAMILY REALTY TWO, LLC

PROPOSED MIXED-USE DEVELOPMENT

3 NEWBURYPORT TURNPIKE

NEWBURY, MA

TAX MAP R47 LOT No. 39

PREPARED BY:

MILLENNIUM ENGINEERING, INC.

62 ELM STREET

SALISBURY, MA 01952

(978) 463-8980

AUGUST 27, 2020



Christ M. York 8-27-20

1.0 INTRODUCTION

1.1 Project Description

Bavaro Family Realty Two, LLC proposes to construct a mixed-use development at 3 Newburyport Turnpike in Newbury, MA. A stormwater management system will be constructed to support the development. The development will connect to municipal water and sewer and private utilities including electric will also support the development. Access to the site will continue to be provided via the Newburyport Turnpike (Route 1).

1.2 Existing Site Characteristics

The subject parcel is described as Tax Map R47, Lot No. 39 on the Town of Newbury, MA Assessor's Map and is bordered by Newburyport Turnpike to the west. The Town line intersects the northwest corner of the property. The project parcel is 1.67 acres in size. Elevations on the site range from 20.00' in the northwest corner of the parcel to 17.00' at the wetlands at the rear of the parcel. These elevations are based upon 1988 NAV datum.

In general, the property is triangular in shape and fronts the Newburyport Turnpike (Route 1). A large wetland resource area with surface water is present in the eastern portion of the property with upland dominating the western portion of the property. No buildings are present on the property, although impervious surfaces are present from previous development on the site. See the accompanying plan for a more detailed description of the existing site conditions and topography.

The lot consists of two soil groups: Udorthents, 651 (Hydrologic Soil Group A); and Freetown muck, 52A (Hydrologic Soil Group B/D). 5 test pits were performed onsite in February 2020. The test pits indicated sandy soils throughout the site, more indicative of A soils being present throughout the site. See Appendix E for the NRCS soil map.

1.3 Proposed Site Features

The Applicant proposes to construct a three-story building with retail space (3,000 sf) on the first floor and twelve residential units (12,000 sf) located on the second and third floors. The second and third floors will be cantilevered over six parking spaces resulting in podium parking for those six spaces. Access to the property will be via a one-way driveway entrance off the northbound Newbury Turnpike. A second driveway opening, dedicated to exit only, is provided in the northern portion of the property that also connects to the northbound Newburyport Turnpike. Paved parking is located in front of and to the sides of the building. Underground electrical and telecommunications service will also be provided. Sewer and water services are proposed to be connected to the City of Newburyport's 8" sewer main and 6" water main located in the Newburyport Turnpike Right of Way.

In order to address stormwater management regulations, sediment forebays and an infiltration basin are proposed to treat, store, and infiltrate runoff.

2.0 WATERSHED ANALYSIS AND METHODOLOGY

The stormwater runoff management system was analyzed using the storm events of the 2-year, 10-year and 100-year frequency. The analysis was performed using HydroCAD, version 10.00. Using USDA NRCS TR-20 and TR-55 methods of estimating runoff, the program uses the measured characteristics of the site and computes runoff produced by simulated rainfall events. The results are then used to design runoff control structures.

Existing drainage area boundaries were developed using an onsite topographic survey performed by Millennium Engineering, Inc. Proposed site development boundaries were developed from proposed grades and ground cover designed to minimize site storm water management structure requirements.

Hydrologic soil groups and curve numbers were estimated for existing and proposed developed conditions using available NRCS Soil Maps, current vegetation, and terrain.

3.0 DRAINAGE ANALYSIS

The purpose of the drainage analysis is two-fold. The first is to analyze and quantify the pre-development runoff flows through the site. The second purpose is to evaluate the impact of the proposed development on drainage patterns and flows, both within and outside the site, and to design a stormwater management system to adequately convey post-development runoff.

The design of the stormwater management system has the following goals:

- 1.) Minimize or eliminate erosion and sedimentation during construction as well as after development.
- 2.) To ensure that post-development flows do not have an adverse affect on downstream drainage structures and landowners.
- 3.) To design a stormwater and treatment system which will carry the surface runoff and satisfy goals one and two.

To determine the hydrological effect of the proposed development on the watershed, the existing conditions must first be analyzed.

4.0 WATERSHED DESCRIPTION: EXISTING CONDITIONS

Depending on the soil classification, type of ground cover present and the direction of the flow of runoff, the existing site is divided into watershed areas. Watershed area 100 consists of the majority of the site and it feeds the bordering vegetated wetlands series "A"

at the rear of the property. Area 200 consists of the southerly edge of the site and it feeds the bordering vegetated wetlands series “B”. Area 300 consists of the extreme front of the site and it flows onto Route 1. See the attached plans (Watersheds and HydroCad Data, sheet 1 of 2) for the watershed area boundaries and the pre-development time of concentration flow paths.

4.1 WATERSHED ANALYSIS: EXISTING CONDITIONS

The existing conditions were modeled using the tabular hydrograph method with a Type III synthetic storm distribution for the 2, 10 and 100-year storm recurrence intervals. Runoff hydrographs were produced to estimate existing peak discharge.

Flows for the three storm simulations are as follows:

Existing (Pre-development) Peak Runoff Rates (c.f.s.)

Subcatchment	Size (Acres)	2 Yr Storm	10 Yr Storm	100 Yr Storm
100	0.66	0.0	0.3	1.0
200	0.13	0.0	0.0	0.2
300	0.11	0.1	0.2	0.4
		2 Yr	10 Yr	100 Yr
Pond		0.0	0.3	1.0
Wetlands		0.0	0.0	0.2
Route 1		0.1	0.2	0.4

The pre-development drainage calculations can be found in Appendix C.

5.0 WATERSHED DESCRIPTION: POST-DEVELOPMENT CONDITIONS

To determine the post development runoff, new watersheds, runoff curve numbers and times of concentration were generated reflecting the changes in the topography and surface cover. The post-development watersheds are shown on the attached plans (Watersheds and HydroCad Data, sheet 2 of 2). Watershed area 1S consists of the paved area in front of and to the north of the proposed building and it feeds the infiltration basin. Area 2S consists of the paved area in front of and to the south of the proposed building and it feeds the infiltration basin. Area 3S consists of the proposed building and it feeds the infiltration basin. Area 4S consists of the area behind the building and including the infiltration basin. Area 100 consists of the extreme rear of the site and it feeds the bordering vegetated wetlands series “A” at the rear of the property. Area 200 consists of the southerly edge of the site and it feeds the bordering vegetated wetlands series “B”. Area 300 consists of the very front of the proposed driveways and it flows onto Route 1.

5.1 WATERSHED ANALYSIS: POST-DEVELOPMENT CONDITIONS

The proposed developed conditions were modeled using the tabular hydrograph method with a Type III synthetic storm distribution for the 2, 10 and 100-year storm recurrence intervals. Runoff hydrographs were produced to estimate the post-development peak discharge.

Flows for the three storm simulations are as follows:

Post-Developed Peak Runoff Rates (c.f.s.)

Subcatchment	Size (Acres)	2 Yr Storm	10 Yr Storm	100 Yr Storm
1S	0.26	0.7	1.1	1.6
2S	0.16	0.5	0.8	1.2
3S	0.07	0.2	0.3	0.4
4S	0.14	0.0	0.0	0.0
100	0.18	0.0	0.0	0.0
200	0.08	0.0	0.0	0.0
300	0.02	0.0	0.0	0.1
		2 Yr	10 Yr	100 Yr
Pond		0.0	0.0	1.0
Wetlands		0.0	0.0	0.0
Route 1		0.0	0.0	0.0

The post-development drainage calculations can be found in Appendix D.

6.0 STORMWATER STANDARDS CALCULATIONS

The Stormwater Management Plan developed for this project incorporates water quantity and quality controls that will protect surface and groundwater resources and adjacent properties from potential impacts due to increased impervious areas on the site. The following provides a brief discussion on how the proposed project will meet the ten established performance standards of the DEP Stormwater Management Policy.

1. No new stormwater conveyances (e.g. outfalls) may discharge untreated stormwater directly to or cause erosion in wetlands or waters of the Commonwealth.

No proposed site stormwater conveyance systems will discharge untreated stormwater directly to wetlands or surrounding areas. Stormwater runoff from the roofs and proposed paved area will discharge into the proposed constructed wetland.

2. Stormwater management systems shall be designed so that post-development peak discharge rates do not exceed pre-development peak discharge rates. This Standard may be waived for discharges to land subject to coastal storm flowage as defined in 310 CMR 10.04.

Stormwater runoff peak discharge rates from the proposed development are less than existing conditions for the 2-yr, 10-yr, and 100-yr 24-hour Type III storm events.

3. Loss of annual recharge to groundwater shall be eliminated or minimized through the use of infiltration measures including environmentally sensitive site design, low impact development techniques, stormwater best management practices, and good operation and maintenance. At a minimum, the annual recharge from the post-development site shall approximate the annual recharge from pre-development conditions based on soil type. This Standard is met when the stormwater management system is designed to infiltrate the required recharge volume as determined in accordance with the Massachusetts Stormwater Handbook.

$$\begin{aligned} \text{Required Recharge volume, } R_v (\text{A soil}) &= F * \text{impervious area} \\ &= 0.60 \text{ in} * 20,625 \text{ s.f.} \\ &= 1,031 \text{ c.f.} \end{aligned}$$

Total Recharge provided = 4,976 c.f.

Drawdown Calculation

$$\text{Drawdown Time} = \frac{R_v}{(K) (\text{Bottom Area})}$$

R_v = Storage Volume = 4,976 c.f.

K = Saturated Hydraulic Conductivity = 2.41 in./hr

Bottom Area = 2,430 s.f.

$$\text{Drawdown Time} = \frac{4,976 \text{ c.f.}}{(2.41 \text{ in/hr})(1 \text{ ft}/12 \text{ in})(2,430 \text{ s.f.})}$$

Drawdown Time = 10.2 hours

4. Stormwater management systems shall be designed to remove 80% of the average annual post-construction load of Total Suspended Solids (TSS). This Standard is met when:

- a. Suitable practices for source control and pollution prevention are identified in a long-term pollution prevention plan, and thereafter are implemented and maintained;
- b. Structural stormwater best management practices are sized to capture the required water quality volume determined in accordance with the Massachusetts Stormwater Handbook; and

c. Pretreatment is provided in accordance with the Massachusetts Stormwater Handbook.

The Massachusetts DEP requires water quality calculations based on 0.5 inch of runoff for the total impervious area associated with the proposed development. The following calculation identifies the water quality volume required.

Total Impervious Area = 20,625 s.f.
20,625 s.f. * .5" / 12 (to convert to ft) = 859 c.f. of runoff to be treated for water quality.

Volume of Infiltration Basin = 4,976 c.f.

The proposed development's drainage system must meet the MA Office of Coastal Zone management (CZM)/MA Department of Environmental Protection (DEP) Stormwater Management policy standard of removing 80% of the average annual load of Total Suspended Solids (TSS). The stormwater management system for this development will include the use of sediment forebays for pre-treatment, and an infiltration basin for treatment prior to discharge into the resource areas. The following demonstrates that the proposed storm water management system for the development satisfies the requirement for treatment of 80% of total Suspended Solids:

Infiltration Basin 80%

5. For land uses with higher potential pollutant loads, source control and pollution prevention shall be implemented in accordance with the Massachusetts Stormwater Handbook to eliminate or reduce the discharge of stormwater runoff from such land uses to the maximum extent practicable. If through source control and/or pollution prevention all land uses with higher potential pollutant loads cannot be completely protected from exposure to rain, snow, snow melt, and stormwater runoff, the proponent shall use the specific structural stormwater BMPs determined by the Department to be suitable for such uses as provided in the Massachusetts Stormwater Handbook. Stormwater discharges from land uses with higher potential pollutant loads shall also comply with the requirements of the Massachusetts Clean Waters Act, M.G.L. c. 21, §§ 26-53 and the regulations promulgated there under at 314 CMR 3.00, 314 CMR 4.00 and 314 CMR 5.00.

This project does not qualify as a land use with higher potential pollutant loads.

6. Stormwater discharges within the Zone II or Interim Wellhead Protection Area of a public water supply, and stormwater discharges near or to any other critical area, require the use of the specific source control and pollution prevention measures and the specific structural stormwater best management practices determined by the Department to be suitable for managing discharges to such areas, as provided in the Massachusetts Stormwater Handbook. A discharge is near a critical area if there is a strong likelihood of a significant impact occurring to said area, taking into account site-specific factors. Stormwater discharges to Outstanding Resource Waters and Special Resource Waters

shall be removed and set back from the receiving water or wetland and receive the highest and best practical method of treatment. A "storm water discharge" as defined in 314 CMR 3.04(2)(a)1 or (b) to an Outstanding Resource Water or Special Resource Water shall comply with 314 CMR 3.00 and 314 CMR 4.00. Stormwater discharges to a Zone I or Zone A are prohibited unless essential to the operation of a public water supply.

This project does not fall within a critical area.

7. A redevelopment project is required to meet the following Stormwater Management Standards only to the maximum extent practicable: Standard 2, Standard 3, and the pretreatment and structural best management practice requirements of Standards 4, 5, and 6. Existing stormwater discharges shall comply with Standard 1 only to the maximum extent practicable. A redevelopment project shall also comply with all other requirements of the Stormwater Management Standards and improve existing conditions.

The proposed development is not considered a redevelopment project and does not meet the requirements of definition for this standard.

8. A plan to control construction-related impacts including erosion, sedimentation and other pollutant sources during construction and land disturbance activities (construction period erosion, sedimentation, and pollution prevention plan) shall be developed and implemented.

The proposed development design includes erosion and sediment controls to minimize the potential for sedimentation in down gradient resource areas. Reference is made to the project plans for additional information.

9. A long-term operation and maintenance plan shall be developed and implemented to ensure that stormwater management systems function as designed.

An O&M plan has been developed and is included in this report.

10. All illicit discharges to the stormwater management system are prohibited.

No illicit discharges exist on the site.

7.0 CONCLUSIONS

The results of this report indicate the proposed stormwater management system for the proposed development is capable of storing and treating the runoff for the 2-year, 10-year and 100-year storm events.

The peak flow rates in this analysis have been conservatively estimated for both the pre- and post-development conditions. Based on the results of the analyses described herein, the proposed development will not increase in the existing the runoff rate leaving the site.

The proposed storm water management facilities shown on the Site Plan will produce no adverse storm water runoff impacts under the storms analyzed.

8.0 APPENDIX A – STORMWATER REPORT CHECKLIST



Checklist for Stormwater Report

A. Introduction

Important: When filling out forms on the computer, use only the tab key to move your cursor - do not use the return key.



A Stormwater Report must be submitted with the Notice of Intent permit application to document compliance with the Stormwater Management Standards. The following checklist is NOT a substitute for the Stormwater Report (which should provide more substantive and detailed information) but is offered here as a tool to help the applicant organize their Stormwater Management documentation for their Report and for the reviewer to assess this information in a consistent format. As noted in the Checklist, the Stormwater Report must contain the engineering computations and supporting information set forth in Volume 3 of the Massachusetts Stormwater Handbook. The Stormwater Report must be prepared and certified by a Registered Professional Engineer (RPE) licensed in the Commonwealth.

The Stormwater Report must include:

- The Stormwater Checklist completed and stamped by a Registered Professional Engineer (see page 2) that certifies that the Stormwater Report contains all required submittals.¹ This Checklist is to be used as the cover for the completed Stormwater Report.
- Applicant/Project Name
- Project Address
- Name of Firm and Registered Professional Engineer that prepared the Report
- Long-Term Pollution Prevention Plan required by Standards 4-6
- Construction Period Pollution Prevention and Erosion and Sedimentation Control Plan required by Standard 8²
- Operation and Maintenance Plan required by Standard 9

In addition to all plans and supporting information, the Stormwater Report must include a brief narrative describing stormwater management practices, including environmentally sensitive site design and LID techniques, along with a diagram depicting runoff through the proposed BMP treatment train. Plans are required to show existing and proposed conditions, identify all wetland resource areas, NRCS soil types, critical areas, Land Uses with Higher Potential Pollutant Loads (LUHPPL), and any areas on the site where infiltration rate is greater than 2.4 inches per hour. The Plans shall identify the drainage areas for both existing and proposed conditions at a scale that enables verification of supporting calculations.

As noted in the Checklist, the Stormwater Management Report shall document compliance with each of the Stormwater Management Standards as provided in the Massachusetts Stormwater Handbook. The soils evaluation and calculations shall be done using the methodologies set forth in Volume 3 of the Massachusetts Stormwater Handbook.

To ensure that the Stormwater Report is complete, applicants are required to fill in the Stormwater Report Checklist by checking the box to indicate that the specified information has been included in the Stormwater Report. If any of the information specified in the checklist has not been submitted, the applicant must provide an explanation. The completed Stormwater Report Checklist and Certification

¹ The Stormwater Report may also include the Illicit Discharge Compliance Statement required by Standard 10. If not included in the Stormwater Report, the Illicit Discharge Compliance Statement must be submitted prior to the discharge of stormwater runoff to the post-construction best management practices.

² For some complex projects, it may not be possible to include the Construction Period Erosion and Sedimentation Control Plan in the Stormwater Report. In that event, the issuing authority has the discretion to issue an Order of Conditions that approves the project and includes a condition requiring the proponent to submit the Construction Period Erosion and Sedimentation Control Plan before commencing any land disturbance activity on the site.

B. Stormwater Checklist and Certification



Checklist for Stormwater Report

The following checklist is intended to serve as a guide for applicants as to the elements that ordinarily need to be addressed in a complete Stormwater Report. The checklist is also intended to provide conservation commissions and other reviewing authorities with a summary of the components necessary for a comprehensive Stormwater Report that addresses the ten Stormwater Standards.

Note: Because stormwater requirements vary from project to project, it is possible that a complete Stormwater Report may not include information on some of the subjects specified in the Checklist. If it is determined that a specific item does not apply to the project under review, please note that the item is not applicable (N.A.) and provide the reasons for that determination.

A complete checklist must include the Certification set forth below signed by the Registered Professional Engineer who prepared the Stormwater Report.

Registered Professional Engineer's Certification

I have reviewed the Stormwater Report, including the soil evaluation, computations, Long-term Pollution Prevention Plan, the Construction Period Erosion and Sedimentation Control Plan (if included), the Long-term Post-Construction Operation and Maintenance Plan, the Illicit Discharge Compliance Statement (if included) and the plans showing the stormwater management system, and have determined that they have been prepared in accordance with the requirements of the Stormwater Management Standards as further elaborated by the Massachusetts Stormwater Handbook. I have also determined that the information presented in the Stormwater Checklist is accurate and that the information presented in the Stormwater Report accurately reflects conditions at the site as of the date of this permit application.

Registered Professional Engineer Block and Signature

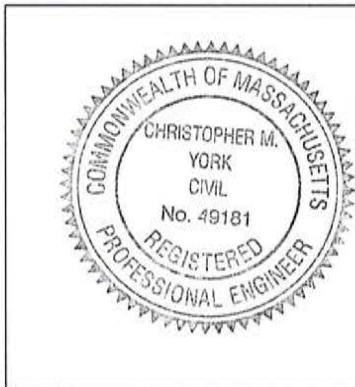

Christ M. York

8-27-20

Signature and Date

Checklist

Project Type: Is the application for new development, redevelopment, or a mix of new and redevelopment?

- New development
- Redevelopment
- Mix of New Development and Redevelopment

Checklist (continued)



Checklist for Stormwater Report

LID Measures: Stormwater Standards require LID measures to be considered. Document what environmentally sensitive design and LID Techniques were considered during the planning and design of the project:

- No disturbance to any Wetland Resource Areas
- Site Design Practices (e.g. clustered development, reduced frontage setbacks)
- Reduced Impervious Area (Redevelopment Only)
- Minimizing disturbance to existing trees and shrubs
- LID Site Design Credit Requested:
 - Credit 1
 - Credit 2
 - Credit 3
- Use of "country drainage" versus curb and gutter conveyance and pipe
- Bioretention Cells (includes Rain Gardens)
- Constructed Stormwater Wetlands (includes Gravel Wetlands designs)
- Treebox Filter
- Water Quality Swale
- Grass Channel
- Green Roof
- Other (describe): Infiltration Basin

Standard 1: No New Untreated Discharges

- No new untreated discharges
- Outlets have been designed so there is no erosion or scour to wetlands and waters of the Commonwealth
- Supporting calculations specified in Volume 3 of the Massachusetts Stormwater Handbook included.

Checklist (continued)



Checklist for Stormwater Report

Standard 2: Peak Rate Attenuation

- Standard 2 waiver requested because the project is located in land subject to coastal storm flowage and stormwater discharge is to a wetland subject to coastal flooding.
- Evaluation provided to determine whether off-site flooding increases during the 100-year 24-hour storm.
- Calculations provided to show that post-development peak discharge rates do not exceed pre-development rates for the 2-year and 10-year 24-hour storms. If evaluation shows that off-site flooding increases during the 100-year 24-hour storm, calculations are also provided to show that post-development peak discharge rates do not exceed pre-development rates for the 100-year 24-hour storm.

Standard 3: Recharge

- Soil Analysis provided.
- Required Recharge Volume calculation provided.
- Required Recharge volume reduced through use of the LID site Design Credits.
- Sizing the infiltration, BMPs is based on the following method: Check the method used.
 - Static
 - Simple Dynamic
 - Dynamic Field¹
- Runoff from all impervious areas at the site discharging to the infiltration BMP.
- Runoff from all impervious areas at the site is *not* discharging to the infiltration BMP and calculations are provided showing that the drainage area contributing runoff to the infiltration BMPs is sufficient to generate the required recharge volume.
- Recharge BMPs have been sized to infiltrate the Required Recharge Volume.
- Recharge BMPs have been sized to infiltrate the Required Recharge Volume *only* to the maximum extent practicable for the following reason:
 - Site is comprised solely of C and D soils and/or bedrock at the land surface
 - M.G.L. c. 21E sites pursuant to 310 CMR 40.0000
 - Solid Waste Landfill pursuant to 310 CMR 19.000
 - Project is otherwise subject to Stormwater Management Standards only to the maximum extent practicable.
- Calculations showing that the infiltration BMPs will drain in 72 hours are provided.
- Property includes a M.G.L. c. 21E site or a solid waste landfill and a mounding analysis is included.

¹ 80% TSS removal is required prior to discharge to infiltration BMP if Dynamic Field method is used.

Checklist (continued)



Checklist for Stormwater Report

Standard 3: Recharge (continued)

- The infiltration BMP is used to attenuate peak flows during storms greater than or equal to the 10-year 24-hour storm and separation to seasonal high groundwater is less than 4 feet and a mounding analysis is provided.
- Documentation is provided showing that infiltration BMPs do not adversely impact nearby wetland resource areas.

Standard 4: Water Quality

The Long-Term Pollution Prevention Plan typically includes the following:

- Good housekeeping practices;
 - Provisions for storing materials and waste products inside or under cover;
 - Vehicle washing controls;
 - Requirements for routine inspections and maintenance of stormwater BMPs;
 - Spill prevention and response plans;
 - Provisions for maintenance of lawns, gardens, and other landscaped areas;
 - Requirements for storage and use of fertilizers, herbicides, and pesticides;
 - Pet waste management provisions;
 - Provisions for operation and management of septic systems;
 - Provisions for solid waste management;
 - Snow disposal and plowing plans relative to Wetland Resource Areas;
 - Winter Road Salt and/or Sand Use and Storage restrictions;
 - Street sweeping schedules;
 - Provisions for prevention of illicit discharges to the stormwater management system;
 - Documentation that Stormwater BMPs are designed to provide for shutdown and containment in the event of a spill or discharges to or near critical areas or from LUHPPL;
 - Training for staff or personnel involved with implementing Long-Term Pollution Prevention Plan;
 - List of Emergency contacts for implementing Long-Term Pollution Prevention Plan.
- A Long-Term Pollution Prevention Plan is attached to Stormwater Report and is included as an attachment to the Wetlands Notice of Intent.
 - Treatment BMPs subject to the 44% TSS removal pretreatment requirement and the one inch rule for calculating the water quality volume are included, and discharge:
 - is within the Zone II or Interim Wellhead Protection Area
 - is near or to other critical areas
 - is within soils with a rapid infiltration rate (greater than 2.4 inches per hour)
 - involves runoff from land uses with higher potential pollutant loads.
 - The Required Water Quality Volume is reduced through use of the LID site Design Credits.
 - Calculations documenting that the treatment train meets the 80% TSS removal requirement and, if applicable, the 44% TSS removal pretreatment requirement, are provided.

Checklist (continued)



Checklist for Stormwater Report

Standard 4: Water Quality (continued)

- The BMP is sized (and calculations provided) based on:
 - The ½" or 1" Water Quality Volume or
 - The equivalent flow rate associated with the Water Quality Volume and documentation is provided showing that the BMP treats the required water quality volume.
- The applicant proposes to use proprietary BMPs, and documentation supporting use of proprietary BMP and proposed TSS removal rate is provided. This documentation may be in the form of the propriety BMP checklist found in Volume 2, Chapter 4 of the Massachusetts Stormwater Handbook and submitting copies of the TARP Report, STEP Report, and/or other third party studies verifying performance of the proprietary BMPs.
- A TMDL exists that indicates a need to reduce pollutants other than TSS and documentation showing that the BMPs selected are consistent with the TMDL is provided.

Standard 5: Land Uses With Higher Potential Pollutant Loads (LUHPPLs)

- The NPDES Multi-Sector General Permit covers the land use and the Stormwater Pollution Prevention Plan (SWPPP) has been included with the Stormwater Report.
- The NPDES Multi-Sector General Permit covers the land use and the SWPPP will be submitted *prior* to the discharge of stormwater to the post-construction stormwater BMPs.
- The NPDES Multi-Sector General Permit does *not* cover the land use.
- LUHPPLs are located at the site and industry specific source control and pollution prevention measures have been proposed to reduce or eliminate the exposure of LUHPPLs to rain, snow, snow melt and runoff, and been included in the long term Pollution Prevention Plan.
- All exposure has been eliminated.
- All exposure has *not* been eliminated and all BMPs selected are on MassDEP LUHPPL list.
- The LUHPPL has the potential to generate runoff with moderate to higher concentrations of oil and grease (e.g. all parking lots with >1000 vehicle trips per day) and the treatment train includes an oil grit separator, a filtering bioretention area, a sand filter or equivalent.

Standard 6: Critical Areas

- The discharge is near or to a critical area and the treatment train includes only BMPs that MassDEP has approved for stormwater discharges to or near that particular class of critical area.
- Critical areas and BMPs are identified in the Stormwater Report.

Checklist (continued)



Checklist for Stormwater Report

Standard 7: Redevelopments and Other Projects Subject to the Standards only to the maximum extent practicable

- The project is subject to the Stormwater Management Standards only to the maximum Extent Practicable as a:
 - Limited Project
 - Small Residential Projects: 5-9 single family houses or 5-9 units in a multi-family development provided there is no discharge that may potentially affect a critical area.
 - Small Residential Projects: 2-4 single family houses or 2-4 units in a multi-family development with a discharge to a critical area
 - Marina and/or boatyard provided the hull painting, service and maintenance areas are protected from exposure to rain, snow, snow melt and runoff
 - Bike Path and/or Foot Path
 - Redevelopment Project
 - Redevelopment portion of mix of new and redevelopment.
- Certain standards are not fully met (Standard No. 1, 8, 9, and 10 must always be fully met) and an explanation of why these standards are not met is contained in the Stormwater Report.
- The project involves redevelopment and a description of all measures that have been taken to improve existing conditions is provided in the Stormwater Report. The redevelopment checklist found in Volume 2 Chapter 3 of the Massachusetts Stormwater Handbook may be used to document that the proposed stormwater management system (a) complies with Standards 2, 3 and the pretreatment and structural BMP requirements of Standards 4-6 to the maximum extent practicable and (b) improves existing conditions.

Standard 8: Construction Period Pollution Prevention and Erosion and Sedimentation Control

A Construction Period Pollution Prevention and Erosion and Sedimentation Control Plan must include the following information:

- Narrative;
 - Construction Period Operation and Maintenance Plan;
 - Names of Persons or Entity Responsible for Plan Compliance;
 - Construction Period Pollution Prevention Measures;
 - Erosion and Sedimentation Control Plan Drawings;
 - Detail drawings and specifications for erosion control BMPs, including sizing calculations;
 - Vegetation Planning;
 - Site Development Plan;
 - Construction Sequencing Plan;
 - Sequencing of Erosion and Sedimentation Controls;
 - Operation and Maintenance of Erosion and Sedimentation Controls;
 - Inspection Schedule;
 - Maintenance Schedule;
 - Inspection and Maintenance Log Form.
- A Construction Period Pollution Prevention and Erosion and Sedimentation Control Plan containing the information set forth above has been included in the Stormwater Report.

Checklist (continued)



Checklist for Stormwater Report

Standard 8: Construction Period Pollution Prevention and Erosion and Sedimentation Control (continued)

- The project is highly complex and information is included in the Stormwater Report that explains why it is not possible to submit the Construction Period Pollution Prevention and Erosion and Sedimentation Control Plan with the application. A Construction Period Pollution Prevention and Erosion and Sedimentation Control has **not** been included in the Stormwater Report but will be submitted **before** land disturbance begins.
- The project is **not** covered by a NPDES Construction General Permit.
- The project is covered by a NPDES Construction General Permit and a copy of the SWPPP is in the Stormwater Report.
- The project is covered by a NPDES Construction General Permit but no SWPPP been submitted. The SWPPP will be submitted BEFORE land disturbance begins.

Standard 9: Operation and Maintenance Plan

- The Post Construction Operation and Maintenance Plan is included in the Stormwater Report and includes the following information:
 - Name of the stormwater management system owners;
 - Party responsible for operation and maintenance;
 - Schedule for implementation of routine and non-routine maintenance tasks;
 - Plan showing the location of all stormwater BMPs maintenance access areas;
 - Description and delineation of public safety features;
 - Estimated operation and maintenance budget; and
 - Operation and Maintenance Log Form.
- The responsible party is **not** the owner of the parcel where the BMP is located and the Stormwater Report includes the following submissions:
 - A copy of the legal instrument (deed, homeowner's association, utility trust or other legal entity) that establishes the terms of and legal responsibility for the operation and maintenance of the project site stormwater BMPs;
 - A plan and easement deed that allows site access for the legal entity to operate and maintain BMP functions.

Standard 10: Prohibition of Illicit Discharges

- The Long-Term Pollution Prevention Plan includes measures to prevent illicit discharges;
- An Illicit Discharge Compliance Statement is attached;
- NO Illicit Discharge Compliance Statement is attached but will be submitted **prior to** the discharge of any stormwater to post-construction BMPs.

**9.0 APPENDIX B – LONG-TERM POLLUTION PREVENTION PLAN AND
OPERATION & MAINTENANCE PLAN**

This long-term Stormwater Management System Operations and Maintenance (O&M) Plan, filed with the Town of Newbury, shall be implemented for the proposed development at 3 Newburyport Turnpike to ensure that the stormwater management system functions as designed. The Owner holds the primary responsibility for overseeing and implementing the O&M Plan and assigning a Property Manager who will be responsible for the proper operation and maintenance of the stormwater structures. In case of transfer of property ownership, future property owners shall be notified of the presence of the stormwater management system and the requirements for proper implementation of the O&M Plan. Included in the manual is a Stormwater Management O&M Plan identifying the key components of the stormwater system and a log for tracking inspections and maintenance.

The stormwater management system protects and enhances the stormwater runoff water quality through the removal of sediment and pollutants, and source control significantly reduces the amount of pollutants entering the system. Preventive maintenance of the system will include a comprehensive source reduction program of regular vacuuming and litter removal, and prohibitions on the use of pesticides.

The purpose of the Stormwater Operations and Maintenance (O&M) plan is to ensure inspection of the system, removal of accumulated sediments, oils, and debris, and implementation of corrective action and record keeping activities.

The ongoing responsibility is the Owner, its successors and assigns. Adequate maintenance is defined in this document as good working condition.

Contact information is provided below:

Responsibility for Operations and Maintenance

Bavaro Family Realty Two, LLC
18 Graf Road Unit #31
Newburyport, MA
(781) 389-3159

Illicit Discharge Compliance Statement

I, _____, verify that all illicit discharges to the stormwater management system are prohibited and no illicit discharges exist on the site.

EROSION AND SEDIMENT CONTROL BMPs

Minimize Disturbed Area and Protect Natural Features and Soil

Topsoil

Topsoil stripped from the immediate construction area can be temporarily stockpiled on site providing that the perimeter of the stockpiles is properly staked with silt fence at the toe of slope. The stockpiles shall be in areas that will not interfere with construction and at least 15 feet away from areas of concentrated flows or pavement. The area shall be inspected weekly for erosion and immediately after storm events. Areas on or around the stockpile that have eroded shall be stabilized immediately with erosion controls.

Stabilize Soils

Temporary Stabilization

- All vegetated areas which do not exhibit a minimum of 85% vegetative growth by Oct. 15th, or which are disturbed after Oct. 15th, shall be stabilized by seeding and installing erosion control blankets on slopes greater than 3:1, and seeding and placing 3 to 4 tons of mulch per acre, secured with anchored netting, elsewhere. The placement of erosion control blankets or mulch and netting shall not occur over accumulated snow or on frozen ground and shall be completed in advance of thaw or spring melt events.
- All ditches or swales which do not exhibit a minimum of 85% vegetative growth by Oct. 15th, or which are disturbed after Oct. 15th, shall be stabilized with stone or erosion control blankets appropriate for the design flow conditions.
- After November 15th, incomplete road surfaces, where work has stopped for the winter season, shall be protected with a minimum of 3 inches of crushed gravel.

Protect Slopes

Geotextile erosion control blankets shall be used to provide stabilization for slopes exceeding 3:1. Prepare soil before installing erosion control blanket, including any necessary application of lime, fertilizer, and seed. Begin at the top of the slope by anchoring the blanket in a 6" deep x 6" wide trench with approximately 12" extended beyond the upslope portion of the trench. Anchor the blanket with a row of staples/stakes approximately 12" apart in the bottom of the trench. Backfill and compact the trench after stapling. Apply seed to compacted soil and fold remaining 12" portion of back over seed and compacted soil. Secure over compacted soil with a row of staples/stakes spaced approximately 12" apart across the width of the blanket. Roll erosion control blanket either down or horizontally across the slope. Blanket will unroll with appropriate side against the soil surface. All blankets must be securely fastened to soil surface by placing staples/stakes in appropriate locations as shown in the staple pattern guide. When using the dot system, staples/stakes should be placed through each of the colored dots corresponding to the appropriate staple pattern. The edges of parallel blankets must be stapled with approximately 2"-5" overlap. Consecutive blankets spliced down the slope must be placed end over end (shingle style) with an approximate 3" overlap. Staple through

overlapped area, approximately 12" apart across entire blanket's width. In loose soil conditions, the use of staple or stake lengths greater than 6" may be necessary to properly anchor the blanket.

Establish Perimeter Controls and Sediment Barriers

Silt fence shall be installed along the edge of wetlands. The silt fence shall be installed before construction begins. Wooden posts shall be doubled and coupled at filter cloth seams. Filter cloth shall be fastened securely to support netting with ties spaced every 24" at top, midsection, and bottom. When two sections of filter cloth adjoin each other, they shall be overlapped by 6 inches, folded and stapled. Silt fence shall be removed upon completion of the project and stabilization of all soil.

Maintenance:

1. Silt fence shall be inspected immediately after each rainfall and at least daily during prolonged rainfall. Any repairs that are required shall be made immediately.
2. If the fabric on the silt fence shall decompose or become ineffective during the expected life of the fence, the fabric shall be replaced promptly.
3. Sediment deposits shall be inspected after every storm event. The deposits shall be removed when they reach approximately one-half the height of the barrier.
4. Sediment deposits that are removed or left in place after the fabric has been removed shall be graded to conform with the existing topography and vegetated.

Establish Stabilized Construction Entrance

A stabilized construction entrance shall be installed before construction begins on the site. The stone anti-tracking pad shall remain in place until the subgrade of pavement is installed.

1. Stone shall be 1-2" stone, reclaimed stone, or recycled concrete equivalent.
2. The length of the stabilized entrance shall not be less than 50'.
3. The thickness of the stone for the stabilized entrance shall not be less than 6".
4. Geotextile filter cloth shall be placed over the entire area prior to placing the stone.
5. All surface water that is flowing to or diverted toward the construction entrance shall be piped beneath the entrance. If piping is impractical, a berm with 5:1 slopes that can be crossed by vehicles may be substituted for the pipe.
6. The entrance shall be maintained in a condition that will prevent tracking or flowing of sediment onto public rights-of-way. This may require periodic top-dressing with additional stone as conditions demand and repair and/or cleanout of any measures used to trap sediment. All sediment spilled, washed, or tracked onto public rights-of-way must be removed promptly.
7. Wheels shall be cleaned to remove mud prior to entrance onto public rights-of way. When washing is required, it shall be done on an area stabilized with stone which drains into an approved sediment trapping device.

Catch Basin Inlet Protection

Inlet protection devices intercept and/or filter sediment before it can be transported from a site into the storm drain system and discharged into a lake, river, stream, wetland, or other waterbody. These devices also keep sediment from filling or clogging storm drain pipes, ditches, and downgradient sediment traps or ponds. A siltsack or approved equal shall be used for catch basin inlet protection. It should be inspected weekly. When the restraint cord is no longer visible, siltsack is full and shall be emptied.

POST-CONSTRUCTION BMPs

Snow and Snow Melt Management

Proper management of snow and snow melt, snow removal and storage, use of deicing compounds, and other practices can minimize major runoff and pollutant loading impacts. Snow will be stored in areas adjacent to the edge of the parking lot. Use of alternative deicing compounds, such as calcium chloride and calcium magnesium acetate, will be investigated for use. Professional services will be used for snow management.

Sediment Forebay

A sediment forebay is included in the stormwater management plan as pretreatment for the proposed infiltration basin. The forebay will be portioned from the basin by use of a stone filter berm. The forebay shall be inspected monthly during construction and cleaned upon completion of the project and thereafter two times per year by a landscaping contractor hired by the owner. Sediments removed during cleaning shall be disposed of at an approved DEP landfill.

Infiltration Basin

An infiltration basin is included in the stormwater management plan design for the proposed development. The applicant of the project, through his contractor, will incorporate this sediment control feature into the project during construction activities. Upon completion of the development, the Owner will be responsible for proper maintenance of the basin. To ensure proper performance and system longevity, the following maintenance schedule is recommended:

- a. Mowing: Basin should be mowed periodically; at least once per month in the spring, summer and fall. The vegetation must not be cut shorter than four inches. All grass clippings should be removed and properly disposed of;
- b. Sediment and debris removal: Basin should be inspected at least twice annually and following any rainfall event exceeding 2.5 inches over a 24-hour period. Any sediment and debris should be removed manually before the vegetation is adversely impacted. At a minimum, accumulated debris should be removed at least once per year to ensure sediments are not re-suspended.

- c. Basin protection: Efforts should be made, through snow and snow melt management, local bylaws and public education, to protect the basin from damages of snow removal and off-street parking.

FINAL STABILIZATION

Permanent Seeding

Loam and hydroseed any disturbed surfaces after the final design grades have been achieved. A minimum of 6" of loam shall be installed. Seed mix shall be a maximum of 10% rye grass and a minimum of 90% permanent bluegrass and/or fescue. Lime shall be applied at a rate of 2 tons/acre.

Construction debris, trash and temporary BMPs (including silt fences, material storage areas, and inlet protection) will also be removed and any areas disturbed during removal will be seeded immediately.

**LONG-TERM POLLUTION PREVENTION PLAN
AND
OPERATION & MAINTENANCE PLAN**

For

**BAVARO FAMILY REALTY TWO, LLC
18 GRAF ROAD UNIT # 31
NEWBURYPORT, MA**

A PROPOSED MIXED-USE DEVELOPMENT

PREPARED BY:

MILLENNIUM ENGINEERING, INC.
62 ELM STREET
SALISBURY, MA 01952
(978) 463-8980

JUNE 22, 2020

PAGE 1 OF 7

POST-CONSTRUCTION INSPECTION & MAINTENANCE LOG

<i>Activity</i>	<i>Date</i>	<i>Inspected By</i>	<i>Findings</i>
Street Sweeping (1x per year)			
Forebay, Infiltration Basin Mowing (1x per month in spring, summer & fall)			
Forebay, Infiltration Basin Sediment Removal (2x per year)			
Rip-rap Outlets & Emergency Spillway Protection (2x per year)			
Vegetation and Landscaping (2x per year)			
Roof Drain Cleanouts (2x per year)			

10.0 APPENDIX C – PRE-DEVELOPMENT DRAINAGE CALCULATIONS

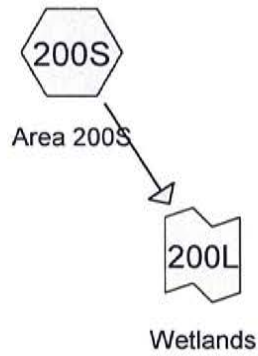
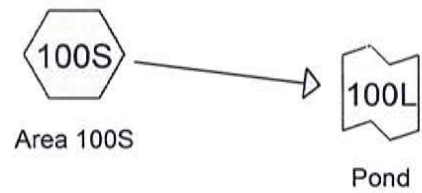
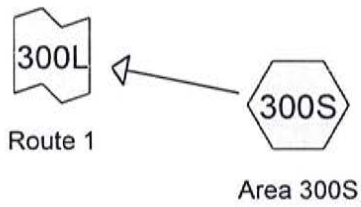

Subcat



Reach

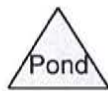

Pond



Link

Routing Diagram for Pre-Dev

Prepared by Millennium Engineering, Inc., Printed 8/27/2020
HydroCAD® 10.00-25 s/n 02736 © 2019 HydroCAD Software Solutions LLC

Pre-Dev

Area Listing (all nodes)

Area (acres)	CN	Description (subcatchment-numbers)
0.730	49	50-75% Grass cover, Fair, HSG A (100S, 200S, 300S)
0.116	98	Paved parking, HSG A (100S, 300S)
0.058	30	Woods, Good, HSG A (100S)
0.904	54	TOTAL AREA

Pre-Dev

Soil Listing (all nodes)

Area (acres)	Soil Group	Subcatchment Numbers
0.904	HSG A	100S, 200S, 300S
0.000	HSG B	
0.000	HSG C	
0.000	HSG D	
0.000	Other	
0.904		TOTAL AREA

Pre-Dev

Ground Covers (all nodes)

HSG-A (acres)	HSG-B (acres)	HSG-C (acres)	HSG-D (acres)	Other (acres)	Total (acres)	Ground Cover	Subcatchment Numbers
0.730	0.000	0.000	0.000	0.000	0.730	50-75% Grass cover, Fair	100S, 200S, 300S
0.116	0.000	0.000	0.000	0.000	0.116	Paved parking	100S, 300S
0.058	0.000	0.000	0.000	0.000	0.058	Woods, Good	100S
0.904	0.000	0.000	0.000	0.000	0.904	TOTAL AREA	

Time span=0.00-24.00 hrs, dt=0.05 hrs, 481 points
Runoff by SCS TR-20 method, UH=SCS, Weighted-CN
Reach routing by Stor-Ind+Trans method - Pond routing by Stor-Ind method

Subcatchment 100S: Area 100S Runoff Area=28,700 sf 9.76% Impervious Runoff Depth>0.15"
Flow Length=166' Tc=7.8 min CN=52 Runoff=0.02 cfs 0.008 af

Subcatchment 200S: Area 200S Runoff Area=5,785 sf 0.00% Impervious Runoff Depth>0.09"
Tc=6.0 min CN=49 Runoff=0.00 cfs 0.001 af

Subcatchment 300S: Area 300S Runoff Area=4,875 sf 45.95% Impervious Runoff Depth>0.87"
Tc=6.0 min CN=72 Runoff=0.10 cfs 0.008 af

Link 100L: Pond Inflow=0.02 cfs 0.008 af
Primary=0.02 cfs 0.008 af

Link 200L: Wetlands Inflow=0.00 cfs 0.001 af
Primary=0.00 cfs 0.001 af

Link 300L: Route 1 Inflow=0.10 cfs 0.008 af
Primary=0.10 cfs 0.008 af

Total Runoff Area = 0.904 ac Runoff Volume = 0.017 af Average Runoff Depth = 0.23"
87.20% Pervious = 0.788 ac 12.80% Impervious = 0.116 ac

Pre-Dev

Prepared by Millennium Engineering, Inc.
 HydroCAD® 10.00-25 s/n 02736 © 2019 HydroCAD Software Solutions LLC

Type III 24-hr 2-Year Rainfall=3.10"

Printed 8/27/2020

Page 6

Summary for Subcatchment 100S: Area 100S

Runoff = 0.02 cfs @ 12.46 hrs, Volume= 0.008 af, Depth> 0.15"

Runoff by SCS TR-20 method, UH=SCS, Weighted-CN, Time Span= 0.00-24.00 hrs, dt= 0.05 hrs
 Type III 24-hr 2-Year Rainfall=3.10"

Area (sf)	CN	Description
23,375	49	50-75% Grass cover, Fair, HSG A
2,525	30	Woods, Good, HSG A
2,800	98	Paved parking, HSG A
28,700	52	Weighted Average
25,900		90.24% Pervious Area
2,800		9.76% Impervious Area

Tc (min)	Length (feet)	Slope (ft/ft)	Velocity (ft/sec)	Capacity (cfs)	Description
5.7	50	0.0200	0.15		Sheet Flow, Grass: Short n= 0.150 P2= 3.10"
1.7	101	0.0200	0.99		Shallow Concentrated Flow, Short Grass Pasture Kv= 7.0 fps
0.4	15	0.0133	0.58		Shallow Concentrated Flow, Woodland Kv= 5.0 fps
7.8	166	Total			

Subcatchment 100S: Area 100S

Hydrograph

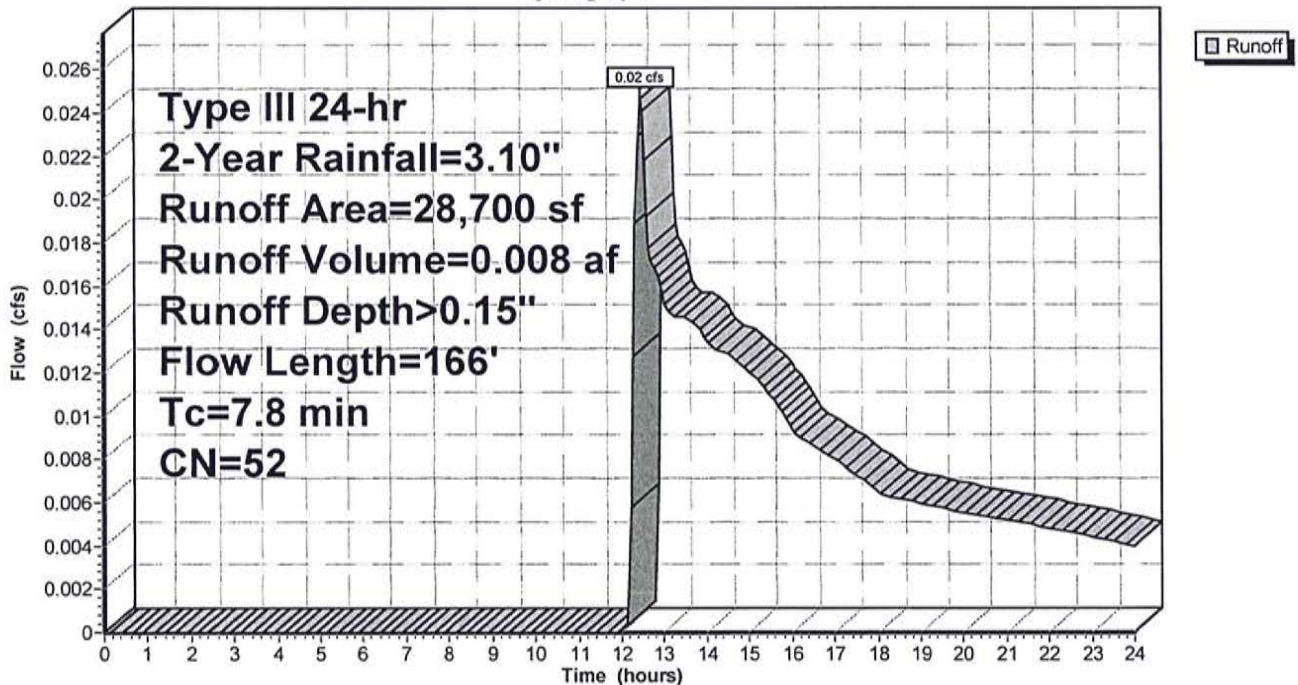

Summary for Subcatchment 200S: Area 200S

Runoff = 0.00 cfs @ 13.80 hrs, Volume= 0.001 af, Depth> 0.09"

Runoff by SCS TR-20 method, UH=SCS, Weighted-CN, Time Span= 0.00-24.00 hrs, dt= 0.05 hrs
Type III 24-hr 2-Year Rainfall=3.10"

Area (sf)	CN	Description
5,785	49	50-75% Grass cover, Fair, HSG A
5,785		100.00% Pervious Area

Tc (min)	Length (feet)	Slope (ft/ft)	Velocity (ft/sec)	Capacity (cfs)	Description
6.0					Direct Entry,

Subcatchment 200S: Area 200S

Hydrograph

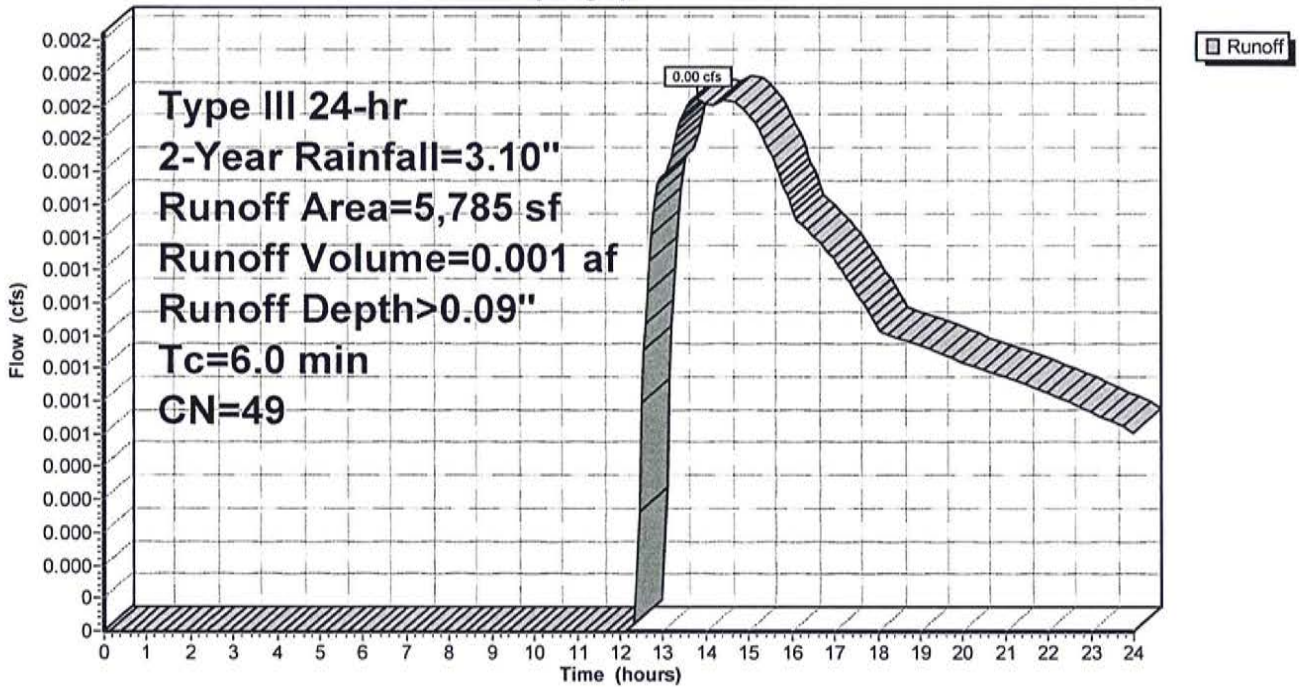

Summary for Subcatchment 300S: Area 300S

Runoff = 0.10 cfs @ 12.10 hrs, Volume= 0.008 af, Depth> 0.87"

Runoff by SCS TR-20 method, UH=SCS, Weighted-CN, Time Span= 0.00-24.00 hrs, dt= 0.05 hrs
 Type III 24-hr 2-Year Rainfall=3.10"

Area (sf)	CN	Description
2,635	49	50-75% Grass cover, Fair, HSG A
2,240	98	Paved parking, HSG A
4,875	72	Weighted Average
2,635		54.05% Pervious Area
2,240		45.95% Impervious Area

Tc (min)	Length (feet)	Slope (ft/ft)	Velocity (ft/sec)	Capacity (cfs)	Description
6.0					Direct Entry,

Subcatchment 300S: Area 300S

Hydrograph

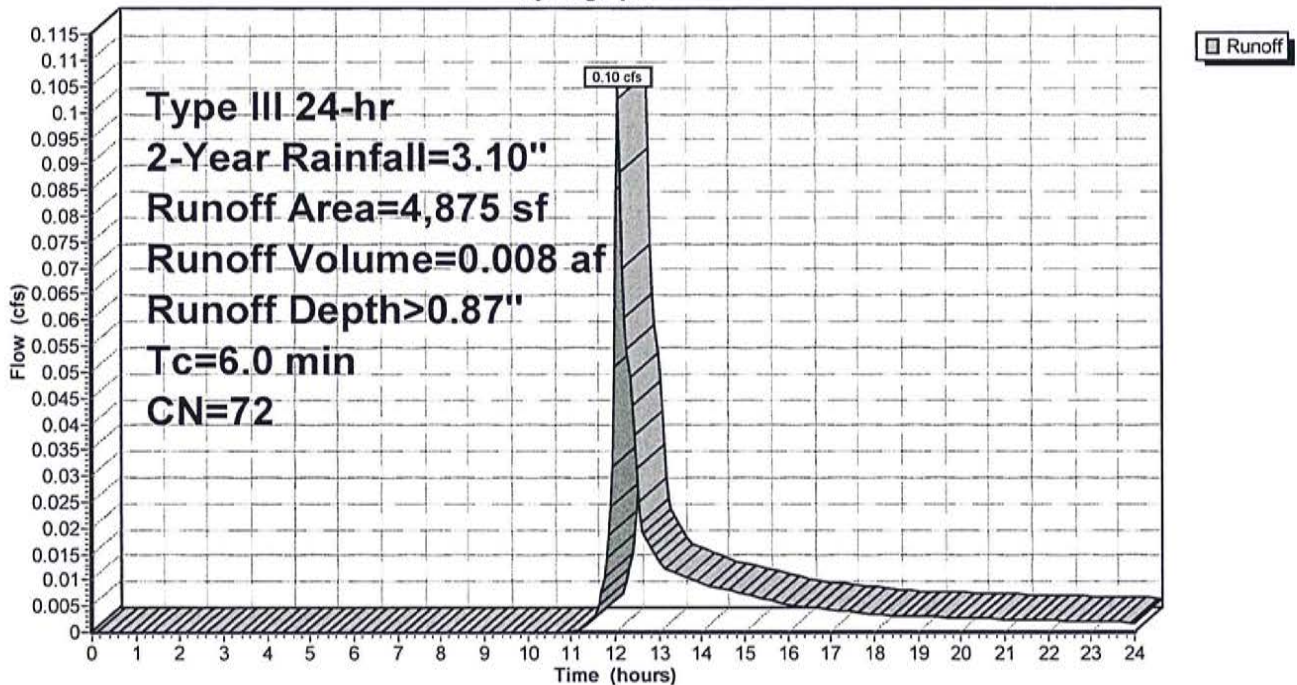

Summary for Link 100L: Pond

Inflow Area = 0.659 ac, 9.76% Impervious, Inflow Depth > 0.15" for 2-Year event
Inflow = 0.02 cfs @ 12.46 hrs, Volume= 0.008 af
Primary = 0.02 cfs @ 12.46 hrs, Volume= 0.008 af, Atten= 0%, Lag= 0.0 min

Primary outflow = Inflow, Time Span= 0.00-24.00 hrs, dt= 0.05 hrs

Link 100L: Pond

Hydrograph

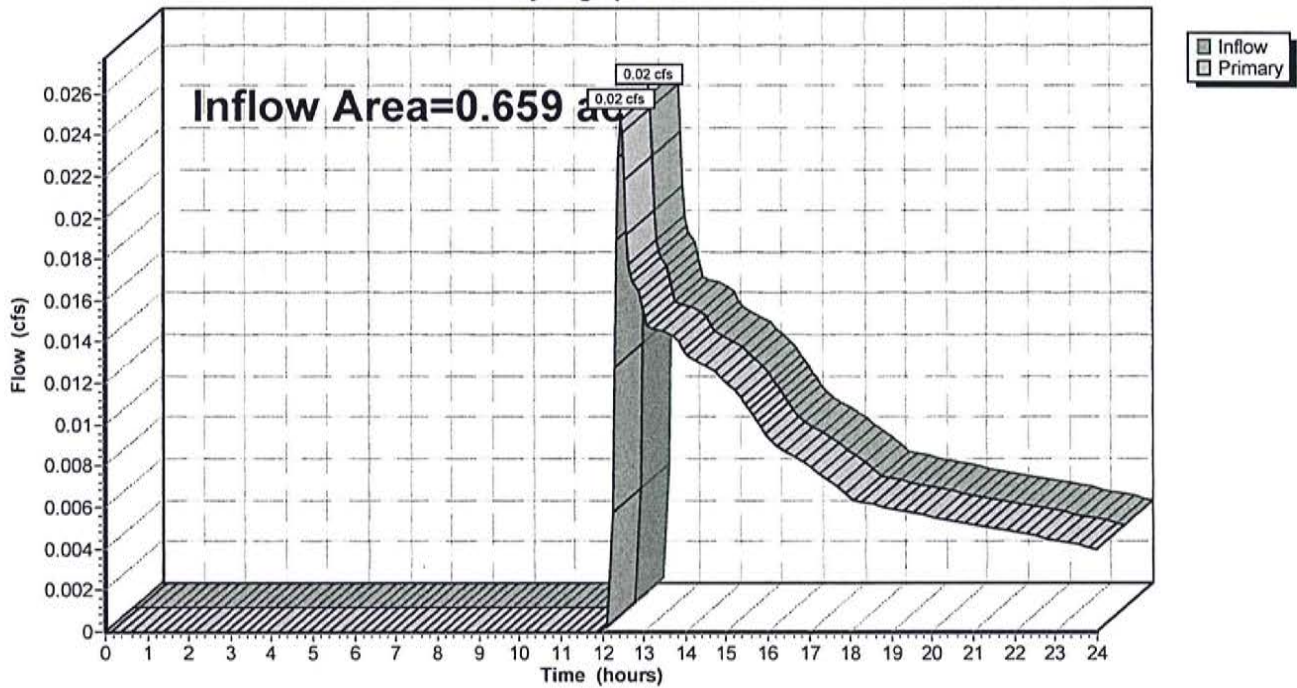

Summary for Link 200L: Wetlands

Inflow Area = 0.133 ac, 0.00% Impervious, Inflow Depth > 0.09" for 2-Year event
Inflow = 0.00 cfs @ 13.80 hrs, Volume= 0.001 af
Primary = 0.00 cfs @ 13.80 hrs, Volume= 0.001 af, Atten= 0%, Lag= 0.0 min

Primary outflow = Inflow, Time Span= 0.00-24.00 hrs, dt= 0.05 hrs

Link 200L: Wetlands

Hydrograph

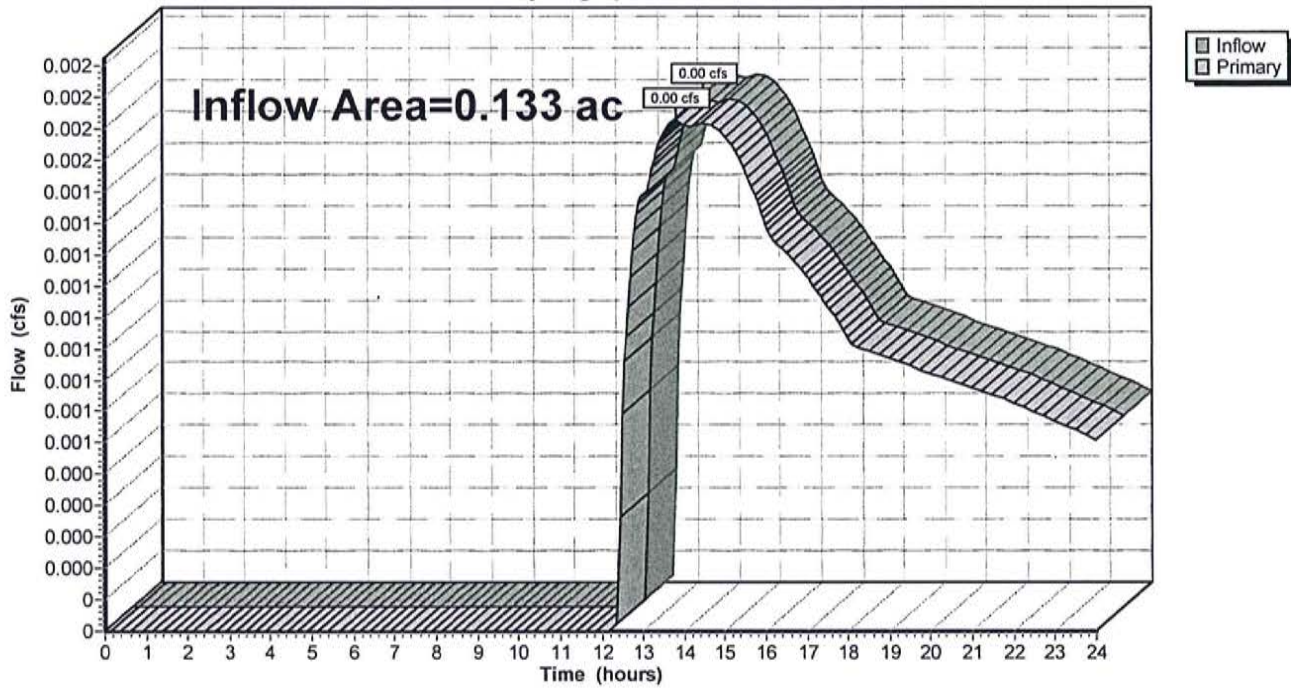

Summary for Link 300L: Route 1

Inflow Area = 0.112 ac, 45.95% Impervious, Inflow Depth > 0.87" for 2-Year event
Inflow = 0.10 cfs @ 12.10 hrs, Volume= 0.008 af
Primary = 0.10 cfs @ 12.10 hrs, Volume= 0.008 af, Atten= 0%, Lag= 0.0 min

Primary outflow = Inflow, Time Span= 0.00-24.00 hrs, dt= 0.05 hrs

Link 300L: Route 1

Hydrograph

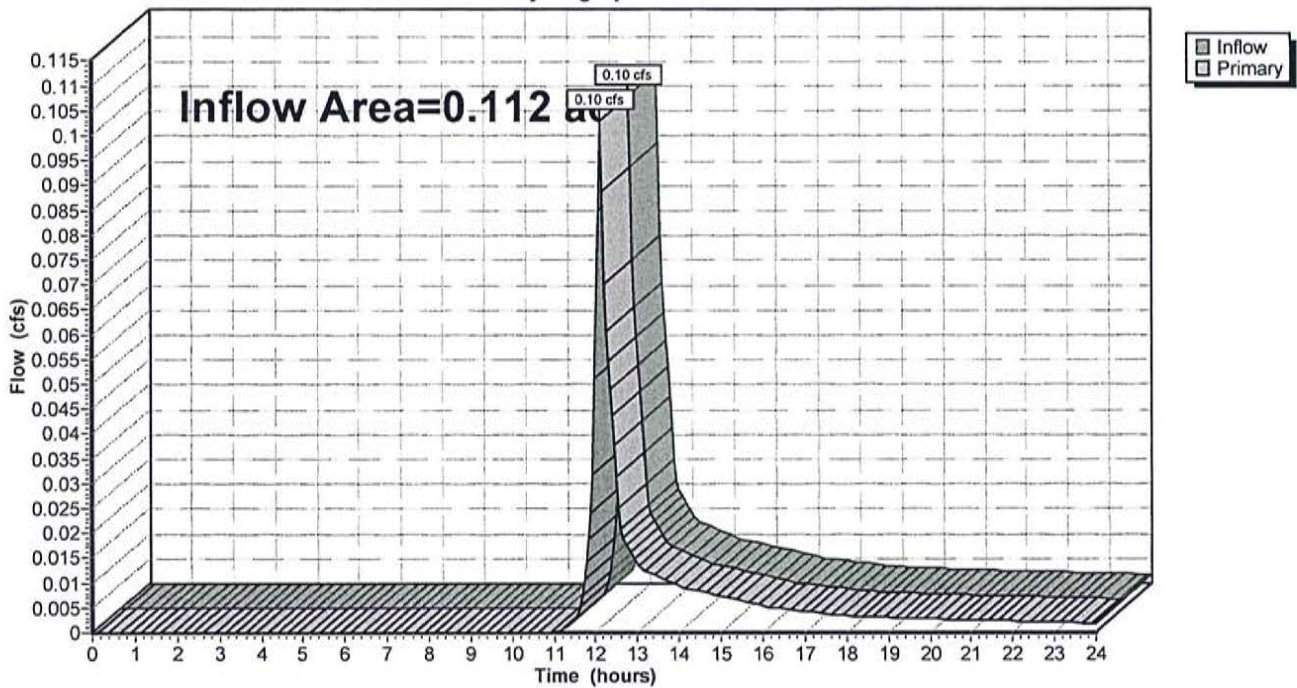

Pre-Dev

Type III 24-hr 10-Year Rainfall=4.50"

Prepared by Millennium Engineering, Inc.

Printed 8/27/2020

HydroCAD® 10.00-25 s/n 02736 © 2019 HydroCAD Software Solutions LLC

Page 12

Time span=0.00-24.00 hrs, dt=0.05 hrs, 481 points
Runoff by SCS TR-20 method, UH=SCS, Weighted-CN
Reach routing by Stor-Ind+Trans method - Pond routing by Stor-Ind method

Subcatchment 100S: Area 100S Runoff Area=28,700 sf 9.76% Impervious Runoff Depth>0.59"
Flow Length=166' Tc=7.8 min CN=52 Runoff=0.25 cfs 0.032 af

Subcatchment 200S: Area 200S Runoff Area=5,785 sf 0.00% Impervious Runoff Depth>0.46"
Tc=6.0 min CN=49 Runoff=0.03 cfs 0.005 af

Subcatchment 300S: Area 300S Runoff Area=4,875 sf 45.95% Impervious Runoff Depth>1.82"
Tc=6.0 min CN=72 Runoff=0.23 cfs 0.017 af

Link 100L: Pond Inflow=0.25 cfs 0.032 af
Primary=0.25 cfs 0.032 af

Link 200L: Wetlands Inflow=0.03 cfs 0.005 af
Primary=0.03 cfs 0.005 af

Link 300L: Route 1 Inflow=0.23 cfs 0.017 af
Primary=0.23 cfs 0.017 af

Total Runoff Area = 0.904 ac Runoff Volume = 0.054 af Average Runoff Depth = 0.72"
87.20% Pervious = 0.788 ac 12.80% Impervious = 0.116 ac

Summary for Subcatchment 100S: Area 100S

Runoff = 0.25 cfs @ 12.17 hrs, Volume= 0.032 af, Depth> 0.59"

Runoff by SCS TR-20 method, UH=SCS, Weighted-CN, Time Span= 0.00-24.00 hrs, dt= 0.05 hrs
Type III 24-hr 10-Year Rainfall=4.50"

Area (sf)	CN	Description
23,375	49	50-75% Grass cover, Fair, HSG A
2,525	30	Woods, Good, HSG A
2,800	98	Paved parking, HSG A
28,700	52	Weighted Average
25,900		90.24% Pervious Area
2,800		9.76% Impervious Area

Tc (min)	Length (feet)	Slope (ft/ft)	Velocity (ft/sec)	Capacity (cfs)	Description
5.7	50	0.0200	0.15		Sheet Flow, Grass: Short n= 0.150 P2= 3.10"
1.7	101	0.0200	0.99		Shallow Concentrated Flow, Short Grass Pasture Kv= 7.0 fps
0.4	15	0.0133	0.58		Shallow Concentrated Flow, Woodland Kv= 5.0 fps
7.8	166	Total			

Subcatchment 100S: Area 100S

Hydrograph

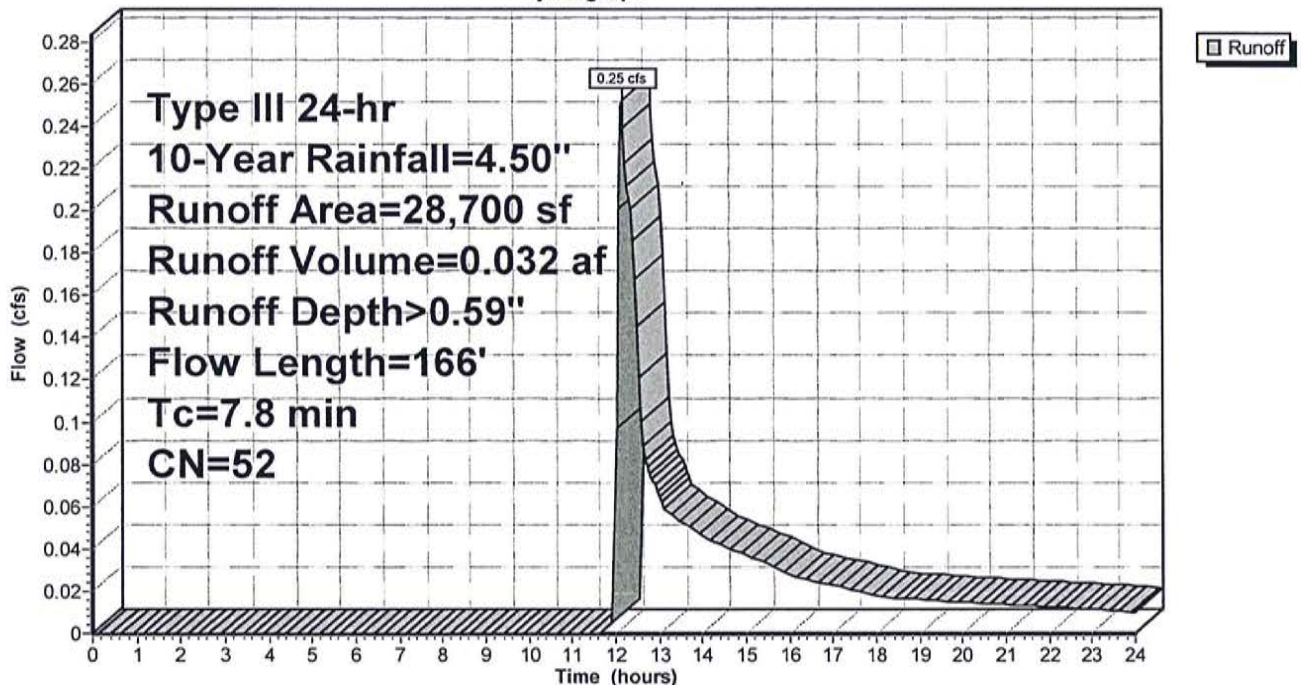

Summary for Subcatchment 200S: Area 200S

Runoff = 0.03 cfs @ 12.15 hrs, Volume= 0.005 af, Depth> 0.46"

Runoff by SCS TR-20 method, UH=SCS, Weighted-CN, Time Span= 0.00-24.00 hrs, dt= 0.05 hrs
Type III 24-hr 10-Year Rainfall=4.50"

Area (sf)	CN	Description
5,785	49	50-75% Grass cover, Fair, HSG A
5,785		100.00% Pervious Area

Tc (min)	Length (feet)	Slope (ft/ft)	Velocity (ft/sec)	Capacity (cfs)	Description
6.0					Direct Entry,

Subcatchment 200S: Area 200S

Hydrograph

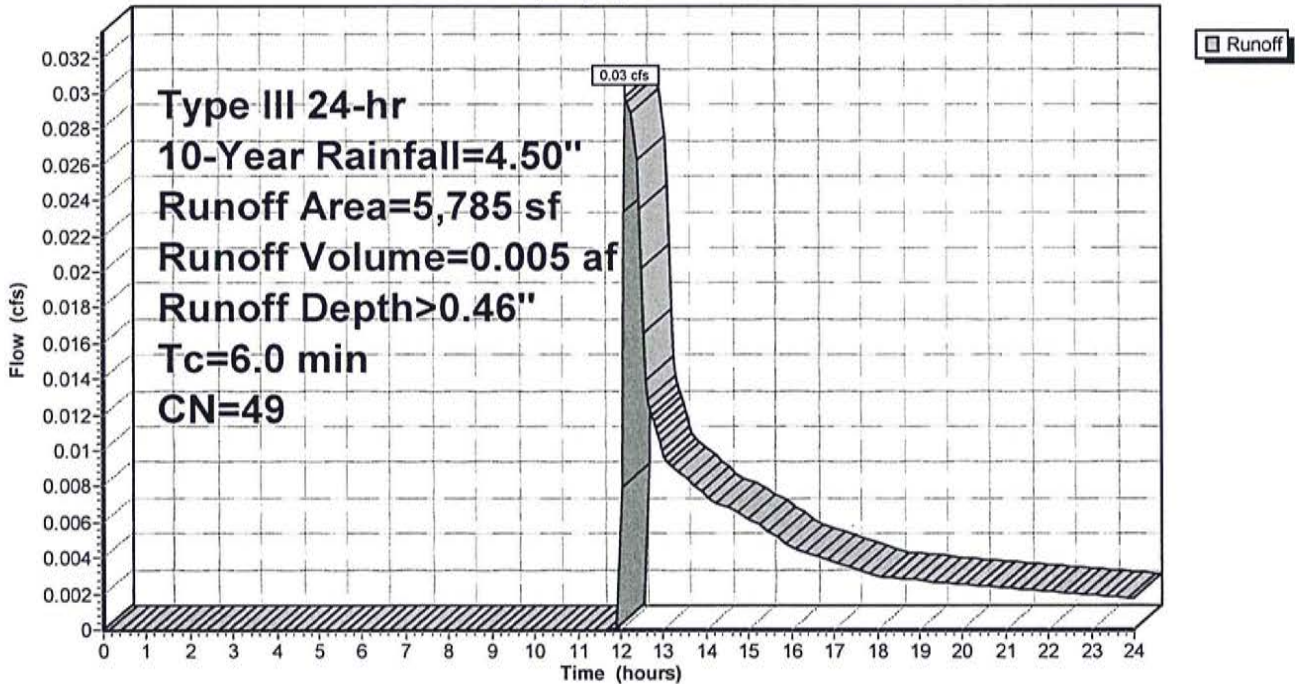

Summary for Subcatchment 300S: Area 300S

Runoff = 0.23 cfs @ 12.10 hrs, Volume= 0.017 af, Depth> 1.82"

Runoff by SCS TR-20 method, UH=SCS, Weighted-CN, Time Span= 0.00-24.00 hrs, dt= 0.05 hrs
 Type III 24-hr 10-Year Rainfall=4.50"

Area (sf)	CN	Description
2,635	49	50-75% Grass cover, Fair, HSG A
2,240	98	Paved parking, HSG A
4,875	72	Weighted Average
2,635		54.05% Pervious Area
2,240		45.95% Impervious Area

Tc (min)	Length (feet)	Slope (ft/ft)	Velocity (ft/sec)	Capacity (cfs)	Description
6.0					Direct Entry,

Subcatchment 300S: Area 300S

Hydrograph

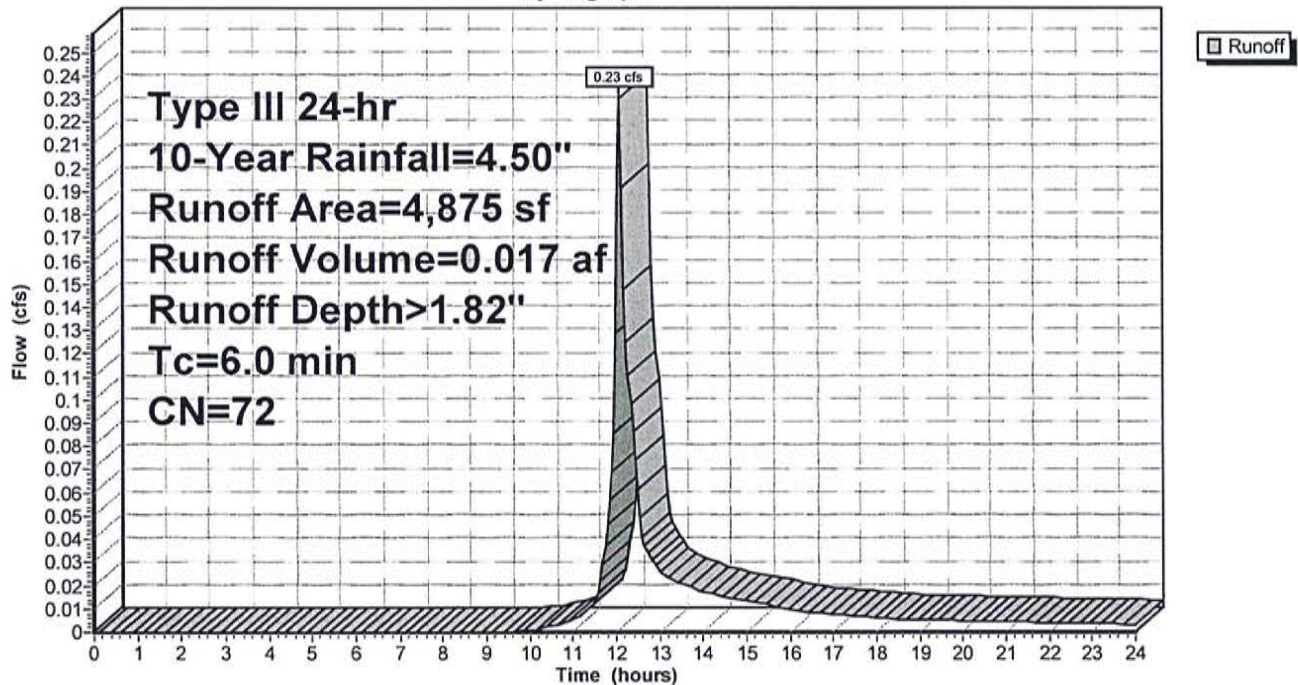

Summary for Link 100L: Pond

Inflow Area = 0.659 ac, 9.76% Impervious, Inflow Depth > 0.59" for 10-Year event
Inflow = 0.25 cfs @ 12.17 hrs, Volume= 0.032 af
Primary = 0.25 cfs @ 12.17 hrs, Volume= 0.032 af, Atten= 0%, Lag= 0.0 min

Primary outflow = Inflow, Time Span= 0.00-24.00 hrs, dt= 0.05 hrs

Link 100L: Pond

Hydrograph

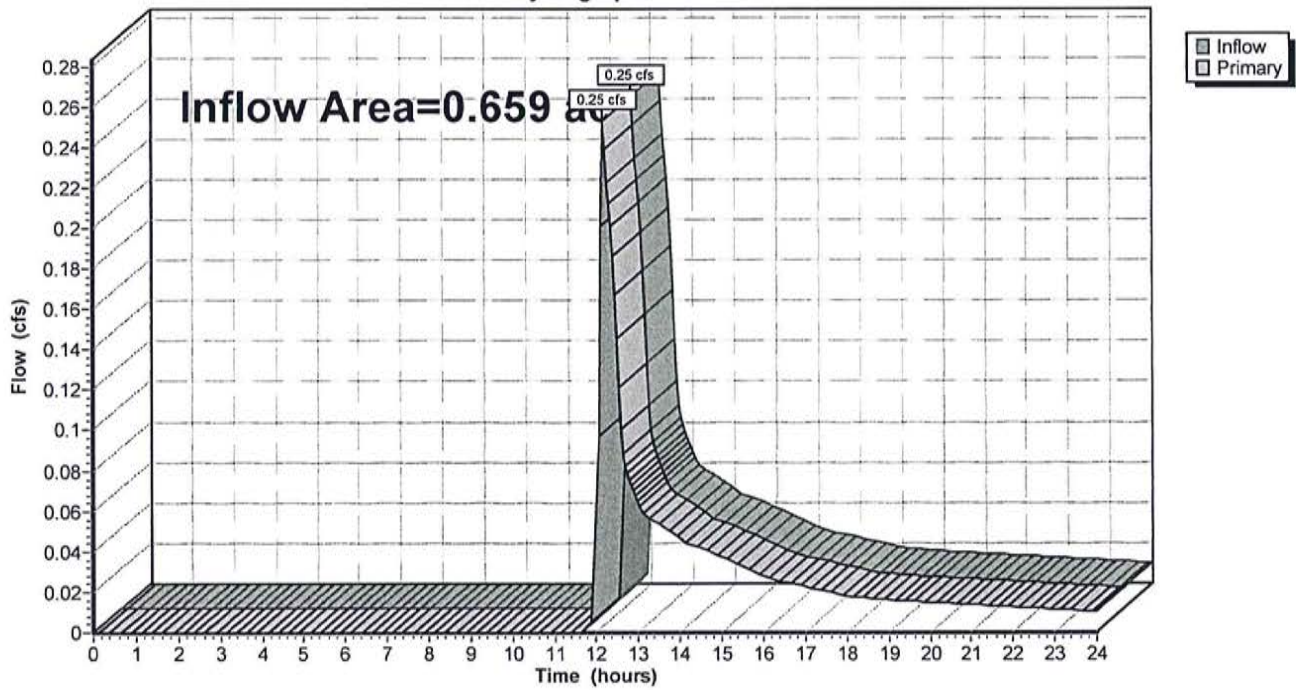

Summary for Link 200L: Wetlands

Inflow Area = 0.133 ac, 0.00% Impervious, Inflow Depth > 0.46" for 10-Year event
Inflow = 0.03 cfs @ 12.15 hrs, Volume= 0.005 af
Primary = 0.03 cfs @ 12.15 hrs, Volume= 0.005 af, Atten= 0%, Lag= 0.0 min

Primary outflow = Inflow, Time Span= 0.00-24.00 hrs, dt= 0.05 hrs

Link 200L: Wetlands

Hydrograph

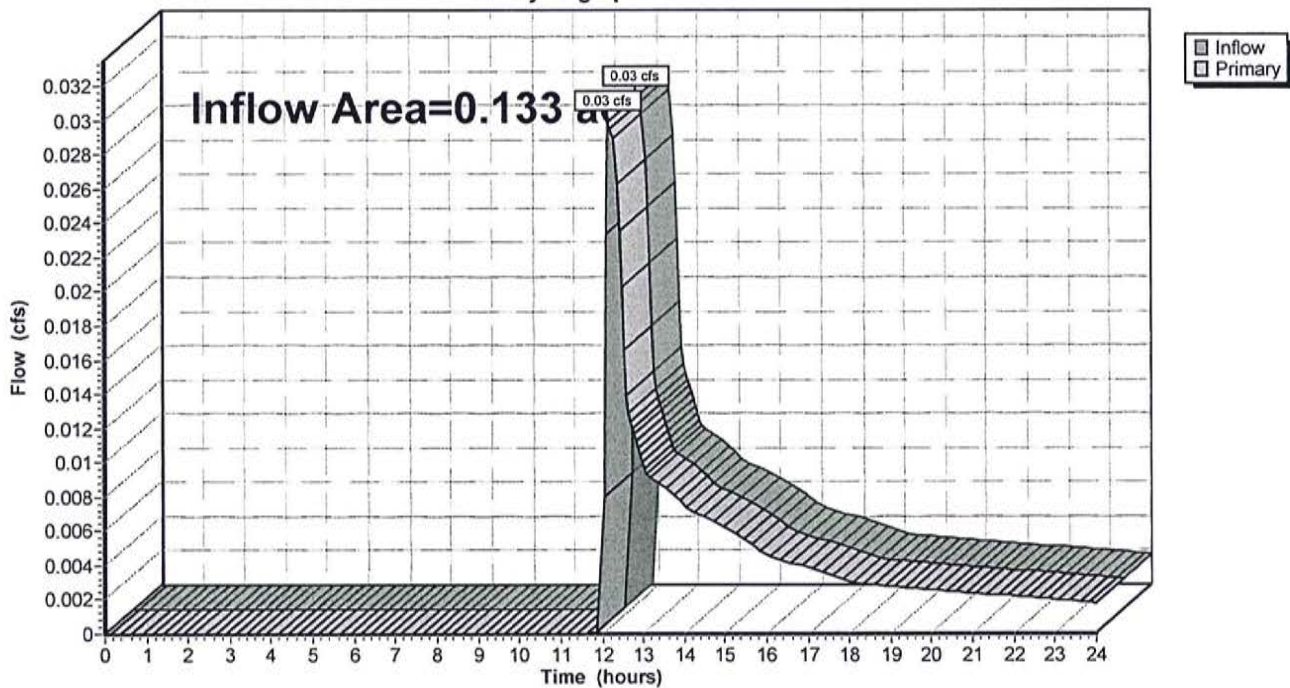

Summary for Link 300L: Route 1

Inflow Area = 0.112 ac, 45.95% Impervious, Inflow Depth > 1.82" for 10-Year event
Inflow = 0.23 cfs @ 12.10 hrs, Volume= 0.017 af
Primary = 0.23 cfs @ 12.10 hrs, Volume= 0.017 af, Atten= 0%, Lag= 0.0 min

Primary outflow = Inflow, Time Span= 0.00-24.00 hrs, dt= 0.05 hrs

Link 300L: Route 1

Hydrograph

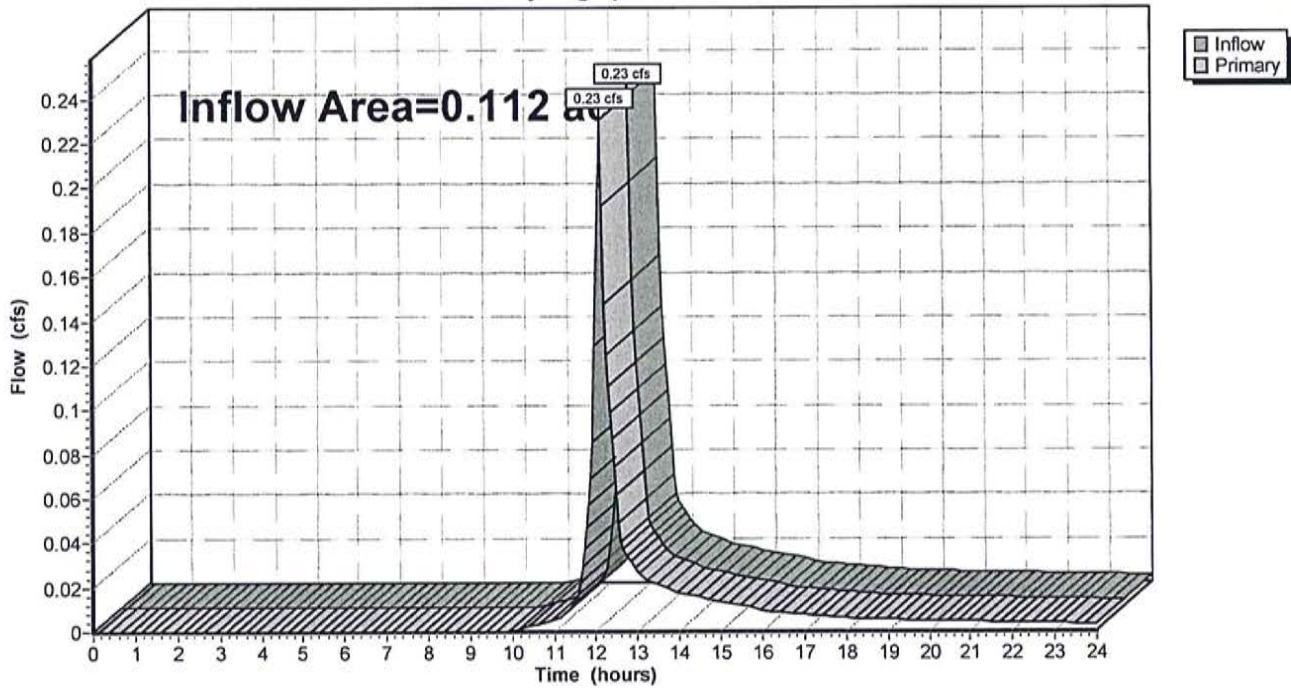

Pre-Dev

Type III 24-hr 100-Year Rainfall=6.50"

Prepared by Millennium Engineering, Inc.

Printed 8/27/2020

HydroCAD® 10.00-25 s/n 02736 © 2019 HydroCAD Software Solutions LLC

Page 19

Time span=0.00-24.00 hrs, dt=0.05 hrs, 481 points
Runoff by SCS TR-20 method, UH=SCS, Weighted-CN
Reach routing by Stor-Ind+Trans method - Pond routing by Stor-Ind method

Subcatchment 100S: Area 100S	Runoff Area=28,700 sf 9.76% Impervious Runoff Depth>1.56" Flow Length=166' Tc=7.8 min CN=52 Runoff=0.96 cfs 0.085 af
Subcatchment 200S: Area 200S	Runoff Area=5,785 sf 0.00% Impervious Runoff Depth>1.31" Tc=6.0 min CN=49 Runoff=0.16 cfs 0.015 af
Subcatchment 300S: Area 300S	Runoff Area=4,875 sf 45.95% Impervious Runoff Depth>3.40" Tc=6.0 min CN=72 Runoff=0.44 cfs 0.032 af
Link 100L: Pond	Inflow=0.96 cfs 0.085 af Primary=0.96 cfs 0.085 af
Link 200L: Wetlands	Inflow=0.16 cfs 0.015 af Primary=0.16 cfs 0.015 af
Link 300L: Route 1	Inflow=0.44 cfs 0.032 af Primary=0.44 cfs 0.032 af

Total Runoff Area = 0.904 ac Runoff Volume = 0.132 af Average Runoff Depth = 1.75"
87.20% Pervious = 0.788 ac 12.80% Impervious = 0.116 ac

Summary for Subcatchment 100S: Area 100S

Runoff = 0.96 cfs @ 12.13 hrs, Volume= 0.085 af, Depth> 1.56"

Runoff by SCS TR-20 method, UH=SCS, Weighted-CN, Time Span= 0.00-24.00 hrs, dt= 0.05 hrs
 Type III 24-hr 100-Year Rainfall=6.50"

Area (sf)	CN	Description
23,375	49	50-75% Grass cover, Fair, HSG A
2,525	30	Woods, Good, HSG A
2,800	98	Paved parking, HSG A
28,700	52	Weighted Average
25,900		90.24% Pervious Area
2,800		9.76% Impervious Area

Tc (min)	Length (feet)	Slope (ft/ft)	Velocity (ft/sec)	Capacity (cfs)	Description
5.7	50	0.0200	0.15		Sheet Flow, Grass: Short n= 0.150 P2= 3.10"
1.7	101	0.0200	0.99		Shallow Concentrated Flow, Short Grass Pasture Kv= 7.0 fps
0.4	15	0.0133	0.58		Shallow Concentrated Flow, Woodland Kv= 5.0 fps
7.8	166	Total			

Subcatchment 100S: Area 100S

Hydrograph

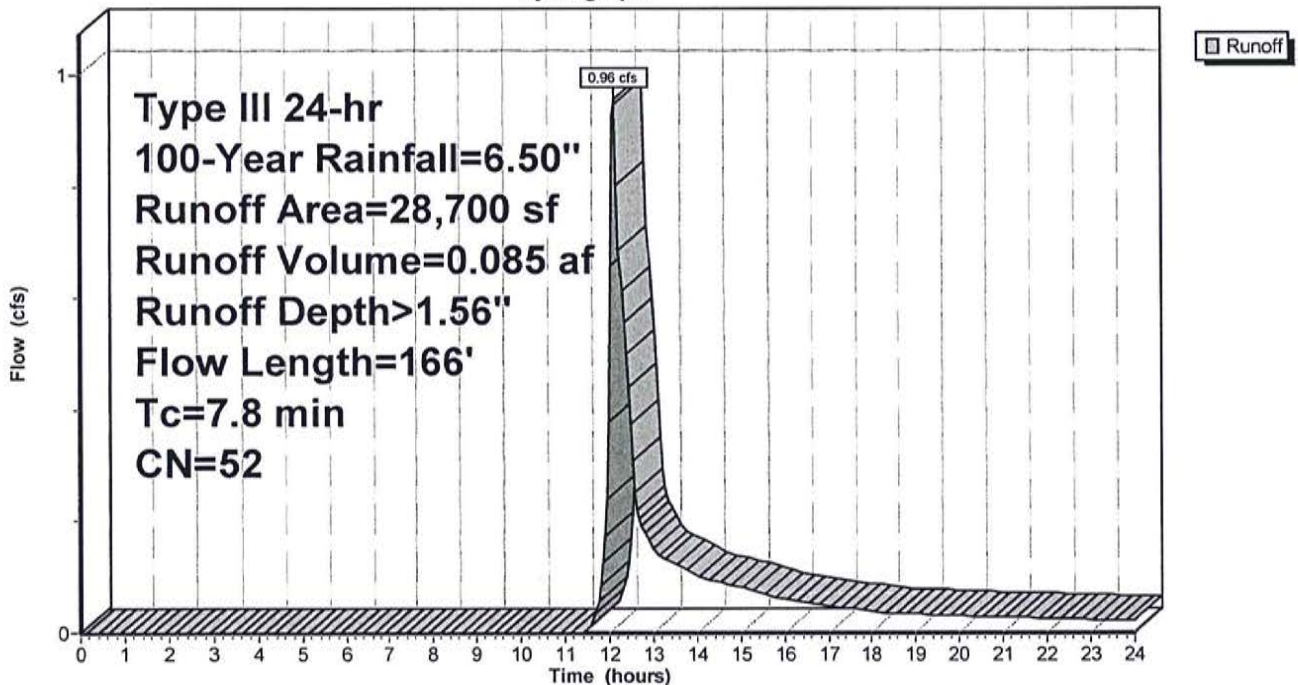

Summary for Subcatchment 200S: Area 200S

Runoff = 0.16 cfs @ 12.11 hrs, Volume= 0.015 af, Depth> 1.31"

Runoff by SCS TR-20 method, UH=SCS, Weighted-CN, Time Span= 0.00-24.00 hrs, dt= 0.05 hrs
Type III 24-hr 100-Year Rainfall=6.50"

Area (sf)	CN	Description
5,785	49	50-75% Grass cover, Fair, HSG A
5,785		100.00% Pervious Area

Tc (min)	Length (feet)	Slope (ft/ft)	Velocity (ft/sec)	Capacity (cfs)	Description
6.0					Direct Entry,

Subcatchment 200S: Area 200S

Hydrograph

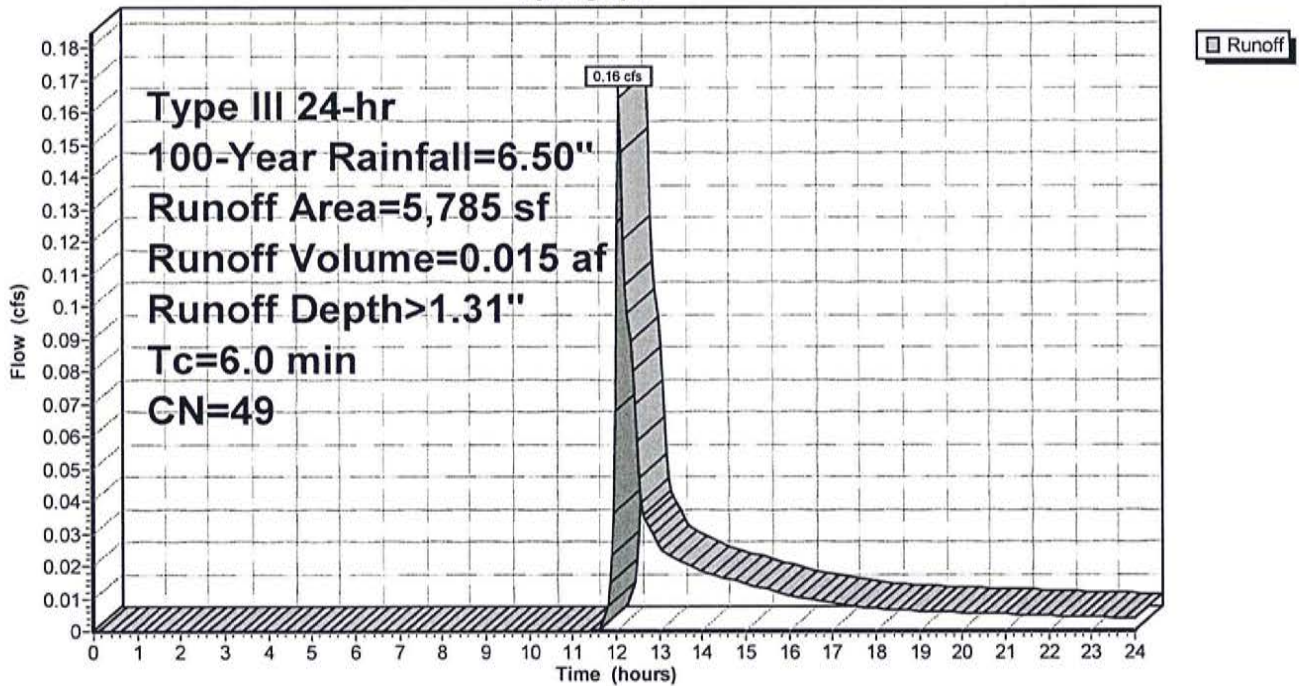

Summary for Subcatchment 300S: Area 300S

Runoff = 0.44 cfs @ 12.09 hrs, Volume= 0.032 af, Depth> 3.40"

Runoff by SCS TR-20 method, UH=SCS, Weighted-CN, Time Span= 0.00-24.00 hrs, dt= 0.05 hrs
 Type III 24-hr 100-Year Rainfall=6.50"

Area (sf)	CN	Description
2,635	49	50-75% Grass cover, Fair, HSG A
2,240	98	Paved parking, HSG A
4,875	72	Weighted Average
2,635		54.05% Pervious Area
2,240		45.95% Impervious Area

Tc (min)	Length (feet)	Slope (ft/ft)	Velocity (ft/sec)	Capacity (cfs)	Description
6.0					Direct Entry,

Subcatchment 300S: Area 300S

Hydrograph

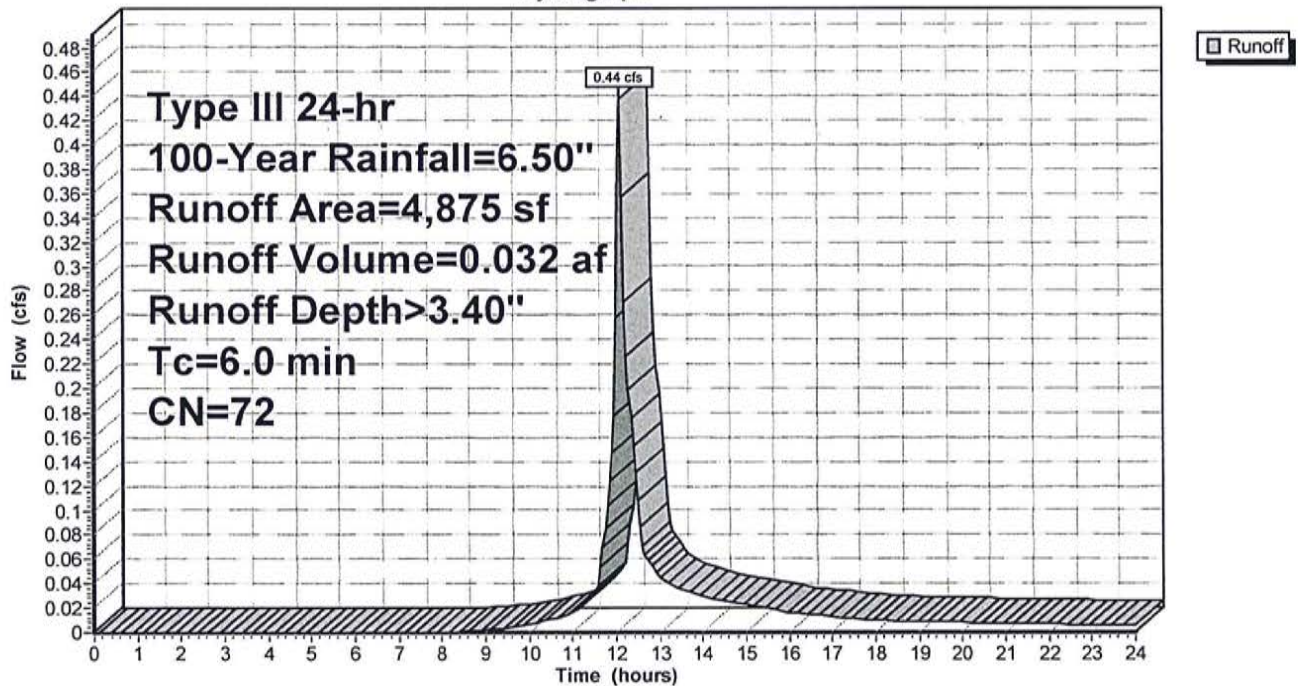

Summary for Link 100L: Pond

Inflow Area = 0.659 ac, 9.76% Impervious, Inflow Depth > 1.56" for 100-Year event
Inflow = 0.96 cfs @ 12.13 hrs, Volume= 0.085 af
Primary = 0.96 cfs @ 12.13 hrs, Volume= 0.085 af, Atten= 0%, Lag= 0.0 min

Primary outflow = Inflow, Time Span= 0.00-24.00 hrs, dt= 0.05 hrs

Link 100L: Pond

Hydrograph

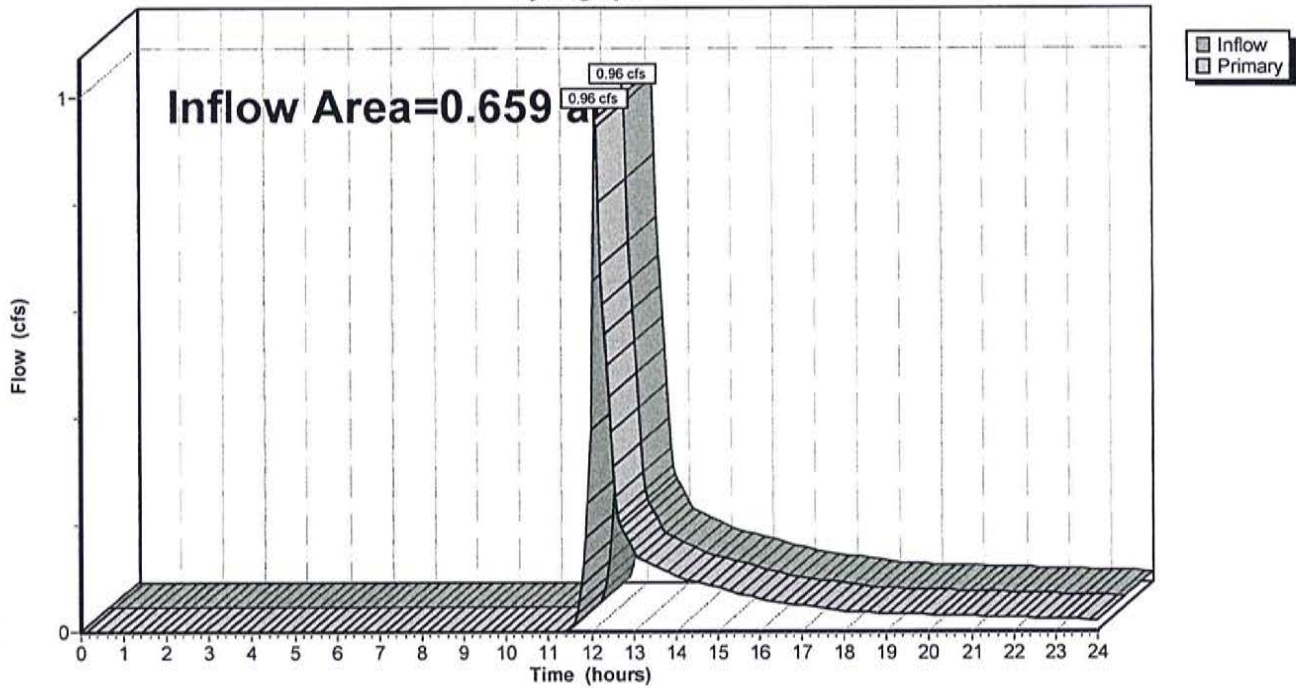

Summary for Link 200L: Wetlands

Inflow Area = 0.133 ac, 0.00% Impervious, Inflow Depth > 1.31" for 100-Year event
Inflow = 0.16 cfs @ 12.11 hrs, Volume= 0.015 af
Primary = 0.16 cfs @ 12.11 hrs, Volume= 0.015 af, Atten= 0%, Lag= 0.0 min

Primary outflow = Inflow, Time Span= 0.00-24.00 hrs, dt= 0.05 hrs

Link 200L: Wetlands

Hydrograph

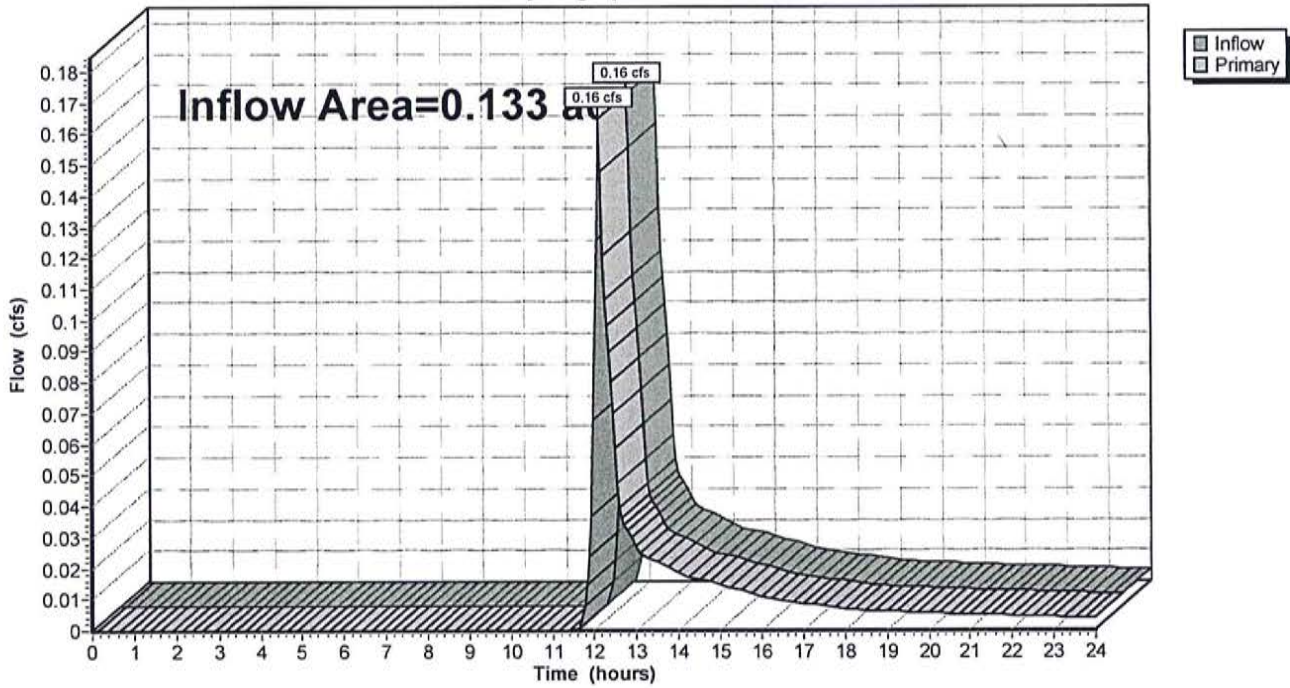

Summary for Link 300L: Route 1

Inflow Area = 0.112 ac, 45.95% Impervious, Inflow Depth > 3.40" for 100-Year event
Inflow = 0.44 cfs @ 12.09 hrs, Volume= 0.032 af
Primary = 0.44 cfs @ 12.09 hrs, Volume= 0.032 af, Atten= 0%, Lag= 0.0 min

Primary outflow = Inflow, Time Span= 0.00-24.00 hrs, dt= 0.05 hrs

Link 300L: Route 1

Hydrograph

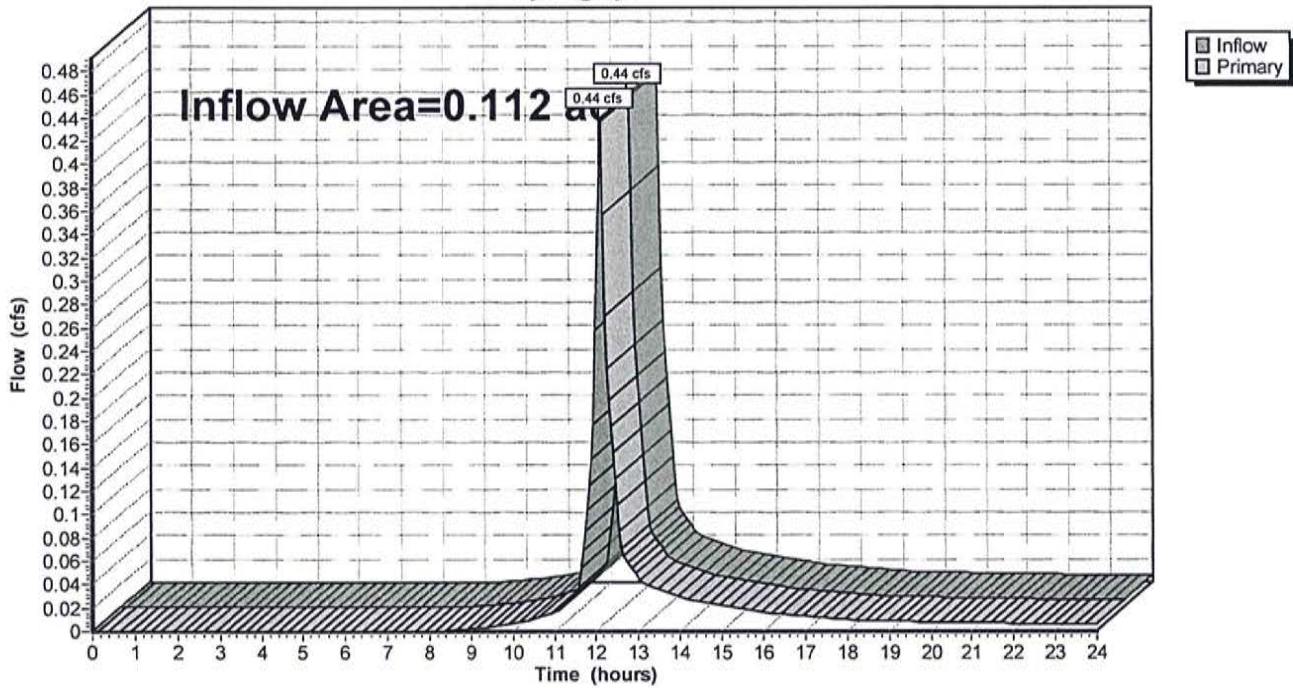

11.0 APPENDIX D – POST-DEVELOPMENT DRAINAGE CALCULATIONS

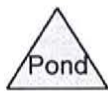
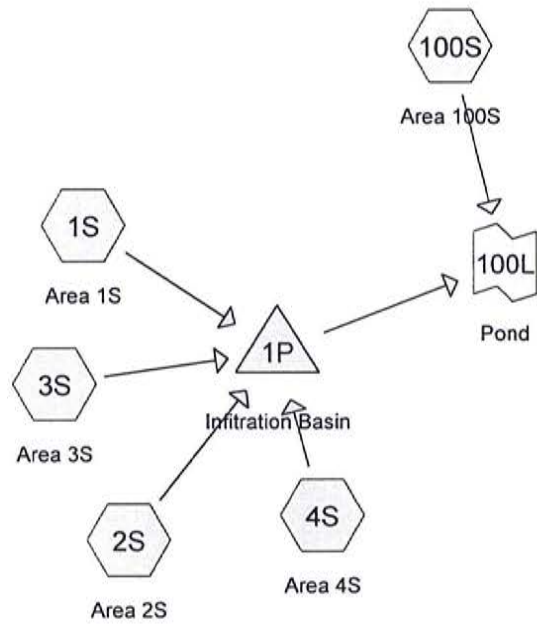
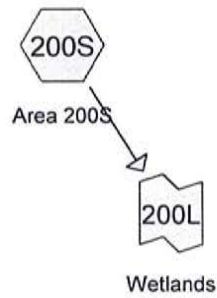
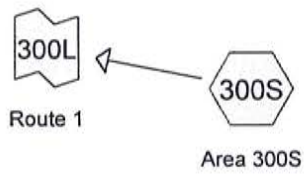

Post-Dev

Area Listing (all nodes)

Area (sq-ft)	CN	Description (subcatchment-numbers)
18,415	39	>75% Grass cover, Good, HSG A (1S, 2S, 4S, 100S, 200S, 300S)
17,625	98	Paved parking, HSG A (1S, 2S, 300S)
3,000	98	Roofs, HSG A (3S)
600	30	Woods, Good, HSG A (100S)
39,640	70	TOTAL AREA

Post-Dev

Soil Listing (all nodes)

Area (sq-ft)	Soil Group	Subcatchment Numbers
39,640	HSG A	1S, 2S, 3S, 4S, 100S, 200S, 300S
0	HSG B	
0	HSG C	
0	HSG D	
0	Other	
39,640		TOTAL AREA

Post-Dev

Ground Covers (all nodes)

HSG-A (sq-ft)	HSG-B (sq-ft)	HSG-C (sq-ft)	HSG-D (sq-ft)	Other (sq-ft)	Total (sq-ft)	Ground Cover
18,415	0	0	0	0	18,415	>75% Grass cover, Good
17,625	0	0	0	0	17,625	Paved parking
3,000	0	0	0	0	3,000	Roofs
600	0	0	0	0	600	Woods, Good
39,640	0	0	0	0	39,640	TOTAL AREA

Post-Dev

Type III 24-hr 2-Year Rainfall=3.10"

Prepared by Millennium Engineering, Inc.

Printed 8/27/2020

HydroCAD® 10.00-25 s/n 02736 © 2019 HydroCAD Software Solutions LLC

Page 5

Time span=5.00-20.00 hrs, dt=0.05 hrs, 301 points
Runoff by SCS TR-20 method, UH=SCS, Weighted-CN
Reach routing by Stor-Ind+Trans method - Pond routing by Stor-Ind method

Subcatchment 1S: Area 1S	Runoff Area=11,350 sf 93.83% Impervious Runoff Depth>2.31" Tc=6.0 min CN=94 Runoff=0.70 cfs 2,187 cf
Subcatchment 2S: Area 2S	Runoff Area=7,000 sf 94.64% Impervious Runoff Depth>2.41" Tc=0.0 min CN=95 Runoff=0.52 cfs 1,406 cf
Subcatchment 3S: Area 3S	Runoff Area=3,000 sf 100.00% Impervious Runoff Depth>2.68" Tc=6.0 min CN=98 Runoff=0.20 cfs 670 cf
Subcatchment 4S: Area 4S	Runoff Area=6,250 sf 0.00% Impervious Runoff Depth=0.00" Tc=6.0 min CN=39 Runoff=0.00 cfs 0 cf
Subcatchment 100S: Area 100S	Runoff Area=7,745 sf 0.00% Impervious Runoff Depth=0.00" Tc=6.0 min CN=38 Runoff=0.00 cfs 0 cf
Subcatchment 200S: Area 200S	Runoff Area=3,335 sf 0.00% Impervious Runoff Depth=0.00" Tc=6.0 min CN=39 Runoff=0.00 cfs 0 cf
Subcatchment 300S: Area 300S	Runoff Area=960 sf 36.46% Impervious Runoff Depth>0.35" Tc=6.0 min CN=61 Runoff=0.01 cfs 28 cf
Pond 1P: Infiltration Basin	Peak Elev=18.53' Storage=1,442 cf Inflow=1.23 cfs 4,263 cf Discarded=0.21 cfs 4,258 cf Primary=0.00 cfs 0 cf Outflow=0.21 cfs 4,258 cf
Link 100L: Pond	Inflow=0.00 cfs 0 cf Primary=0.00 cfs 0 cf
Link 200L: Wetlands	Inflow=0.00 cfs 0 cf Primary=0.00 cfs 0 cf
Link 300L: Route 1	Inflow=0.01 cfs 28 cf Primary=0.01 cfs 28 cf

Total Runoff Area = 39,640 sf Runoff Volume = 4,292 cf Average Runoff Depth = 1.30"
47.97% Pervious = 19,015 sf 52.03% Impervious = 20,625 sf

Post-Dev

Prepared by Millennium Engineering, Inc.
 HydroCAD® 10.00-25 s/n 02736 © 2019 HydroCAD Software Solutions LLC

Type III 24-hr 2-Year Rainfall=3.10"

Printed 8/27/2020

Page 6

Summary for Subcatchment 1S: Area 1S

Runoff = 0.70 cfs @ 12.09 hrs, Volume= 2,187 cf, Depth> 2.31"

Runoff by SCS TR-20 method, UH=SCS, Weighted-CN, Time Span= 5.00-20.00 hrs, dt= 0.05 hrs
 Type III 24-hr 2-Year Rainfall=3.10"

Area (sf)	CN	Description
10,650	98	Paved parking, HSG A
700	39	>75% Grass cover, Good, HSG A
11,350	94	Weighted Average
700		6.17% Pervious Area
10,650		93.83% Impervious Area

Tc (min)	Length (feet)	Slope (ft/ft)	Velocity (ft/sec)	Capacity (cfs)	Description
6.0					Direct Entry,

Subcatchment 1S: Area 1S

Hydrograph

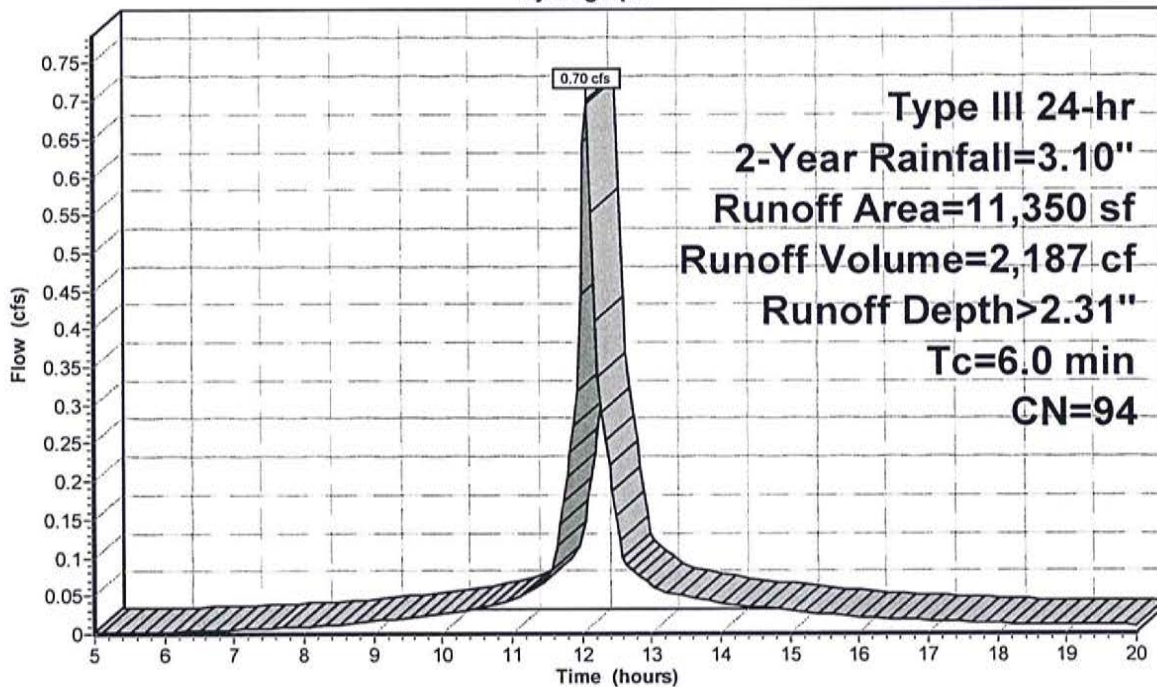

Runoff

Post-Dev

Prepared by Millennium Engineering, Inc.
HydroCAD® 10.00-25 s/n 02736 © 2019 HydroCAD Software Solutions LLC

Type III 24-hr 2-Year Rainfall=3.10"

Printed 8/27/2020

Page 7

Summary for Subcatchment 2S: Area 2S

Runoff = 0.52 cfs @ 12.00 hrs, Volume= 1,406 cf, Depth> 2.41"

Runoff by SCS TR-20 method, UH=SCS, Weighted-CN, Time Span= 5.00-20.00 hrs, dt= 0.05 hrs
Type III 24-hr 2-Year Rainfall=3.10"

Area (sf)	CN	Description
6,625	98	Paved parking, HSG A
375	39	>75% Grass cover, Good, HSG A
7,000	95	Weighted Average
375		5.36% Pervious Area
6,625		94.64% Impervious Area

Subcatchment 2S: Area 2S

Hydrograph

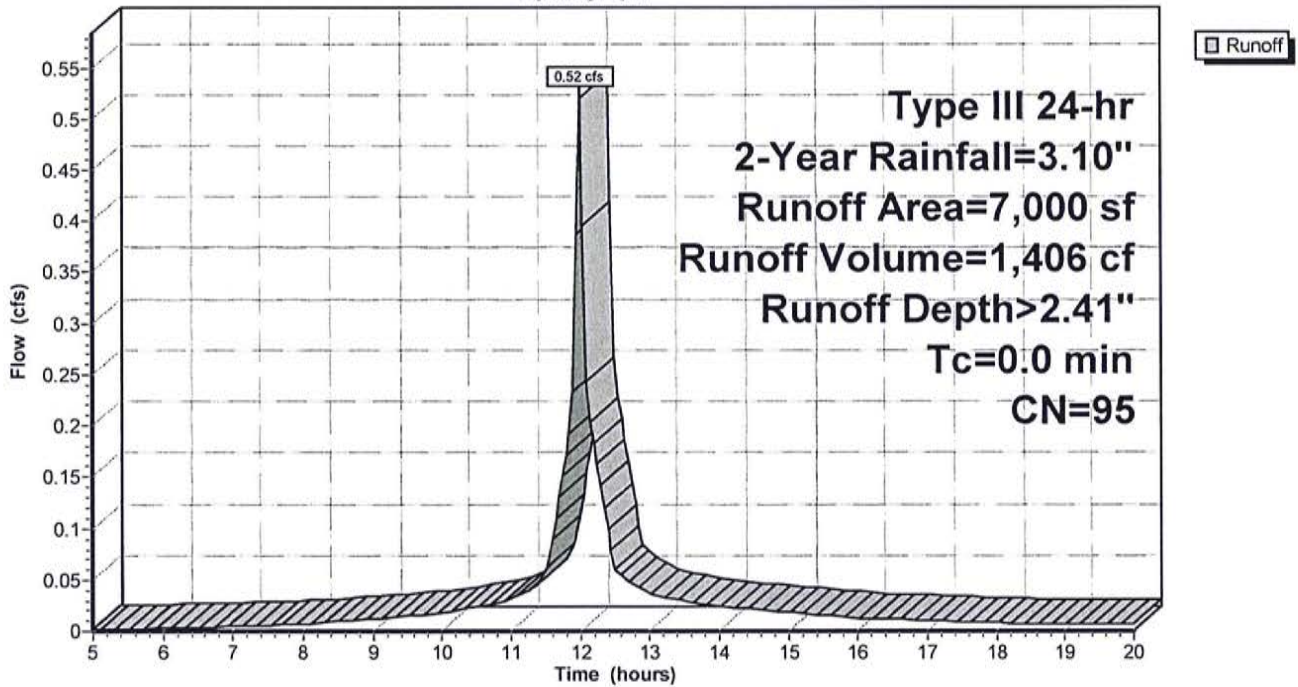

Post-Dev

Prepared by Millennium Engineering, Inc.
HydroCAD® 10.00-25 s/n 02736 © 2019 HydroCAD Software Solutions LLC

Type III 24-hr 2-Year Rainfall=3.10"

Printed 8/27/2020

Page 8

Summary for Subcatchment 3S: Area 3S

Runoff = 0.20 cfs @ 12.09 hrs, Volume= 670 cf, Depth> 2.68"

Runoff by SCS TR-20 method, UH=SCS, Weighted-CN, Time Span= 5.00-20.00 hrs, dt= 0.05 hrs
Type III 24-hr 2-Year Rainfall=3.10"

Area (sf)	CN	Description
3,000	98	Roofs, HSG A
3,000		100.00% Impervious Area

Tc (min)	Length (feet)	Slope (ft/ft)	Velocity (ft/sec)	Capacity (cfs)	Description
6.0					Direct Entry,

Subcatchment 3S: Area 3S

Hydrograph

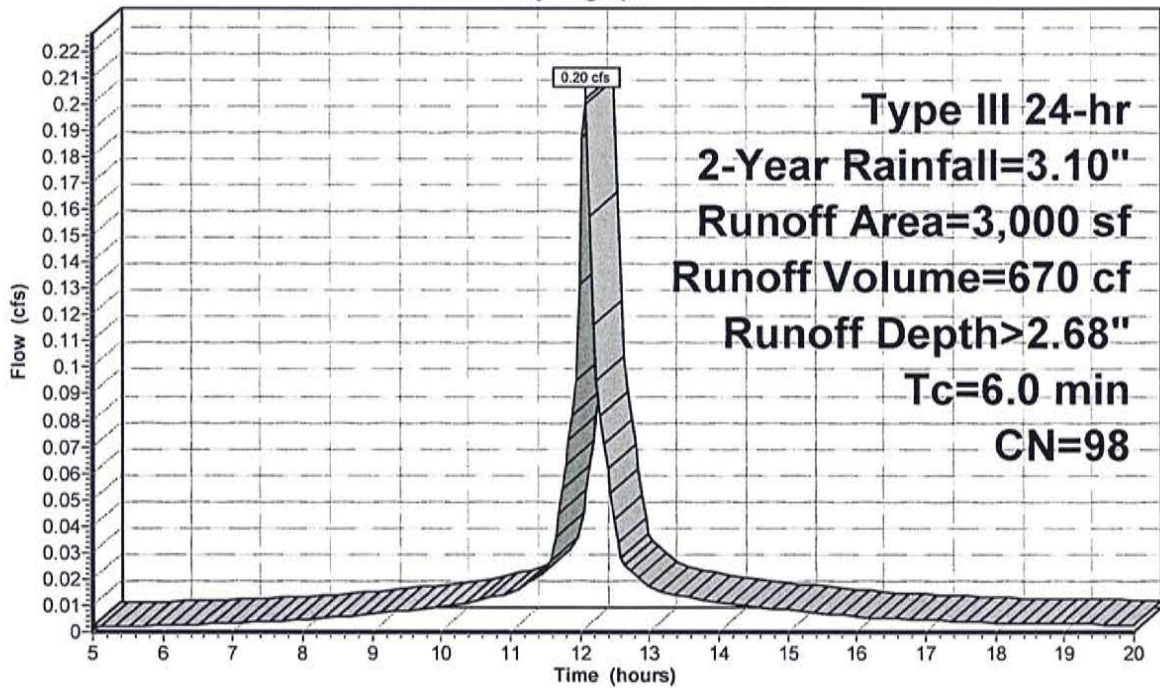

Post-Dev

Prepared by Millennium Engineering, Inc.
HydroCAD® 10.00-25 s/n 02736 © 2019 HydroCAD Software Solutions LLC

Type III 24-hr 2-Year Rainfall=3.10"

Printed 8/27/2020

Page 9

Summary for Subcatchment 4S: Area 4S

Runoff = 0.00 cfs @ 5.00 hrs, Volume= 0 cf, Depth= 0.00"

Runoff by SCS TR-20 method, UH=SCS, Weighted-CN, Time Span= 5.00-20.00 hrs, dt= 0.05 hrs
Type III 24-hr 2-Year Rainfall=3.10"

Area (sf)	CN	Description
6,250	39	>75% Grass cover, Good, HSG A
6,250		100.00% Pervious Area

Tc (min)	Length (feet)	Slope (ft/ft)	Velocity (ft/sec)	Capacity (cfs)	Description
6.0					Direct Entry,

Subcatchment 4S: Area 4S

Hydrograph

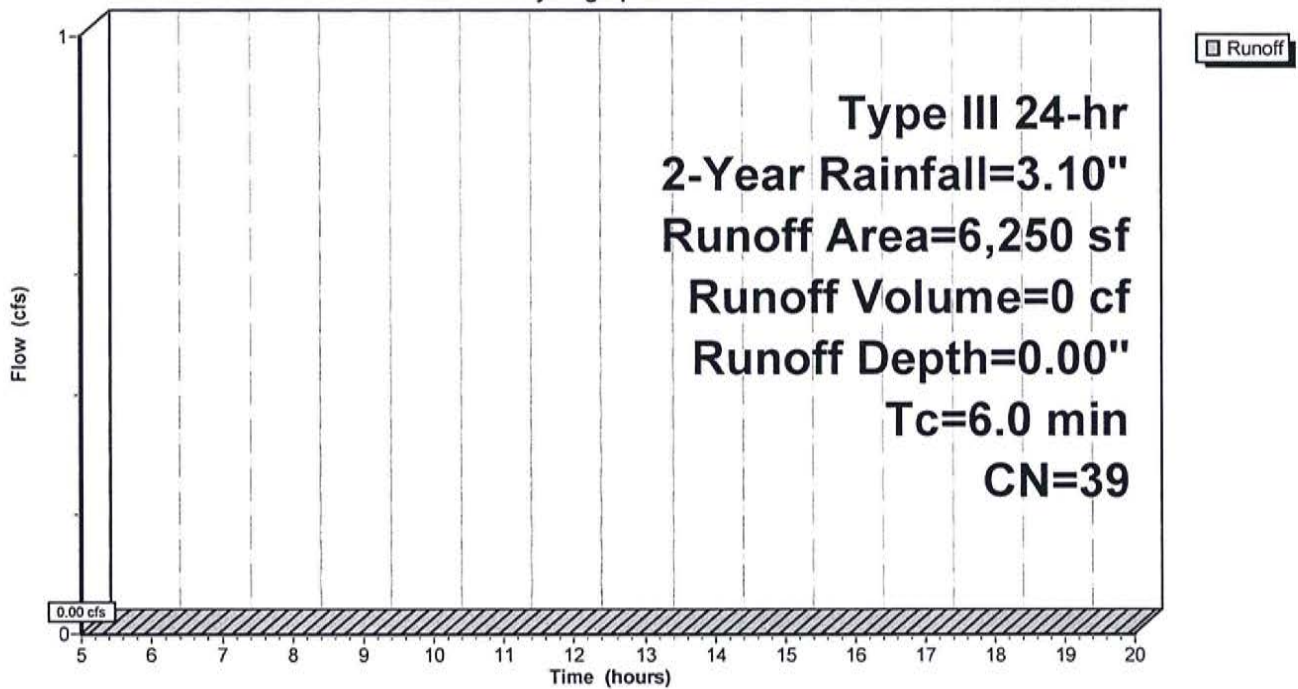

Post-Dev

Prepared by Millennium Engineering, Inc.
HydroCAD® 10.00-25 s/n 02736 © 2019 HydroCAD Software Solutions LLC

Type III 24-hr 2-Year Rainfall=3.10"

Printed 8/27/2020

Page 10

Summary for Subcatchment 100S: Area 100S

Runoff = 0.00 cfs @ 5.00 hrs, Volume= 0 cf, Depth= 0.00"

Runoff by SCS TR-20 method, UH=SCS, Weighted-CN, Time Span= 5.00-20.00 hrs, dt= 0.05 hrs
Type III 24-hr 2-Year Rainfall=3.10"

Area (sf)	CN	Description
7,145	39	>75% Grass cover, Good, HSG A
600	30	Woods, Good, HSG A
7,745	38	Weighted Average
7,745		100.00% Pervious Area

Tc (min)	Length (feet)	Slope (ft/ft)	Velocity (ft/sec)	Capacity (cfs)	Description
6.0					Direct Entry,

Subcatchment 100S: Area 100S

Hydrograph

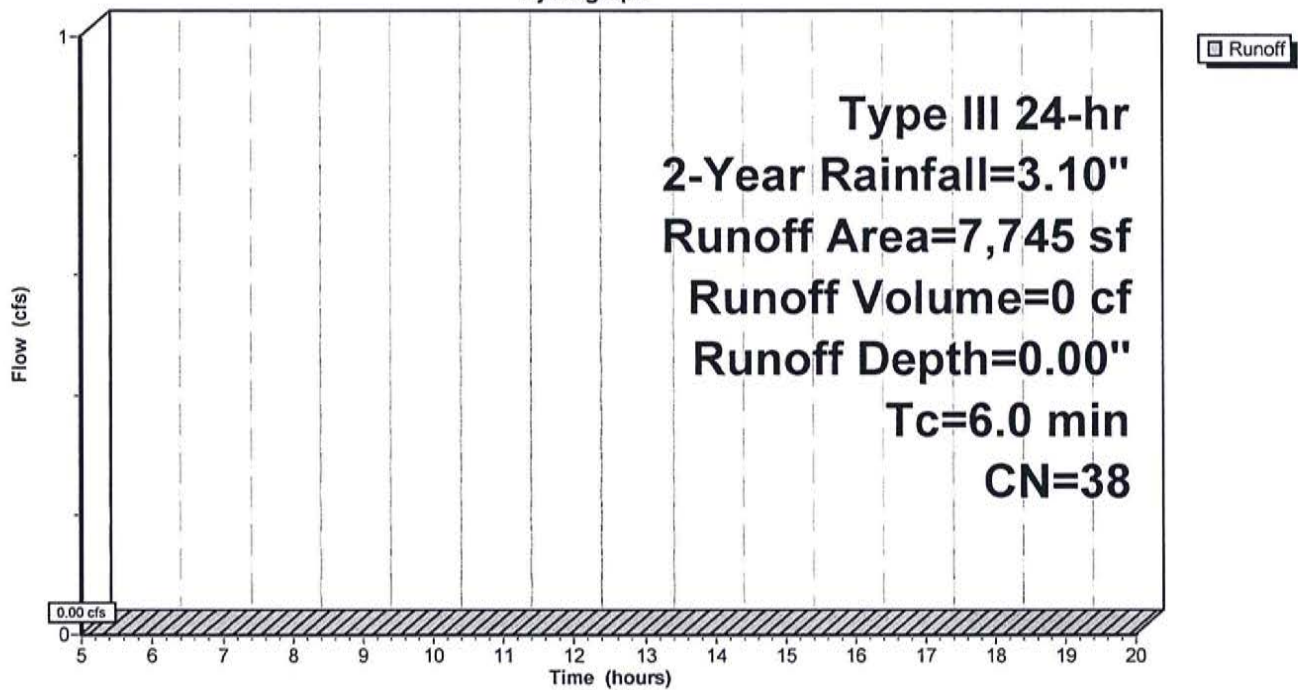

Post-Dev

Prepared by Millennium Engineering, Inc.
HydroCAD® 10.00-25 s/n 02736 © 2019 HydroCAD Software Solutions LLC

Type III 24-hr 2-Year Rainfall=3.10"

Printed 8/27/2020

Page 11

Summary for Subcatchment 200S: Area 200S

Runoff = 0.00 cfs @ 5.00 hrs, Volume= 0 cf, Depth= 0.00"

Runoff by SCS TR-20 method, UH=SCS, Weighted-CN, Time Span= 5.00-20.00 hrs, dt= 0.05 hrs
Type III 24-hr 2-Year Rainfall=3.10"

Area (sf)	CN	Description
3,335	39	>75% Grass cover, Good, HSG A
3,335		100.00% Pervious Area

Tc (min)	Length (feet)	Slope (ft/ft)	Velocity (ft/sec)	Capacity (cfs)	Description
6.0					Direct Entry,

Subcatchment 200S: Area 200S

Hydrograph

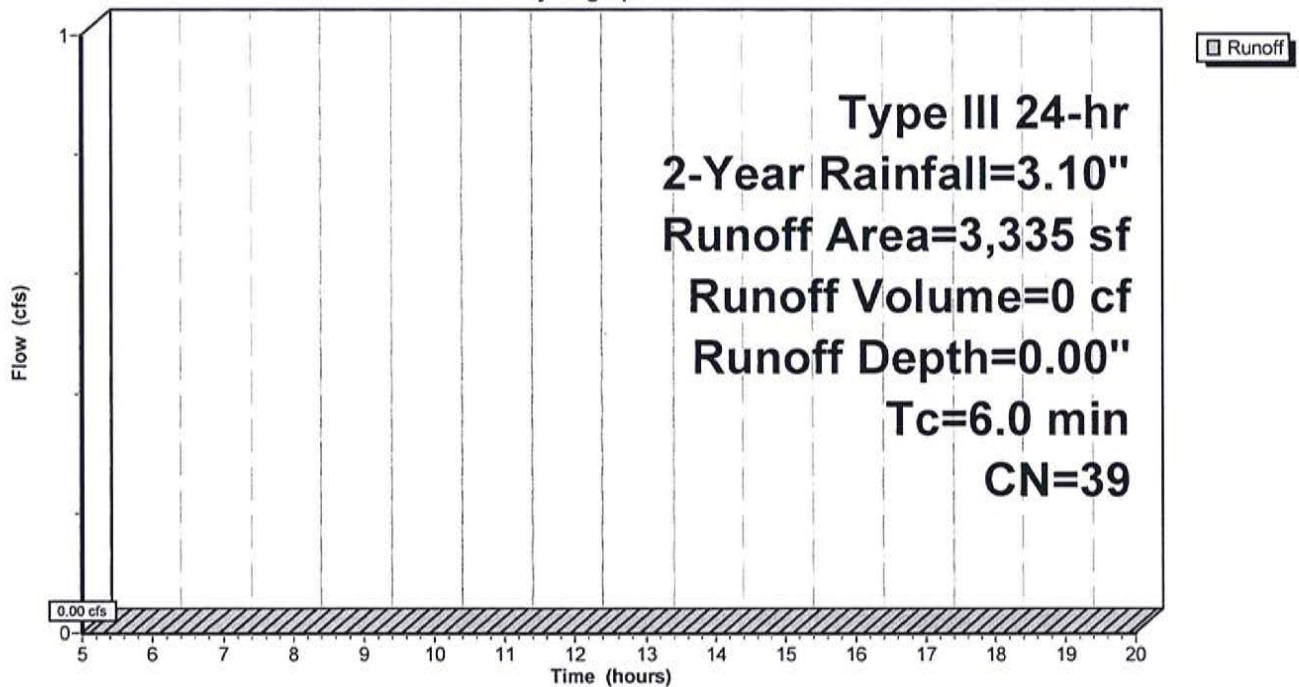

Post-Dev

Prepared by Millennium Engineering, Inc.
 HydroCAD® 10.00-25 s/n 02736 © 2019 HydroCAD Software Solutions LLC

Type III 24-hr 2-Year Rainfall=3.10"

Printed 8/27/2020

Page 12

Summary for Subcatchment 300S: Area 300S

Runoff = 0.01 cfs @ 12.14 hrs, Volume= 28 cf, Depth> 0.35"

Runoff by SCS TR-20 method, UH=SCS, Weighted-CN, Time Span= 5.00-20.00 hrs, dt= 0.05 hrs
 Type III 24-hr 2-Year Rainfall=3.10"

Area (sf)	CN	Description
610	39	>75% Grass cover, Good, HSG A
350	98	Paved parking, HSG A
960	61	Weighted Average
610		63.54% Pervious Area
350		36.46% Impervious Area

Tc (min)	Length (feet)	Slope (ft/ft)	Velocity (ft/sec)	Capacity (cfs)	Description
6.0					Direct Entry,

Subcatchment 300S: Area 300S

Hydrograph

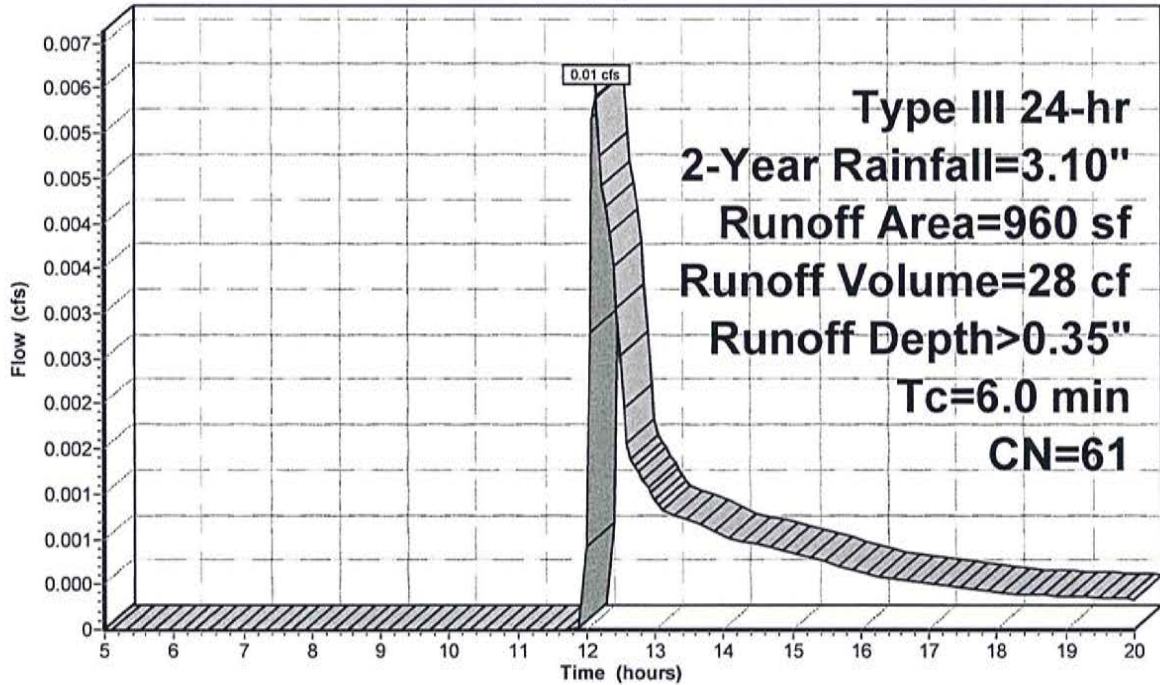

Runoff

Post-Dev

Prepared by Millennium Engineering, Inc.
HydroCAD® 10.00-25 s/n 02736 © 2019 HydroCAD Software Solutions LLC

Type III 24-hr 2-Year Rainfall=3.10"

Printed 8/27/2020

Page 13

Summary for Pond 1P: Infiltration Basin

Inflow Area = 27,600 sf, 73.46% Impervious, Inflow Depth > 1.85" for 2-Year event
 Inflow = 1.23 cfs @ 12.05 hrs, Volume= 4,263 cf
 Outflow = 0.21 cfs @ 12.56 hrs, Volume= 4,258 cf, Atten= 83%, Lag= 30.1 min
 Discarded = 0.21 cfs @ 12.56 hrs, Volume= 4,258 cf
 Primary = 0.00 cfs @ 5.00 hrs, Volume= 0 cf

Routing by Stor-Ind method, Time Span= 5.00-20.00 hrs, dt= 0.05 hrs
 Peak Elev= 18.53' @ 12.56 hrs Surf.Area= 3,049 sf Storage= 1,442 cf
 Flood Elev= 19.50' Surf.Area= 4,230 sf Storage= 4,976 cf

Plug-Flow detention time= 54.1 min calculated for 4,244 cf (100% of inflow)
 Center-of-Mass det. time= 53.3 min (805.8 - 752.5)

Volume	Invert	Avail.Storage	Storage Description
#1	18.00'	4,976 cf	Custom Stage Data (Prismatic) Listed below (Recalc)

Elevation (feet)	Surf.Area (sq-ft)	Inc.Store (cubic-feet)	Cum.Store (cubic-feet)
18.00	2,430	0	0
19.00	3,605	3,018	3,018
19.50	4,230	1,959	4,976

Device	Routing	Invert	Outlet Devices
#1	Discarded	18.00'	2.410 in/hr Exfiltration over Surface area Conductivity to Groundwater Elevation = 16.00'
#2	Primary	19.00'	15.0' long x 9.0' breadth Broad-Crested Rectangular Weir Head (feet) 0.20 0.40 0.60 0.80 1.00 1.20 1.40 1.60 1.80 2.00 2.50 3.00 3.50 4.00 4.50 5.00 5.50 Coef. (English) 2.46 2.55 2.70 2.69 2.68 2.68 2.67 2.64 2.64 2.64 2.65 2.64 2.65 2.65 2.66 2.67 2.69

Discarded OutFlow Max=0.21 cfs @ 12.56 hrs HW=18.53' (Free Discharge)
 ↑1=Exfiltration (Controls 0.21 cfs)

Primary OutFlow Max=0.00 cfs @ 5.00 hrs HW=18.00' (Free Discharge)
 ↑2=Broad-Crested Rectangular Weir (Controls 0.00 cfs)

Pond 1P: Infiltration Basin

Hydrograph

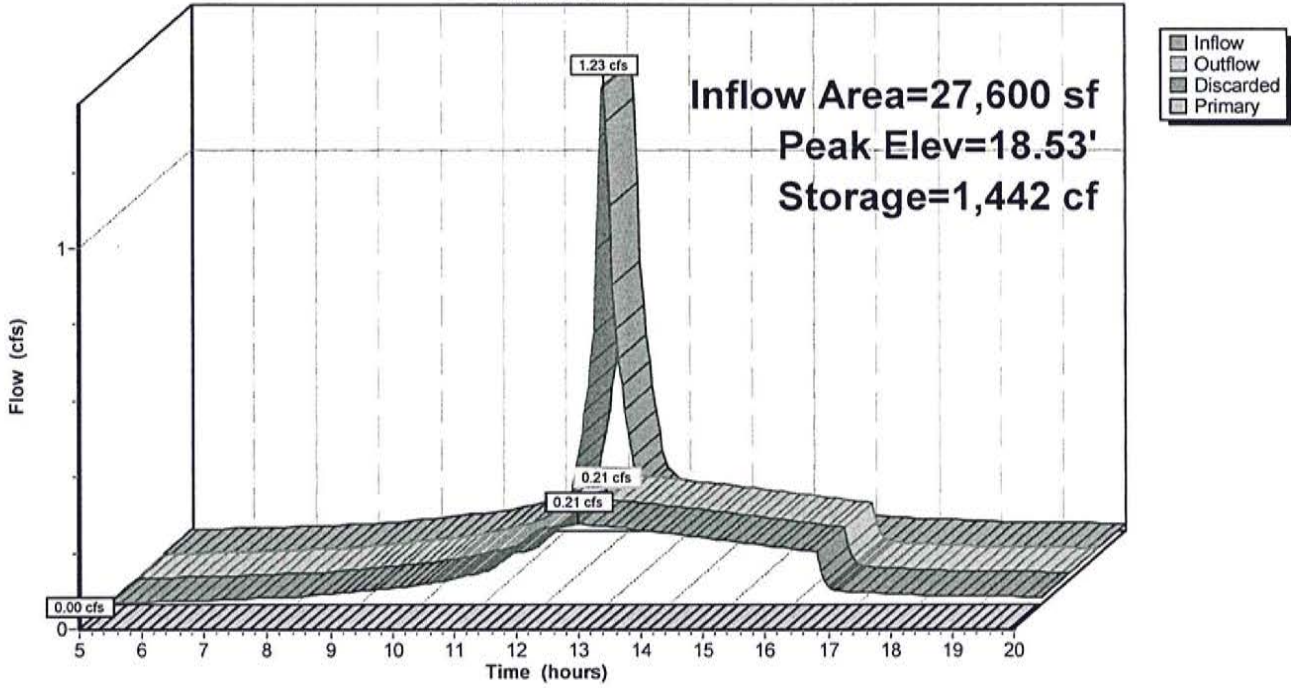

Summary for Link 100L: Pond

Inflow Area = 35,345 sf, 57.36% Impervious, Inflow Depth = 0.00" for 2-Year event
Inflow = 0.00 cfs @ 5.00 hrs, Volume= 0 cf
Primary = 0.00 cfs @ 5.00 hrs, Volume= 0 cf, Atten= 0%, Lag= 0.0 min

Primary outflow = Inflow, Time Span= 5.00-20.00 hrs, dt= 0.05 hrs

Link 100L: Pond

Hydrograph

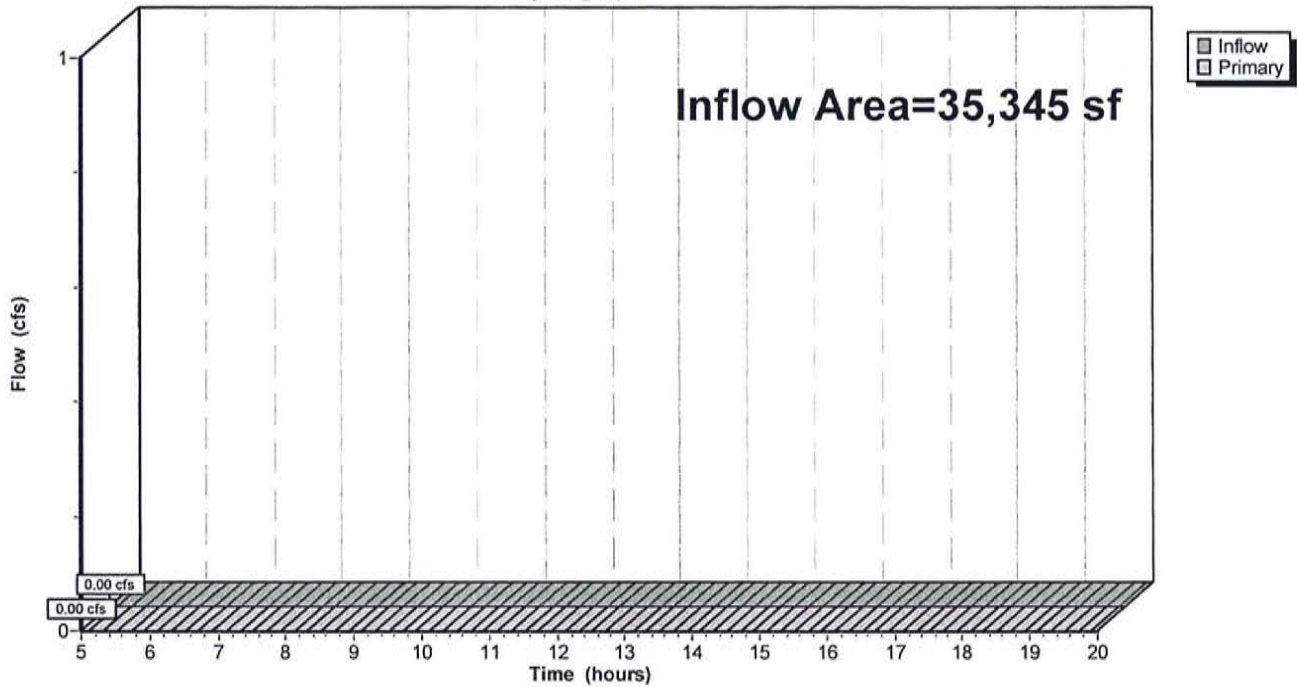

Summary for Link 200L: Wetlands

Inflow Area = 3,335 sf, 0.00% Impervious, Inflow Depth = 0.00" for 2-Year event
Inflow = 0.00 cfs @ 5.00 hrs, Volume= 0 cf
Primary = 0.00 cfs @ 5.00 hrs, Volume= 0 cf, Atten= 0%, Lag= 0.0 min

Primary outflow = Inflow, Time Span= 5.00-20.00 hrs, dt= 0.05 hrs

Link 200L: Wetlands

Hydrograph

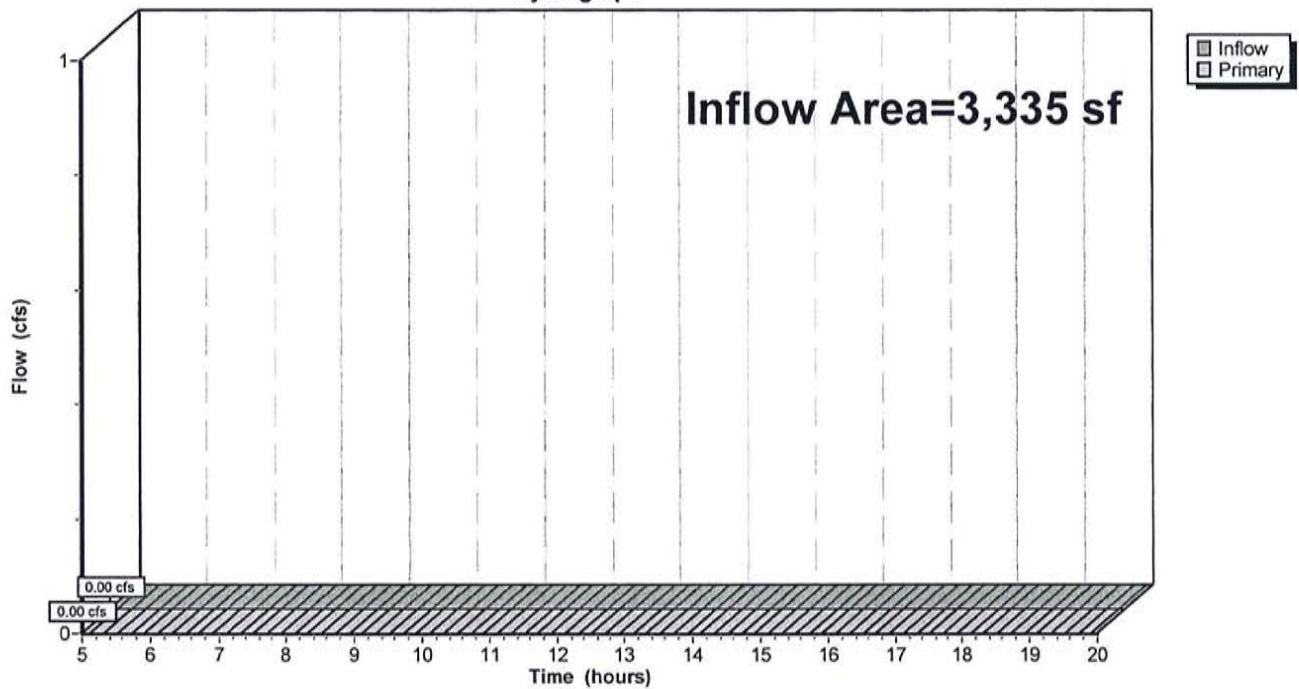

Summary for Link 300L: Route 1

Inflow Area = 960 sf, 36.46% Impervious, Inflow Depth > 0.35" for 2-Year event
Inflow = 0.01 cfs @ 12.14 hrs, Volume= 28 cf
Primary = 0.01 cfs @ 12.14 hrs, Volume= 28 cf, Atten= 0%, Lag= 0.0 min

Primary outflow = Inflow, Time Span= 5.00-20.00 hrs, dt= 0.05 hrs

Link 300L: Route 1

Hydrograph

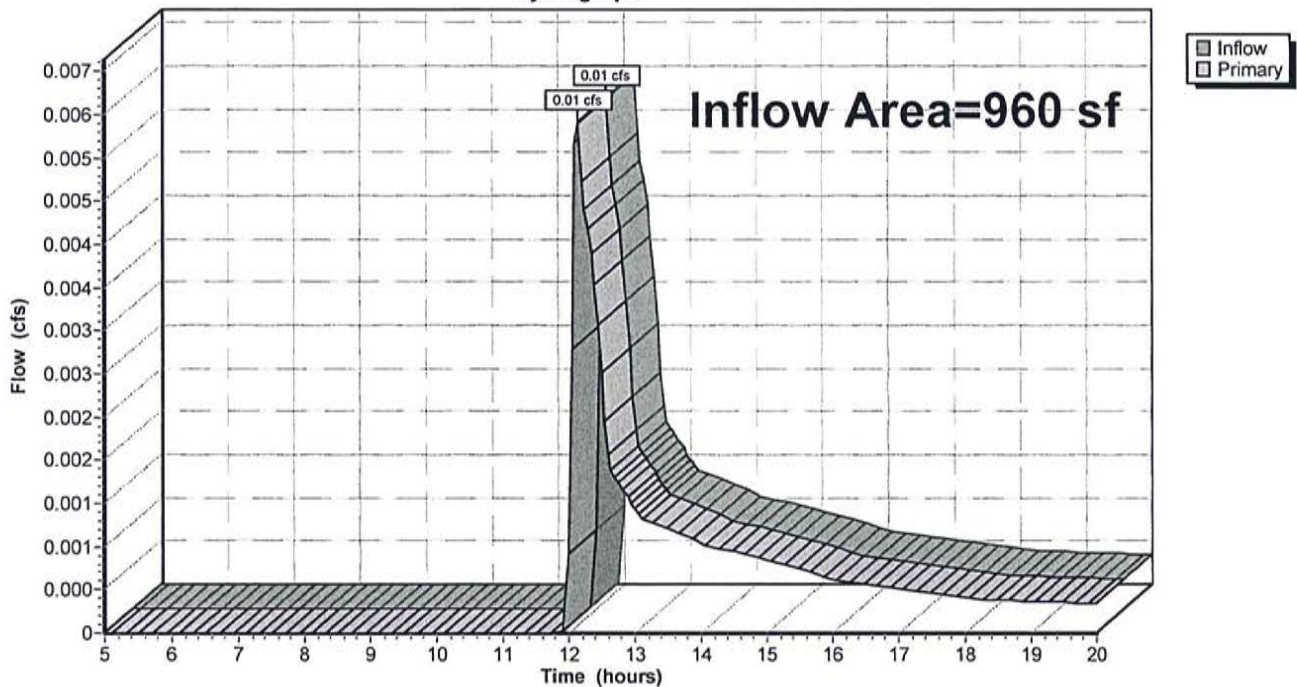

Post-Dev

Type III 24-hr 10-Year Rainfall=4.50"

Prepared by Millennium Engineering, Inc.

Printed 8/27/2020

HydroCAD® 10.00-25 s/n 02736 © 2019 HydroCAD Software Solutions LLC

Page 18

Time span=5.00-20.00 hrs, dt=0.05 hrs, 301 points
Runoff by SCS TR-20 method, UH=SCS, Weighted-CN
Reach routing by Stor-Ind+Trans method - Pond routing by Stor-Ind method

Subcatchment 1S: Area 1S	Runoff Area=11,350 sf 93.83% Impervious Runoff Depth>3.60" Tc=6.0 min CN=94 Runoff=1.07 cfs 3,407 cf
Subcatchment 2S: Area 2S	Runoff Area=7,000 sf 94.64% Impervious Runoff Depth>3.70" Tc=0.0 min CN=95 Runoff=0.78 cfs 2,160 cf
Subcatchment 3S: Area 3S	Runoff Area=3,000 sf 100.00% Impervious Runoff Depth>3.96" Tc=6.0 min CN=98 Runoff=0.30 cfs 991 cf
Subcatchment 4S: Area 4S	Runoff Area=6,250 sf 0.00% Impervious Runoff Depth>0.08" Tc=6.0 min CN=39 Runoff=0.00 cfs 43 cf
Subcatchment 100S: Area 100S	Runoff Area=7,745 sf 0.00% Impervious Runoff Depth>0.06" Tc=6.0 min CN=38 Runoff=0.00 cfs 40 cf
Subcatchment 200S: Area 200S	Runoff Area=3,335 sf 0.00% Impervious Runoff Depth>0.08" Tc=6.0 min CN=39 Runoff=0.00 cfs 23 cf
Subcatchment 300S: Area 300S	Runoff Area=960 sf 36.46% Impervious Runoff Depth>0.97" Tc=6.0 min CN=61 Runoff=0.02 cfs 78 cf
Pond 1P: Infiltration Basin	Peak Elev=18.85' Storage=2,474 cf Inflow=1.85 cfs 6,600 cf Discarded=0.26 cfs 6,592 cf Primary=0.00 cfs 0 cf Outflow=0.26 cfs 6,592 cf
Link 100L: Pond	Inflow=0.00 cfs 40 cf Primary=0.00 cfs 40 cf
Link 200L: Wetlands	Inflow=0.00 cfs 23 cf Primary=0.00 cfs 23 cf
Link 300L: Route 1	Inflow=0.02 cfs 78 cf Primary=0.02 cfs 78 cf

Total Runoff Area = 39,640 sf Runoff Volume = 6,741 cf Average Runoff Depth = 2.04"
47.97% Pervious = 19,015 sf 52.03% Impervious = 20,625 sf

Post-Dev

Type III 24-hr 10-Year Rainfall=4.50"

Prepared by Millennium Engineering, Inc.

Printed 8/27/2020

HydroCAD® 10.00-25 s/n 02736 © 2019 HydroCAD Software Solutions LLC

Page 19

Summary for Subcatchment 1S: Area 1S

Runoff = 1.07 cfs @ 12.09 hrs, Volume= 3,407 cf, Depth> 3.60"

Runoff by SCS TR-20 method, UH=SCS, Weighted-CN, Time Span= 5.00-20.00 hrs, dt= 0.05 hrs
Type III 24-hr 10-Year Rainfall=4.50"

Area (sf)	CN	Description
10,650	98	Paved parking, HSG A
700	39	>75% Grass cover, Good, HSG A
11,350	94	Weighted Average
700		6.17% Pervious Area
10,650		93.83% Impervious Area

Tc (min)	Length (feet)	Slope (ft/ft)	Velocity (ft/sec)	Capacity (cfs)	Description
6.0					Direct Entry,

Subcatchment 1S: Area 1S

Hydrograph

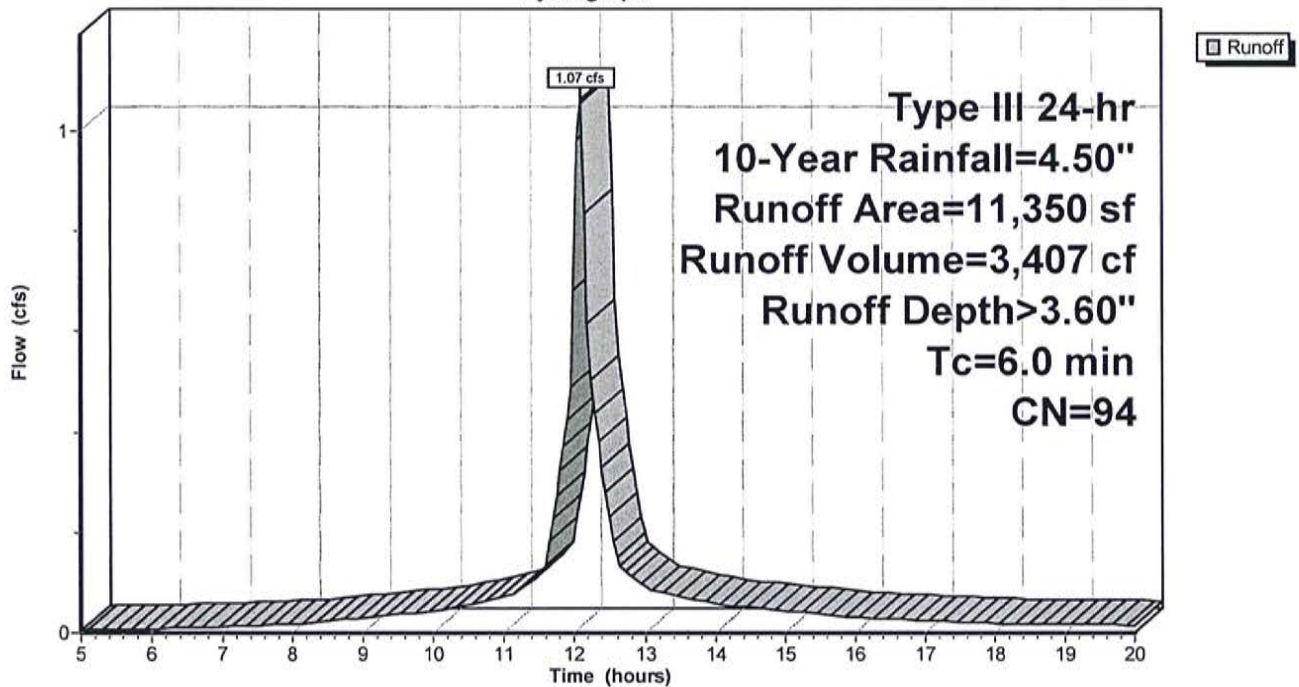

Summary for Subcatchment 2S: Area 2S

Runoff = 0.78 cfs @ 12.00 hrs, Volume= 2,160 cf, Depth> 3.70"

Runoff by SCS TR-20 method, UH=SCS, Weighted-CN, Time Span= 5.00-20.00 hrs, dt= 0.05 hrs
 Type III 24-hr 10-Year Rainfall=4.50"

Area (sf)	CN	Description
6,625	98	Paved parking, HSG A
375	39	>75% Grass cover, Good, HSG A
7,000	95	Weighted Average
375		5.36% Pervious Area
6,625		94.64% Impervious Area

Subcatchment 2S: Area 2S

Hydrograph

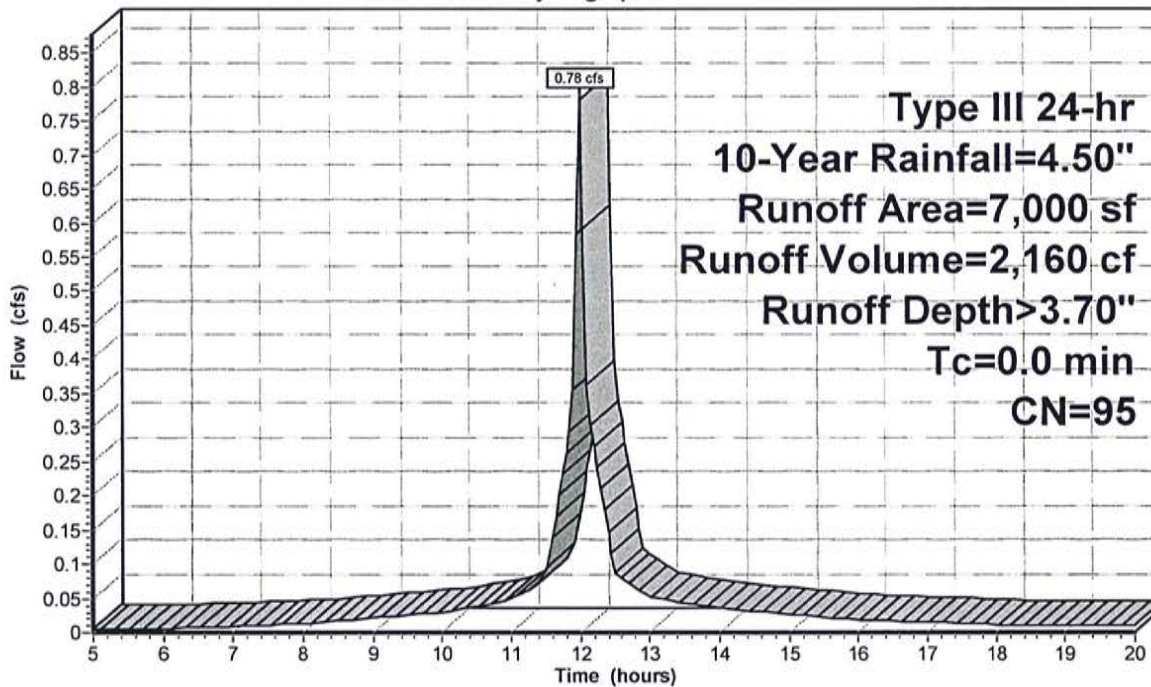

Runoff

Type III 24-hr
 10-Year Rainfall=4.50"
 Runoff Area=7,000 sf
 Runoff Volume=2,160 cf
 Runoff Depth>3.70"
 Tc=0.0 min
 CN=95

Post-Dev

Prepared by Millennium Engineering, Inc.
HydroCAD® 10.00-25 s/n 02736 © 2019 HydroCAD Software Solutions LLC

Type III 24-hr 10-Year Rainfall=4.50"

Printed 8/27/2020

Page 21

Summary for Subcatchment 3S: Area 3S

Runoff = 0.30 cfs @ 12.09 hrs, Volume= 991 cf, Depth> 3.96"

Runoff by SCS TR-20 method, UH=SCS, Weighted-CN, Time Span= 5.00-20.00 hrs, dt= 0.05 hrs
Type III 24-hr 10-Year Rainfall=4.50"

Area (sf)	CN	Description
3,000	98	Roofs, HSG A
3,000		100.00% Impervious Area

Tc (min)	Length (feet)	Slope (ft/ft)	Velocity (ft/sec)	Capacity (cfs)	Description
6.0					Direct Entry,

Subcatchment 3S: Area 3S

Hydrograph

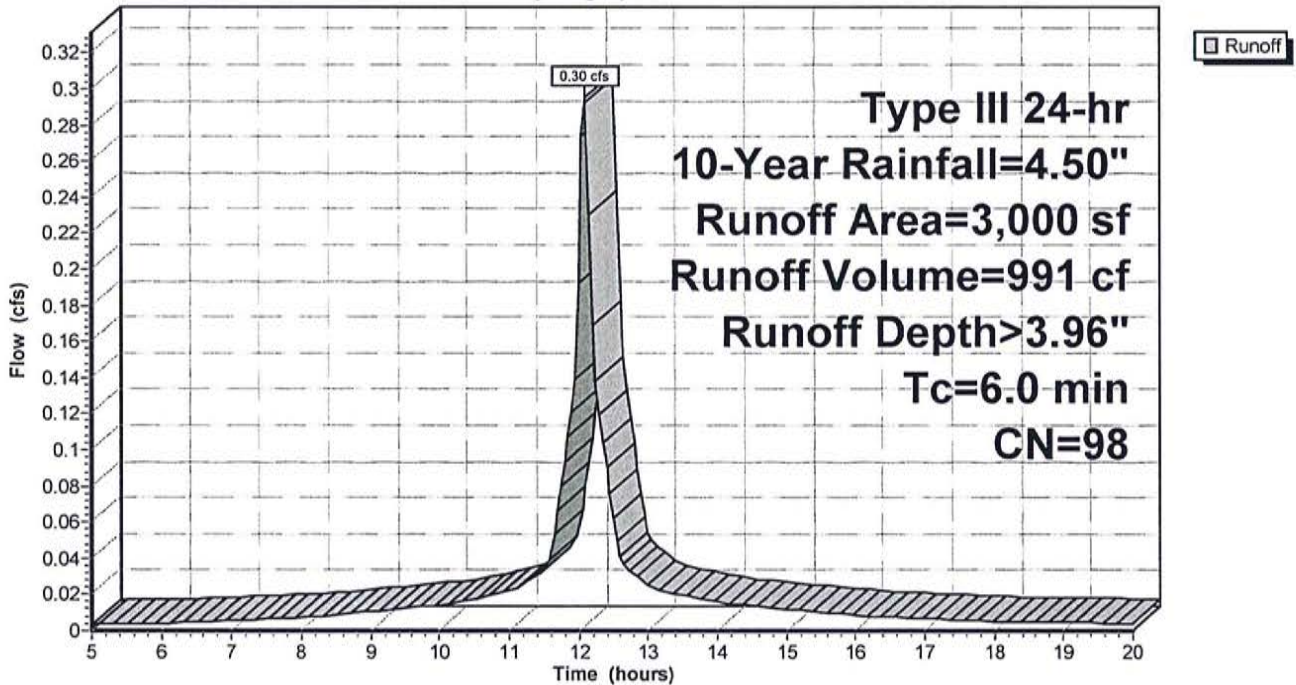

Post-Dev

Type III 24-hr 10-Year Rainfall=4.50"

Prepared by Millennium Engineering, Inc.

Printed 8/27/2020

HydroCAD® 10.00-25 s/n 02736 © 2019 HydroCAD Software Solutions LLC

Page 22

Summary for Subcatchment 4S: Area 4S

Runoff = 0.00 cfs @ 14.71 hrs, Volume= 43 cf, Depth> 0.08"

Runoff by SCS TR-20 method, UH=SCS, Weighted-CN, Time Span= 5.00-20.00 hrs, dt= 0.05 hrs
 Type III 24-hr 10-Year Rainfall=4.50"

Area (sf)	CN	Description
6,250	39	>75% Grass cover, Good, HSG A
6,250		100.00% Pervious Area

Tc (min)	Length (feet)	Slope (ft/ft)	Velocity (ft/sec)	Capacity (cfs)	Description
6.0					Direct Entry,

Subcatchment 4S: Area 4S

Hydrograph

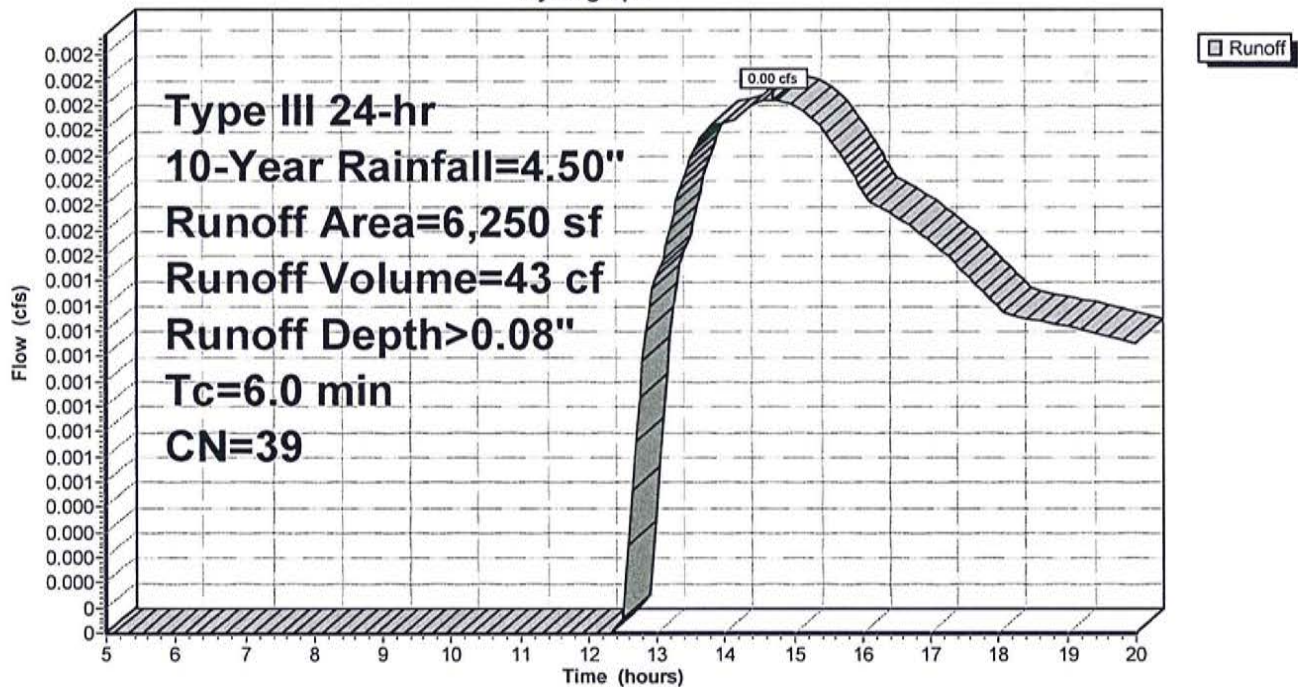

Post-Dev

Prepared by Millennium Engineering, Inc.
 HydroCAD® 10.00-25 s/n 02736 © 2019 HydroCAD Software Solutions LLC

Type III 24-hr 10-Year Rainfall=4.50"

Printed 8/27/2020

Page 23

Summary for Subcatchment 100S: Area 100S

Runoff = 0.00 cfs @ 14.98 hrs, Volume= 40 cf, Depth> 0.06"

Runoff by SCS TR-20 method, UH=SCS, Weighted-CN, Time Span= 5.00-20.00 hrs, dt= 0.05 hrs
 Type III 24-hr 10-Year Rainfall=4.50"

Area (sf)	CN	Description
7,145	39	>75% Grass cover, Good, HSG A
600	30	Woods, Good, HSG A
7,745	38	Weighted Average
7,745		100.00% Pervious Area

Tc (min)	Length (feet)	Slope (ft/ft)	Velocity (ft/sec)	Capacity (cfs)	Description
6.0					Direct Entry,

Subcatchment 100S: Area 100S

Hydrograph

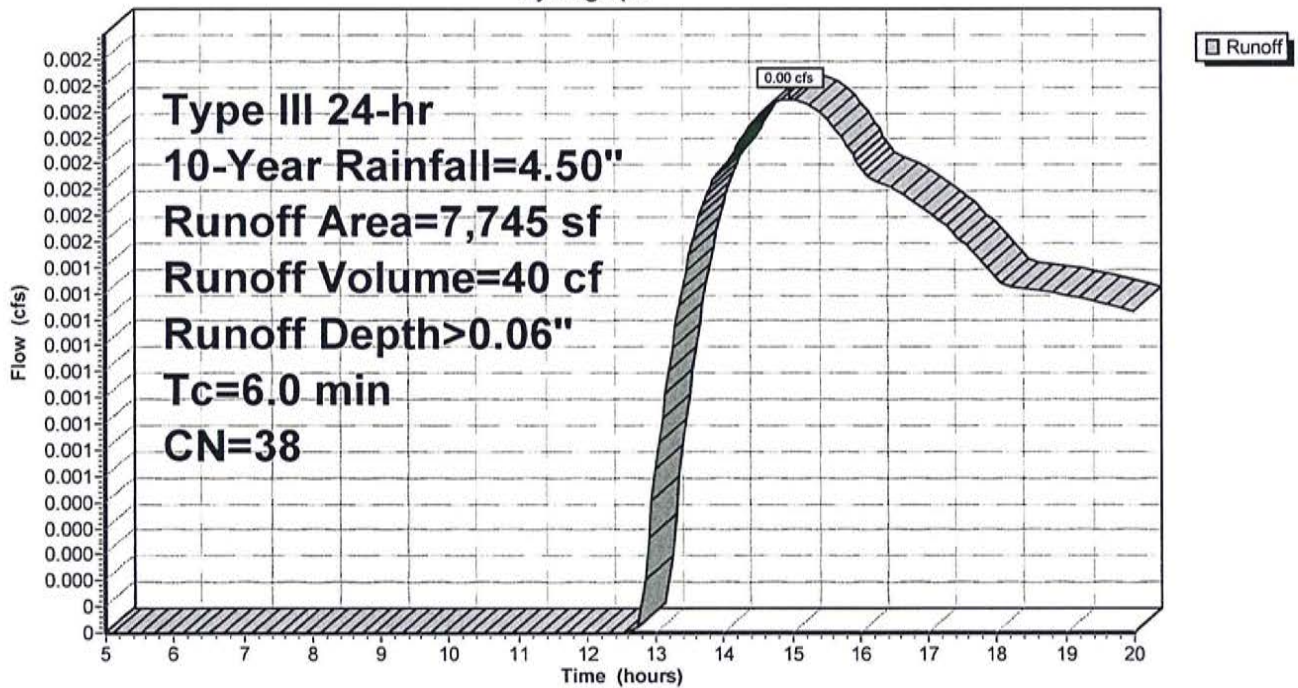

Post-Dev

Type III 24-hr 10-Year Rainfall=4.50"

Prepared by Millennium Engineering, Inc.

Printed 8/27/2020

HydroCAD® 10.00-25 s/n 02736 © 2019 HydroCAD Software Solutions LLC

Page 24

Summary for Subcatchment 200S: Area 200S

Runoff = 0.00 cfs @ 14.71 hrs, Volume= 23 cf, Depth> 0.08"

Runoff by SCS TR-20 method, UH=SCS, Weighted-CN, Time Span= 5.00-20.00 hrs, dt= 0.05 hrs
Type III 24-hr 10-Year Rainfall=4.50"

Area (sf)	CN	Description
3,335	39	>75% Grass cover, Good, HSG A
3,335		100.00% Pervious Area

Tc (min)	Length (feet)	Slope (ft/ft)	Velocity (ft/sec)	Capacity (cfs)	Description
6.0					Direct Entry,

Subcatchment 200S: Area 200S

Hydrograph

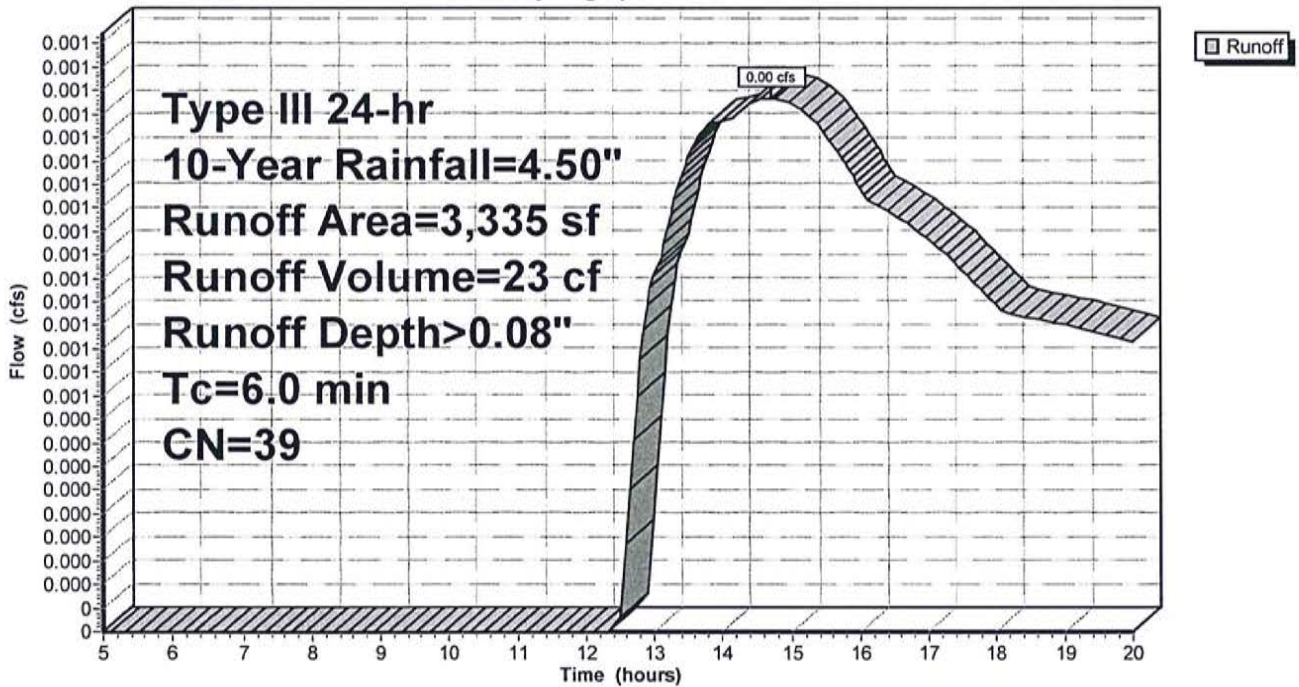

Post-Dev

Prepared by Millennium Engineering, Inc.
 HydroCAD® 10.00-25 s/n 02736 © 2019 HydroCAD Software Solutions LLC

Type III 24-hr 10-Year Rainfall=4.50"

Printed 8/27/2020

Page 25

Summary for Subcatchment 300S: Area 300S

Runoff = 0.02 cfs @ 12.11 hrs, Volume= 78 cf, Depth> 0.97"

Runoff by SCS TR-20 method, UH=SCS, Weighted-CN, Time Span= 5.00-20.00 hrs, dt= 0.05 hrs
 Type III 24-hr 10-Year Rainfall=4.50"

Area (sf)	CN	Description
610	39	>75% Grass cover, Good, HSG A
350	98	Paved parking, HSG A
960	61	Weighted Average
610		63.54% Pervious Area
350		36.46% Impervious Area

Tc (min)	Length (feet)	Slope (ft/ft)	Velocity (ft/sec)	Capacity (cfs)	Description
6.0					Direct Entry,

Subcatchment 300S: Area 300S

Hydrograph

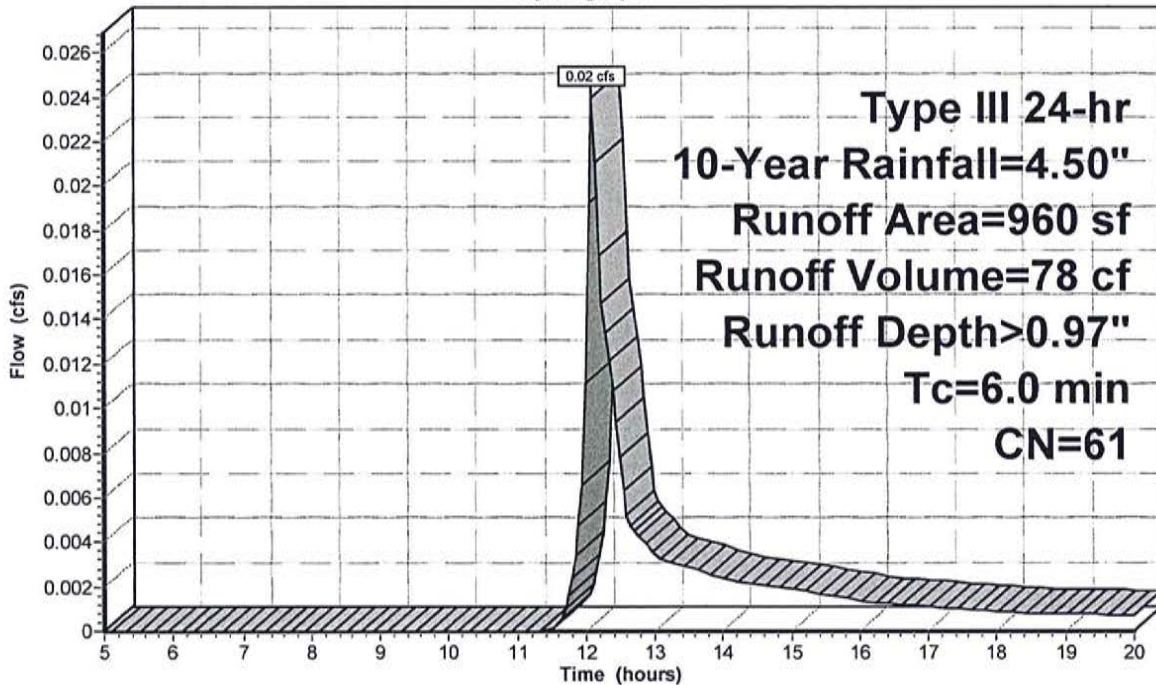

Post-Dev

Type III 24-hr 10-Year Rainfall=4.50"

Prepared by Millennium Engineering, Inc.

Printed 8/27/2020

HydroCAD® 10.00-25 s/n 02736 © 2019 HydroCAD Software Solutions LLC

Page 26

Summary for Pond 1P: Infiltration Basin

Inflow Area = 27,600 sf, 73.46% Impervious, Inflow Depth > 2.87" for 10-Year event
 Inflow = 1.85 cfs @ 12.05 hrs, Volume= 6,600 cf
 Outflow = 0.26 cfs @ 12.62 hrs, Volume= 6,592 cf, Atten= 86%, Lag= 34.2 min
 Discarded = 0.26 cfs @ 12.62 hrs, Volume= 6,592 cf
 Primary = 0.00 cfs @ 5.00 hrs, Volume= 0 cf

Routing by Stor-Ind method, Time Span= 5.00-20.00 hrs, dt= 0.05 hrs
 Peak Elev= 18.85' @ 12.62 hrs Surf.Area= 3,423 sf Storage= 2,474 cf
 Flood Elev= 19.50' Surf.Area= 4,230 sf Storage= 4,976 cf

Plug-Flow detention time= 84.0 min calculated for 6,591 cf (100% of inflow)
 Center-of-Mass det. time= 83.3 min (830.1 - 746.8)

Volume	Invert	Avail.Storage	Storage Description
#1	18.00'	4,976 cf	Custom Stage Data (Prismatic) Listed below (Recalc)

Elevation (feet)	Surf.Area (sq-ft)	Inc.Store (cubic-feet)	Cum.Store (cubic-feet)
18.00	2,430	0	0
19.00	3,605	3,018	3,018
19.50	4,230	1,959	4,976

Device	Routing	Invert	Outlet Devices
#1	Discarded	18.00'	2.410 in/hr Exfiltration over Surface area Conductivity to Groundwater Elevation = 16.00'
#2	Primary	19.00'	15.0' long x 9.0' breadth Broad-Crested Rectangular Weir Head (feet) 0.20 0.40 0.60 0.80 1.00 1.20 1.40 1.60 1.80 2.00 2.50 3.00 3.50 4.00 4.50 5.00 5.50 Coef. (English) 2.46 2.55 2.70 2.69 2.68 2.68 2.67 2.64 2.64 2.64 2.65 2.64 2.65 2.65 2.66 2.67 2.69

Discarded OutFlow Max=0.26 cfs @ 12.62 hrs HW=18.85' (Free Discharge)
 ↑1=Exfiltration (Controls 0.26 cfs)

Primary OutFlow Max=0.00 cfs @ 5.00 hrs HW=18.00' (Free Discharge)
 ↑2=Broad-Crested Rectangular Weir (Controls 0.00 cfs)

Pond 1P: Infiltration Basin

Hydrograph

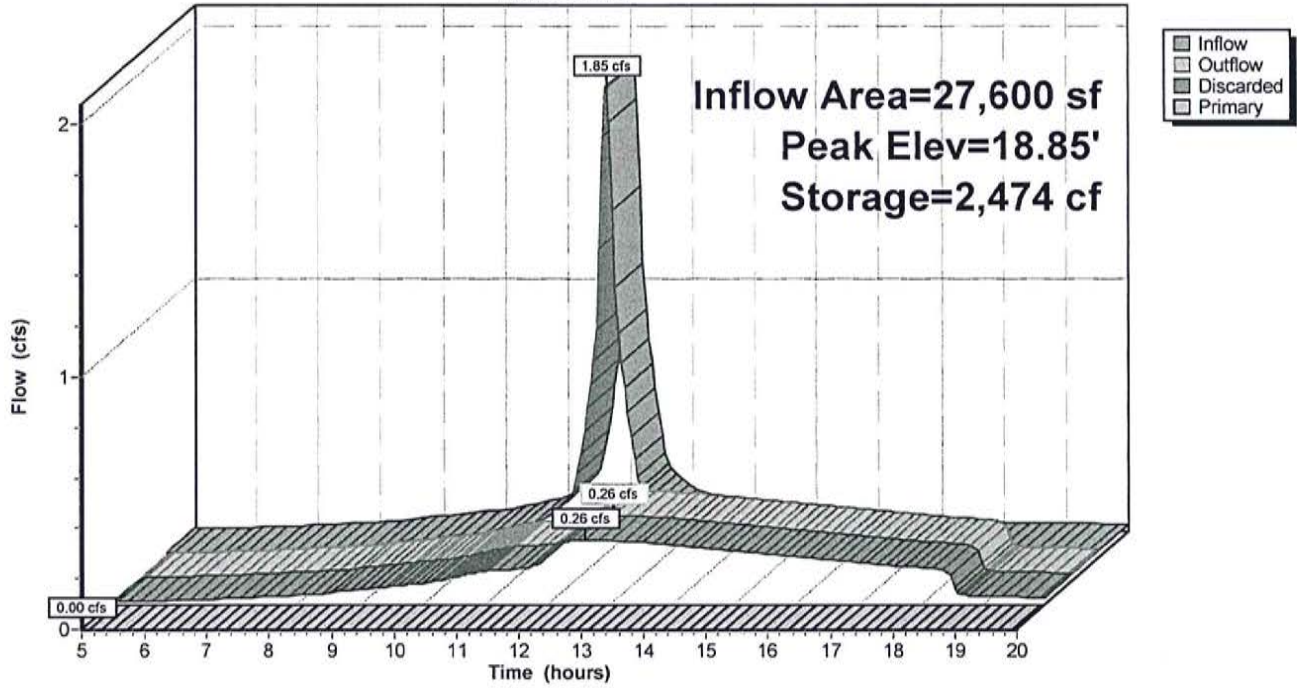

Summary for Link 100L: Pond

Inflow Area = 35,345 sf, 57.36% Impervious, Inflow Depth > 0.01" for 10-Year event
Inflow = 0.00 cfs @ 14.98 hrs, Volume= 40 cf
Primary = 0.00 cfs @ 14.98 hrs, Volume= 40 cf, Atten= 0%, Lag= 0.0 min

Primary outflow = Inflow, Time Span= 5.00-20.00 hrs, dt= 0.05 hrs

Link 100L: Pond

Hydrograph

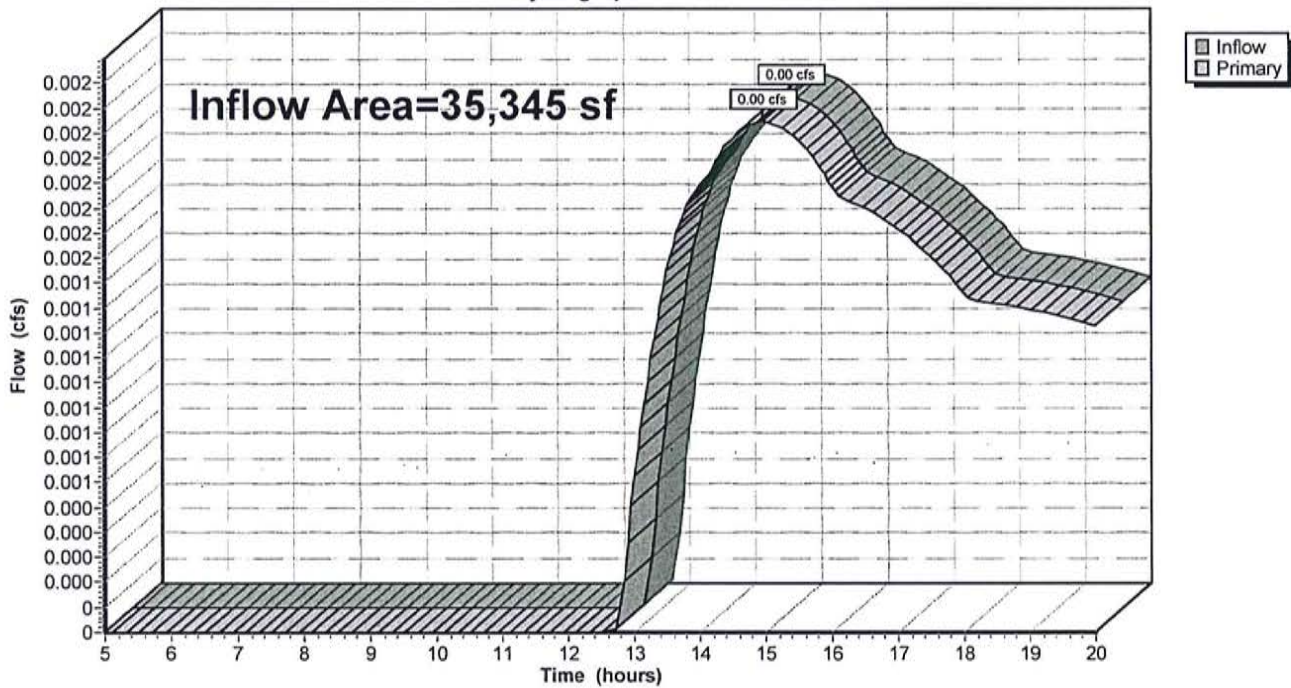

Summary for Link 200L: Wetlands

Inflow Area = 3,335 sf, 0.00% Impervious, Inflow Depth > 0.08" for 10-Year event
Inflow = 0.00 cfs @ 14.71 hrs, Volume= 23 cf
Primary = 0.00 cfs @ 14.71 hrs, Volume= 23 cf, Atten= 0%, Lag= 0.0 min

Primary outflow = Inflow, Time Span= 5.00-20.00 hrs, dt= 0.05 hrs

Link 200L: Wetlands

Hydrograph

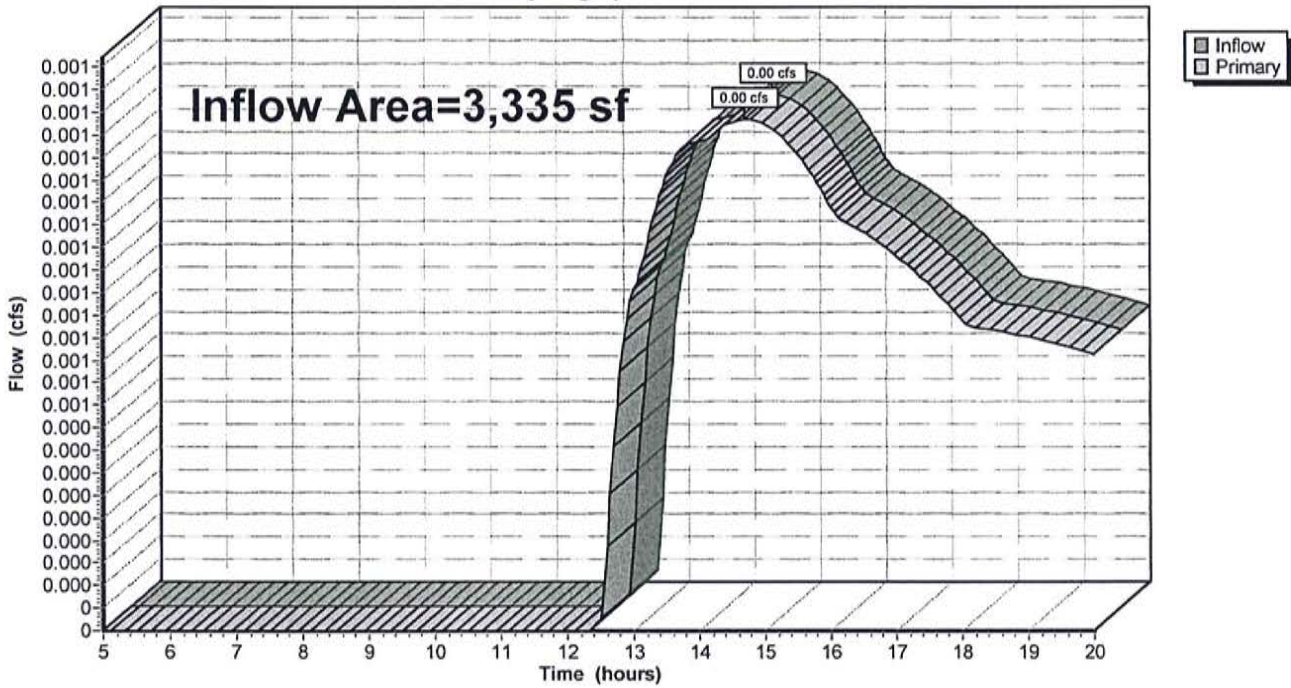

Summary for Link 300L: Route 1

Inflow Area = 960 sf, 36.46% Impervious, Inflow Depth > 0.97" for 10-Year event
Inflow = 0.02 cfs @ 12.11 hrs, Volume= 78 cf
Primary = 0.02 cfs @ 12.11 hrs, Volume= 78 cf, Atten= 0%, Lag= 0.0 min

Primary outflow = Inflow, Time Span= 5.00-20.00 hrs, dt= 0.05 hrs

Link 300L: Route 1

Hydrograph

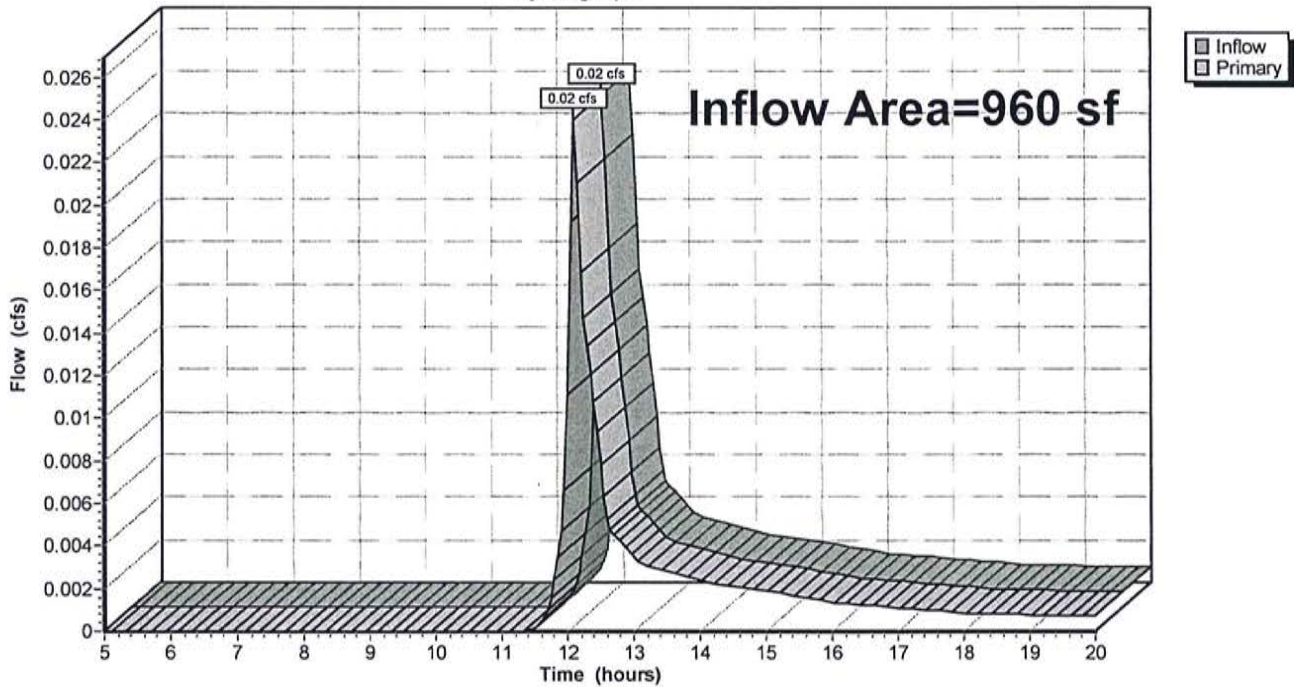

Post-Dev

Type III 24-hr 100-Year Rainfall=6.50"

Prepared by Millennium Engineering, Inc.

Printed 8/27/2020

HydroCAD® 10.00-25 s/n 02736 © 2019 HydroCAD Software Solutions LLC

Page 31

Time span=5.00-20.00 hrs, dt=0.05 hrs, 301 points
Runoff by SCS TR-20 method, UH=SCS, Weighted-CN
Reach routing by Stor-Ind+Trans method - Pond routing by Stor-Ind method

Subcatchment 1S: Area 1S	Runoff Area=11,350 sf 93.83% Impervious Runoff Depth>5.45" Tc=6.0 min CN=94 Runoff=1.58 cfs 5,153 cf
Subcatchment 2S: Area 2S	Runoff Area=7,000 sf 94.64% Impervious Runoff Depth>5.55" Tc=0.0 min CN=95 Runoff=1.15 cfs 3,235 cf
Subcatchment 3S: Area 3S	Runoff Area=3,000 sf 100.00% Impervious Runoff Depth>5.78" Tc=6.0 min CN=98 Runoff=0.43 cfs 1,446 cf
Subcatchment 4S: Area 4S	Runoff Area=6,250 sf 0.00% Impervious Runoff Depth>0.51" Tc=6.0 min CN=39 Runoff=0.04 cfs 265 cf
Subcatchment 100S: Area 100S	Runoff Area=7,745 sf 0.00% Impervious Runoff Depth>0.45" Tc=6.0 min CN=38 Runoff=0.04 cfs 292 cf
Subcatchment 200S: Area 200S	Runoff Area=3,335 sf 0.00% Impervious Runoff Depth>0.51" Tc=6.0 min CN=39 Runoff=0.02 cfs 141 cf
Subcatchment 300S: Area 300S	Runoff Area=960 sf 36.46% Impervious Runoff Depth>2.15" Tc=6.0 min CN=61 Runoff=0.06 cfs 172 cf
Pond 1P: Infiltration Basin	Peak Elev=19.09' Storage=3,334 cf Inflow=2.74 cfs 10,099 cf Discarded=0.30 cfs 8,777 cf Primary=0.94 cfs 1,201 cf Outflow=1.24 cfs 9,978 cf
Link 100L: Pond	Inflow=0.98 cfs 1,493 cf Primary=0.98 cfs 1,493 cf
Link 200L: Wetlands	Inflow=0.02 cfs 141 cf Primary=0.02 cfs 141 cf
Link 300L: Route 1	Inflow=0.06 cfs 172 cf Primary=0.06 cfs 172 cf

Total Runoff Area = 39,640 sf Runoff Volume = 10,704 cf Average Runoff Depth = 3.24"
47.97% Pervious = 19,015 sf 52.03% Impervious = 20,625 sf

Post-Dev

Prepared by Millennium Engineering, Inc.
 HydroCAD® 10.00-25 s/n 02736 © 2019 HydroCAD Software Solutions LLC

Type III 24-hr 100-Year Rainfall=6.50"

Printed 8/27/2020

Page 32

Summary for Subcatchment 1S: Area 1S

Runoff = 1.58 cfs @ 12.09 hrs, Volume= 5,153 cf, Depth> 5.45"

Runoff by SCS TR-20 method, UH=SCS, Weighted-CN, Time Span= 5.00-20.00 hrs, dt= 0.05 hrs
 Type III 24-hr 100-Year Rainfall=6.50"

Area (sf)	CN	Description
10,650	98	Paved parking, HSG A
700	39	>75% Grass cover, Good, HSG A
11,350	94	Weighted Average
700		6.17% Pervious Area
10,650		93.83% Impervious Area

Tc (min)	Length (feet)	Slope (ft/ft)	Velocity (ft/sec)	Capacity (cfs)	Description
6.0					Direct Entry,

Subcatchment 1S: Area 1S

Hydrograph

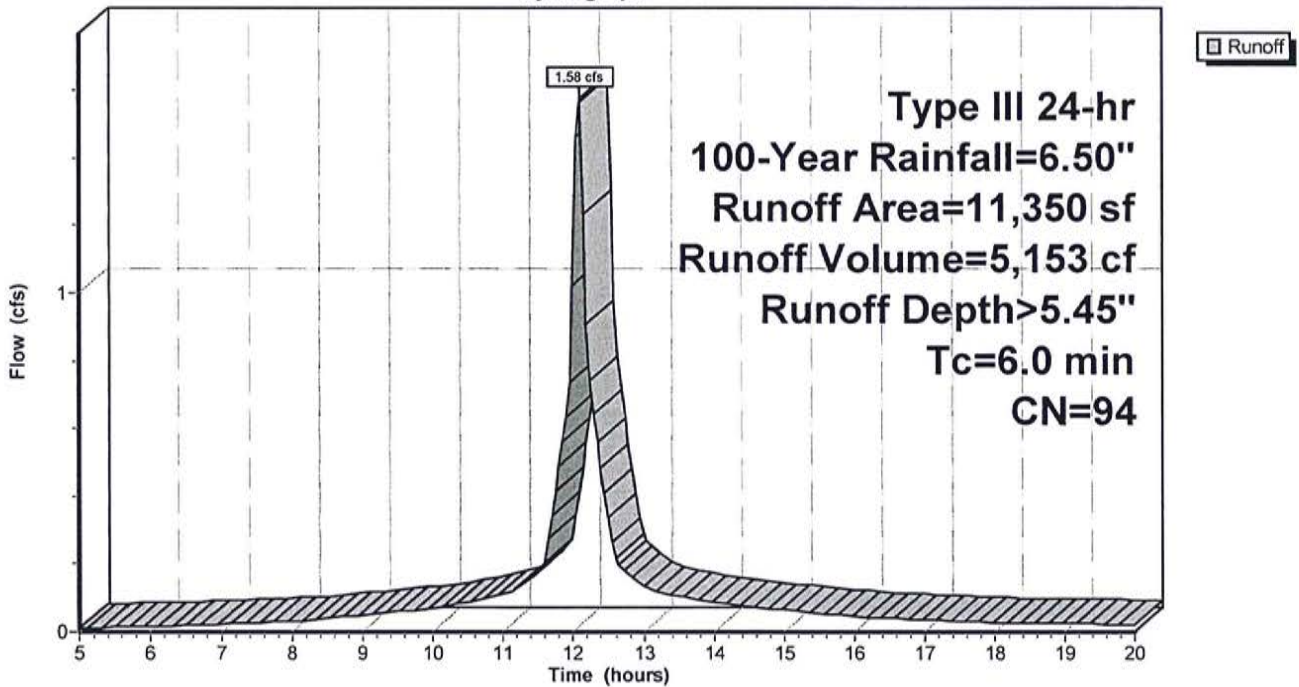

Summary for Subcatchment 2S: Area 2S

Runoff = 1.15 cfs @ 12.00 hrs, Volume= 3,235 cf, Depth> 5.55"

Runoff by SCS TR-20 method, UH=SCS, Weighted-CN, Time Span= 5.00-20.00 hrs, dt= 0.05 hrs
 Type III 24-hr 100-Year Rainfall=6.50"

Area (sf)	CN	Description
6,625	98	Paved parking, HSG A
375	39	>75% Grass cover, Good, HSG A
7,000	95	Weighted Average
375		5.36% Pervious Area
6,625		94.64% Impervious Area

Subcatchment 2S: Area 2S

Hydrograph

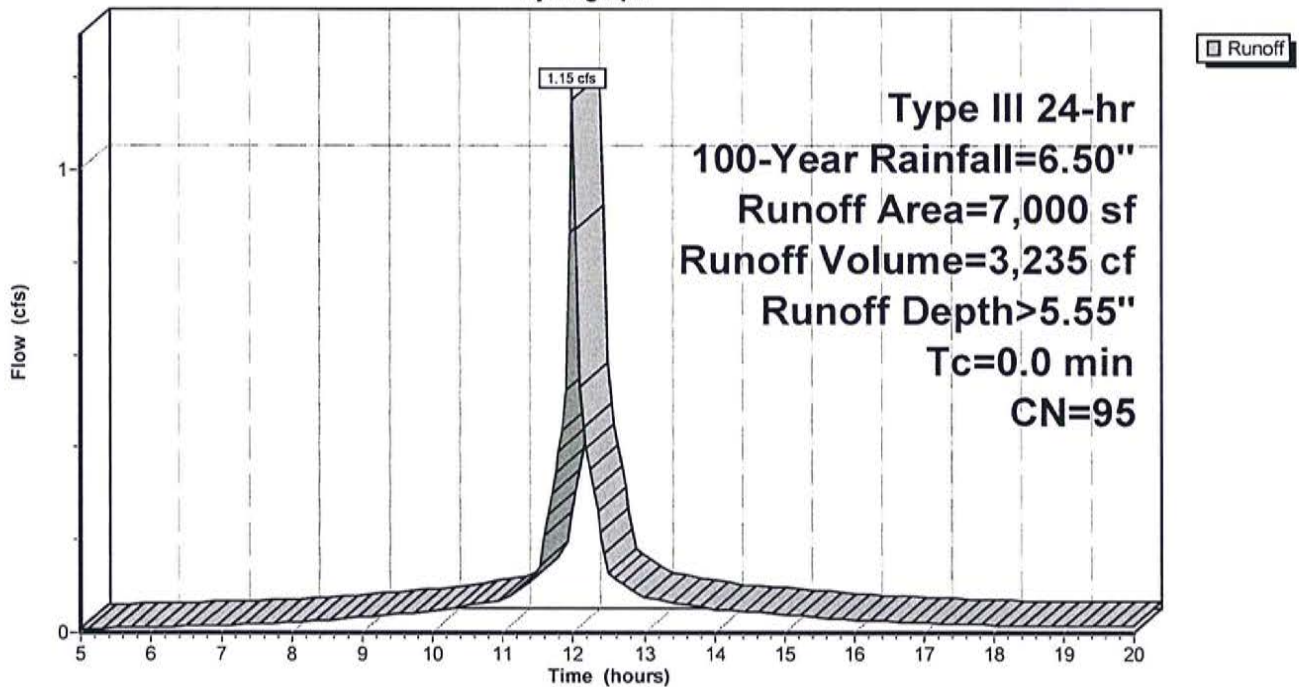

Post-Dev

Prepared by Millennium Engineering, Inc.
 HydroCAD® 10.00-25 s/n 02736 © 2019 HydroCAD Software Solutions LLC

Type III 24-hr 100-Year Rainfall=6.50"

Printed 8/27/2020

Page 34

Summary for Subcatchment 3S: Area 3S

Runoff = 0.43 cfs @ 12.09 hrs, Volume= 1,446 cf, Depth> 5.78"

Runoff by SCS TR-20 method, UH=SCS, Weighted-CN, Time Span= 5.00-20.00 hrs, dt= 0.05 hrs
 Type III 24-hr 100-Year Rainfall=6.50"

Area (sf)	CN	Description
3,000	98	Roofs, HSG A
3,000		100.00% Impervious Area

Tc (min)	Length (feet)	Slope (ft/ft)	Velocity (ft/sec)	Capacity (cfs)	Description
6.0					Direct Entry,

Subcatchment 3S: Area 3S

Hydrograph

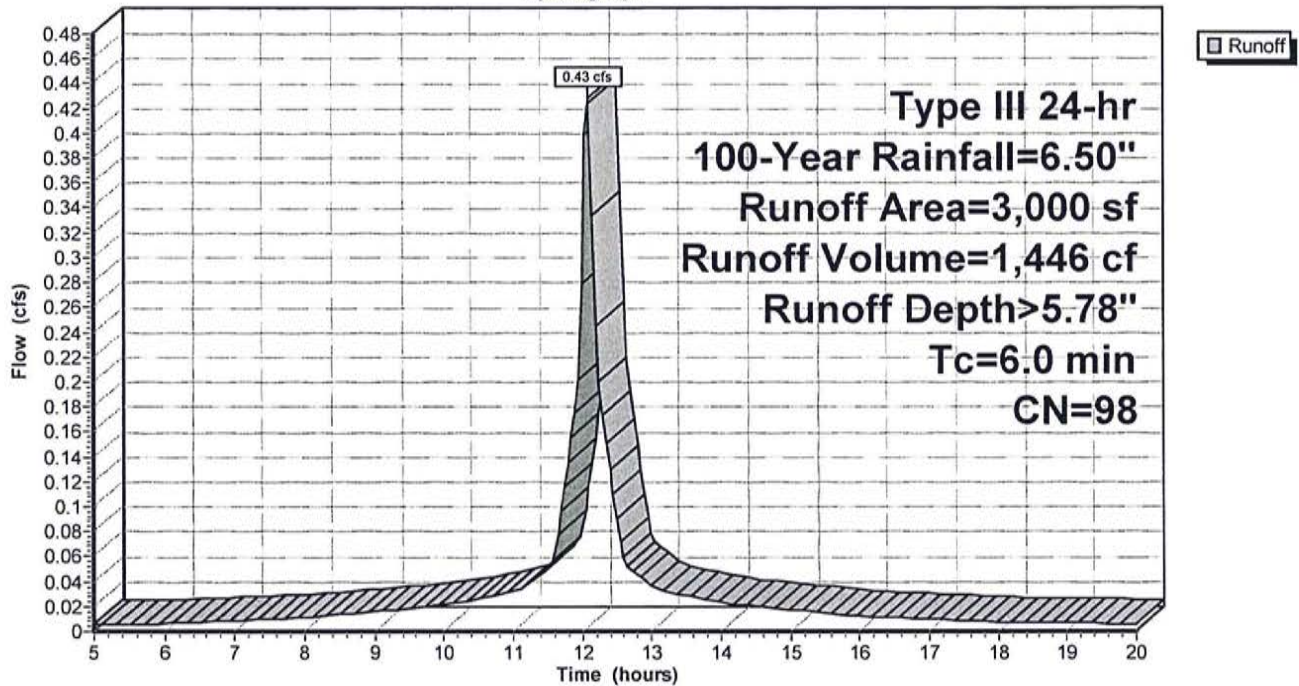

Post-Dev

Prepared by Millennium Engineering, Inc.

HydroCAD® 10.00-25 s/n 02736 © 2019 HydroCAD Software Solutions LLC

Type III 24-hr 100-Year Rainfall=6.50"

Printed 8/27/2020

Page 35

Summary for Subcatchment 4S: Area 4S

Runoff = 0.04 cfs @ 12.29 hrs, Volume= 265 cf, Depth> 0.51"

Runoff by SCS TR-20 method, UH=SCS, Weighted-CN, Time Span= 5.00-20.00 hrs, dt= 0.05 hrs
 Type III 24-hr 100-Year Rainfall=6.50"

Area (sf)	CN	Description
6,250	39	>75% Grass cover, Good, HSG A
6,250		100.00% Pervious Area

Tc (min)	Length (feet)	Slope (ft/ft)	Velocity (ft/sec)	Capacity (cfs)	Description
6.0					Direct Entry,

Subcatchment 4S: Area 4S

Hydrograph

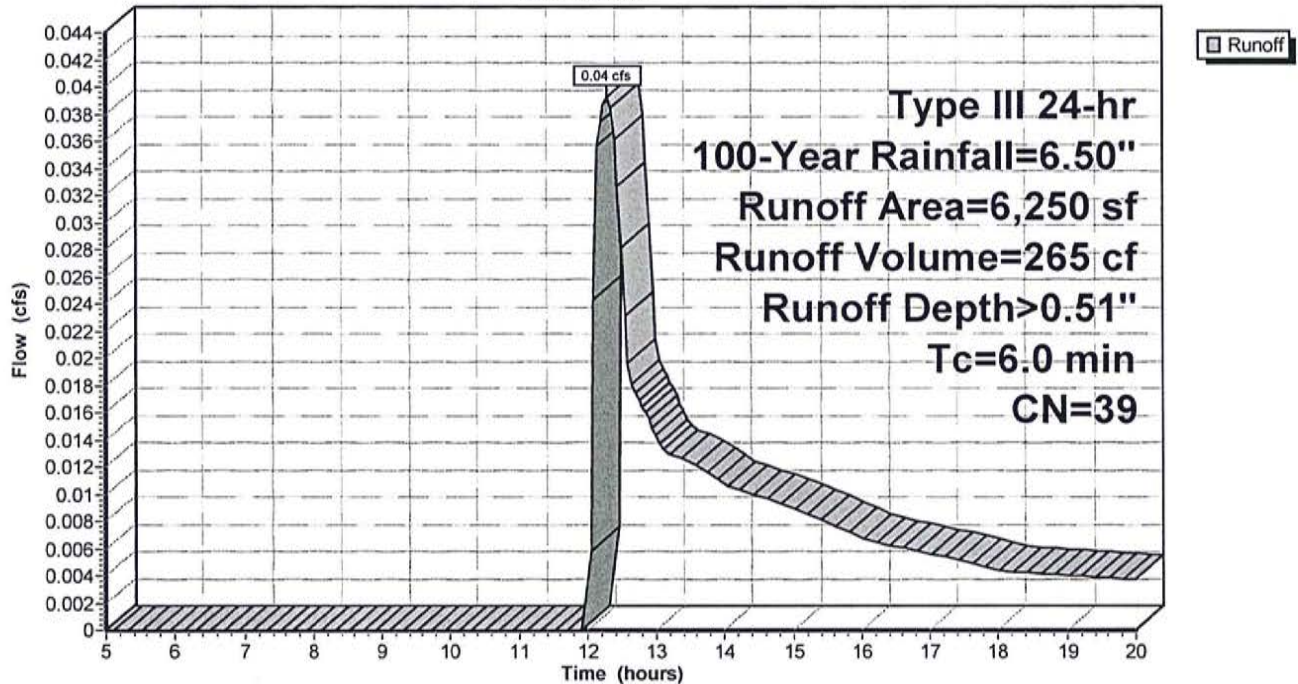

Summary for Subcatchment 100S: Area 100S

Runoff = 0.04 cfs @ 12.32 hrs, Volume= 292 cf, Depth> 0.45"

Runoff by SCS TR-20 method, UH=SCS, Weighted-CN, Time Span= 5.00-20.00 hrs, dt= 0.05 hrs
 Type III 24-hr 100-Year Rainfall=6.50"

Area (sf)	CN	Description
7,145	39	>75% Grass cover, Good, HSG A
600	30	Woods, Good, HSG A
7,745	38	Weighted Average
7,745		100.00% Pervious Area

Tc (min)	Length (feet)	Slope (ft/ft)	Velocity (ft/sec)	Capacity (cfs)	Description
6.0					Direct Entry,

Subcatchment 100S: Area 100S

Hydrograph

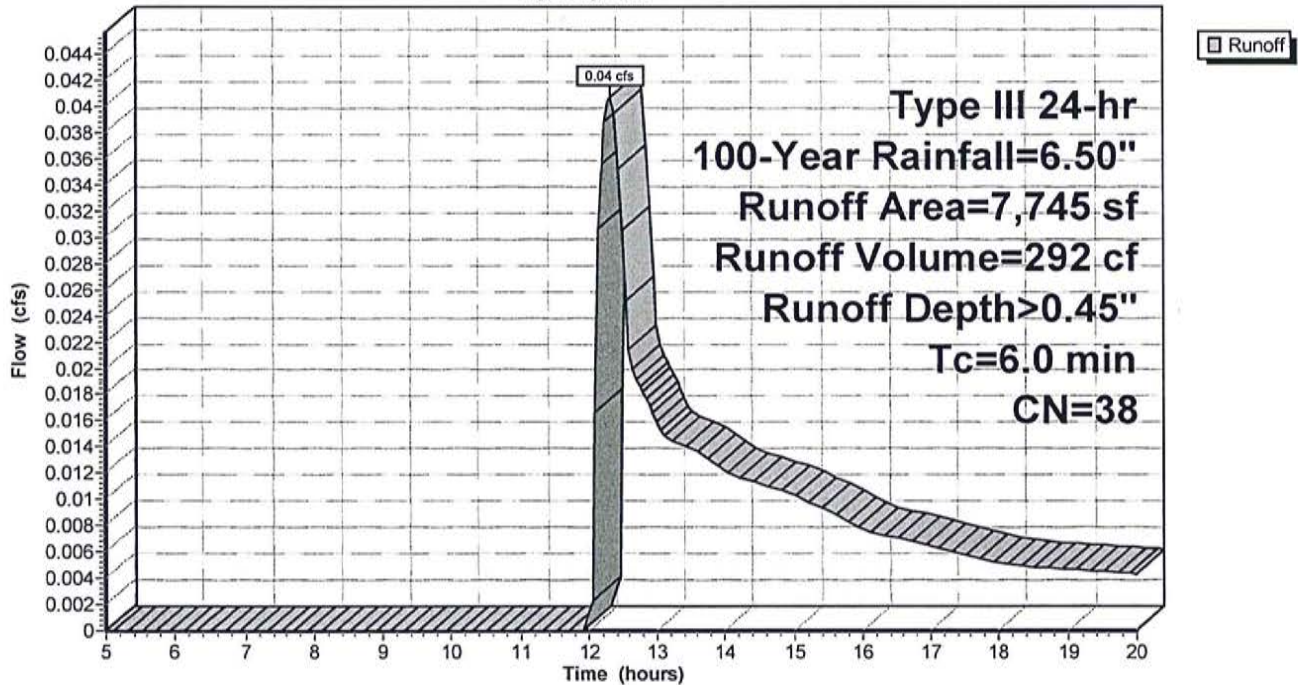

Post-Dev

Prepared by Millennium Engineering, Inc.

HydroCAD® 10.00-25 s/n 02736 © 2019 HydroCAD Software Solutions LLC

Type III 24-hr 100-Year Rainfall=6.50"

Printed 8/27/2020

Page 37

Summary for Subcatchment 200S: Area 200S

Runoff = 0.02 cfs @ 12.29 hrs, Volume= 141 cf, Depth> 0.51"

Runoff by SCS TR-20 method, UH=SCS, Weighted-CN, Time Span= 5.00-20.00 hrs, dt= 0.05 hrs
 Type III 24-hr 100-Year Rainfall=6.50"

Area (sf)	CN	Description
3,335	39	>75% Grass cover, Good, HSG A
3,335		100.00% Pervious Area

Tc (min)	Length (feet)	Slope (ft/ft)	Velocity (ft/sec)	Capacity (cfs)	Description
6.0					Direct Entry,

Subcatchment 200S: Area 200S

Hydrograph

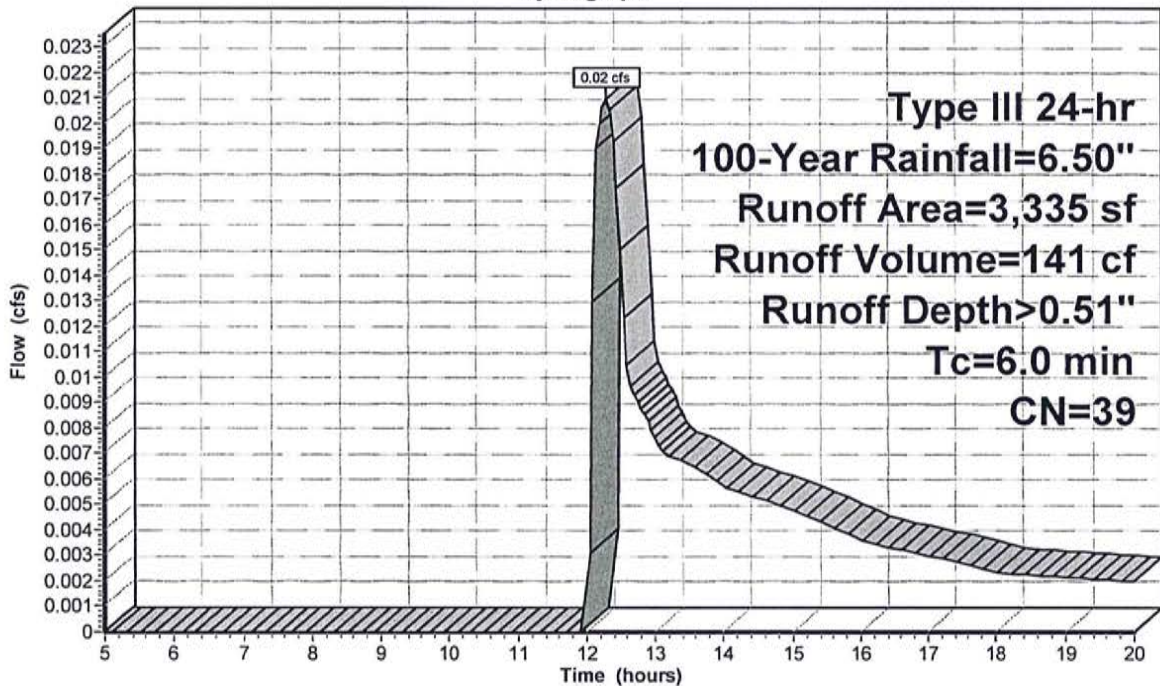

Runoff

Post-Dev

Type III 24-hr 100-Year Rainfall=6.50"

Prepared by Millennium Engineering, Inc.

Printed 8/27/2020

HydroCAD® 10.00-25 s/n 02736 © 2019 HydroCAD Software Solutions LLC

Page 38

Summary for Subcatchment 300S: Area 300S

Runoff = 0.06 cfs @ 12.10 hrs, Volume= 172 cf, Depth> 2.15"

Runoff by SCS TR-20 method, UH=SCS, Weighted-CN, Time Span= 5.00-20.00 hrs, dt= 0.05 hrs
 Type III 24-hr 100-Year Rainfall=6.50"

Area (sf)	CN	Description
610	39	>75% Grass cover, Good, HSG A
350	98	Paved parking, HSG A
960	61	Weighted Average
610		63.54% Pervious Area
350		36.46% Impervious Area

Tc (min)	Length (feet)	Slope (ft/ft)	Velocity (ft/sec)	Capacity (cfs)	Description
6.0					Direct Entry,

Subcatchment 300S: Area 300S

Hydrograph

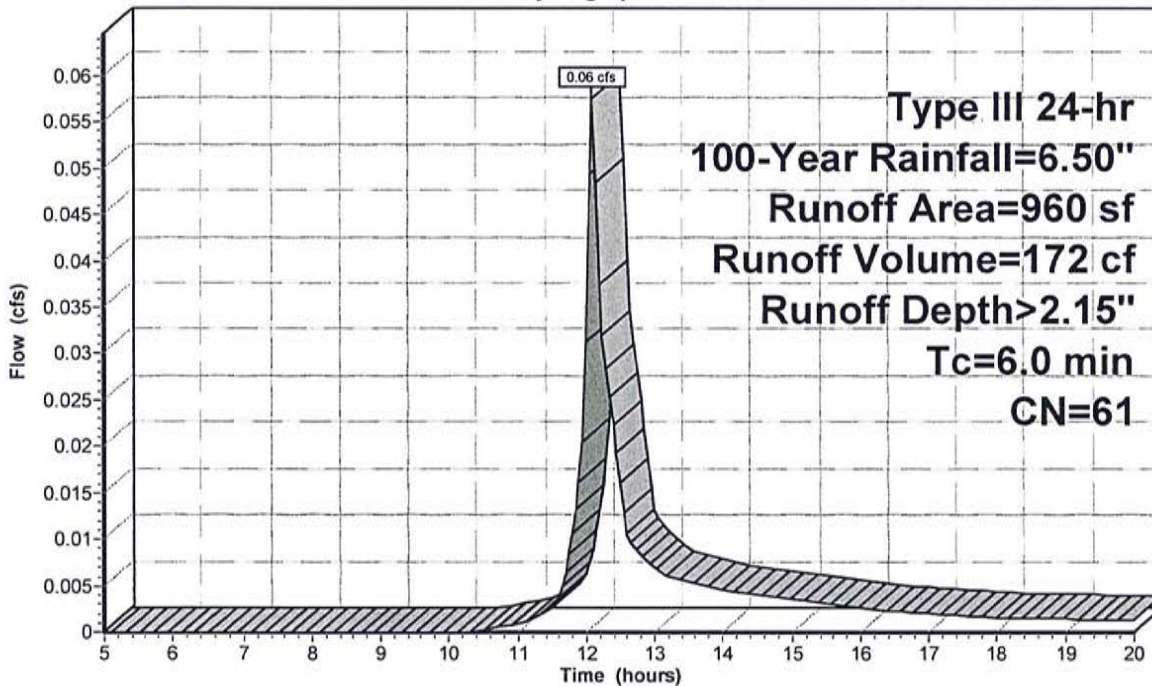

Runoff

Post-Dev

Type III 24-hr 100-Year Rainfall=6.50"

Prepared by Millennium Engineering, Inc.

Printed 8/27/2020

HydroCAD® 10.00-25 s/n 02736 © 2019 HydroCAD Software Solutions LLC

Page 39

Summary for Pond 1P: Infiltration Basin

Inflow Area = 27,600 sf, 73.46% Impervious, Inflow Depth > 4.39" for 100-Year event
 Inflow = 2.74 cfs @ 12.05 hrs, Volume= 10,099 cf
 Outflow = 1.24 cfs @ 12.28 hrs, Volume= 9,978 cf, Atten= 55%, Lag= 13.8 min
 Discarded = 0.30 cfs @ 12.28 hrs, Volume= 8,777 cf
 Primary = 0.94 cfs @ 12.28 hrs, Volume= 1,201 cf

Routing by Stor-Ind method, Time Span= 5.00-20.00 hrs, dt= 0.05 hrs
 Peak Elev= 19.09' @ 12.28 hrs Surf.Area= 3,713 sf Storage= 3,334 cf
 Flood Elev= 19.50' Surf.Area= 4,230 sf Storage= 4,976 cf

Plug-Flow detention time= 92.1 min calculated for 9,977 cf (99% of inflow)
 Center-of-Mass det. time= 86.7 min (830.3 - 743.6)

Volume	Invert	Avail.Storage	Storage Description
#1	18.00'	4,976 cf	Custom Stage Data (Prismatic) Listed below (Recalc)

Elevation (feet)	Surf.Area (sq-ft)	Inc.Store (cubic-feet)	Cum.Store (cubic-feet)
18.00	2,430	0	0
19.00	3,605	3,018	3,018
19.50	4,230	1,959	4,976

Device	Routing	Invert	Outlet Devices
#1	Discarded	18.00'	2.410 in/hr Exfiltration over Surface area Conductivity to Groundwater Elevation = 16.00'
#2	Primary	19.00'	15.0' long x 9.0' breadth Broad-Crested Rectangular Weir Head (feet) 0.20 0.40 0.60 0.80 1.00 1.20 1.40 1.60 1.80 2.00 2.50 3.00 3.50 4.00 4.50 5.00 5.50 Coef. (English) 2.46 2.55 2.70 2.69 2.68 2.68 2.67 2.64 2.64 2.64 2.65 2.64 2.65 2.65 2.66 2.67 2.69

Discarded OutFlow Max=0.30 cfs @ 12.28 hrs HW=19.09' (Free Discharge)
 ↑1=Exfiltration (Controls 0.30 cfs)

Primary OutFlow Max=0.93 cfs @ 12.28 hrs HW=19.09' (Free Discharge)
 ↑2=Broad-Crested Rectangular Weir (Weir Controls 0.93 cfs @ 0.72 fps)

Pond 1P: Infiltration Basin

Hydrograph

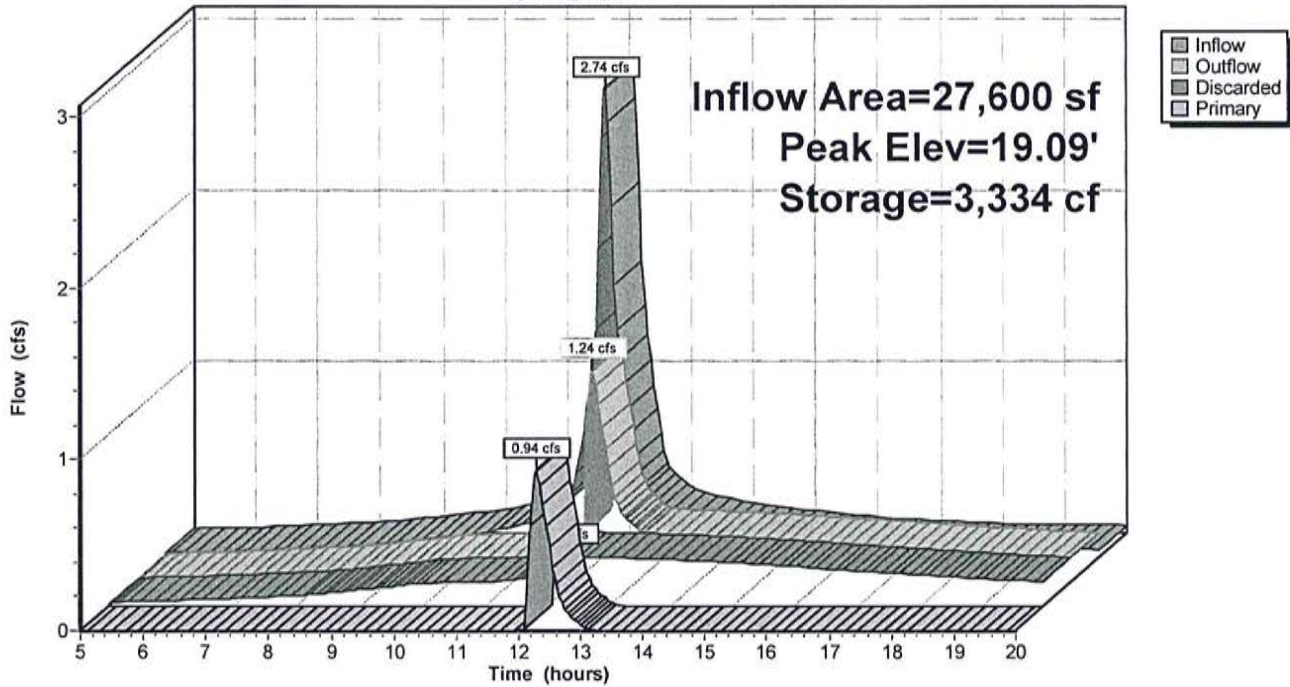

Summary for Link 100L: Pond

Inflow Area = 35,345 sf, 57.36% Impervious, Inflow Depth > 0.51" for 100-Year event
Inflow = 0.98 cfs @ 12.29 hrs, Volume= 1,493 cf
Primary = 0.98 cfs @ 12.29 hrs, Volume= 1,493 cf, Atten= 0%, Lag= 0.0 min

Primary outflow = Inflow, Time Span= 5.00-20.00 hrs, dt= 0.05 hrs

Link 100L: Pond

Hydrograph

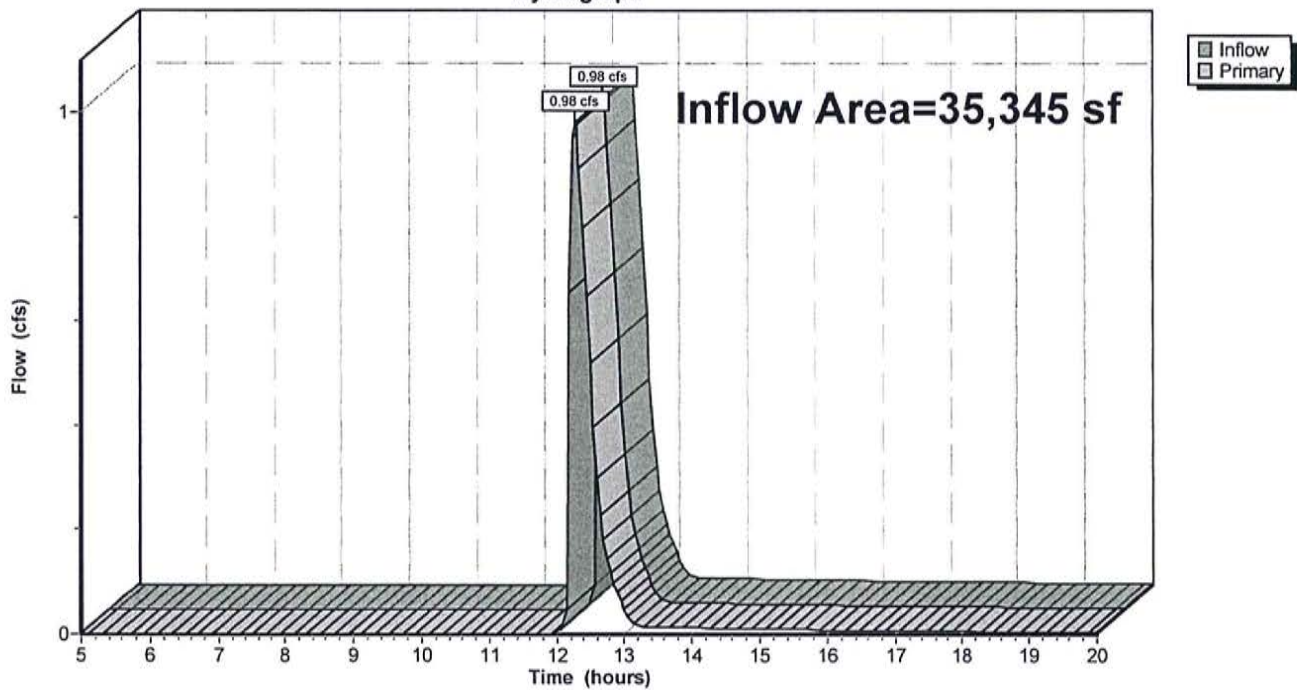

Summary for Link 200L: Wetlands

Inflow Area = 3,335 sf, 0.00% Impervious, Inflow Depth > 0.51" for 100-Year event
Inflow = 0.02 cfs @ 12.29 hrs, Volume= 141 cf
Primary = 0.02 cfs @ 12.29 hrs, Volume= 141 cf, Atten= 0%, Lag= 0.0 min

Primary outflow = Inflow, Time Span= 5.00-20.00 hrs, dt= 0.05 hrs

Link 200L: Wetlands

Hydrograph

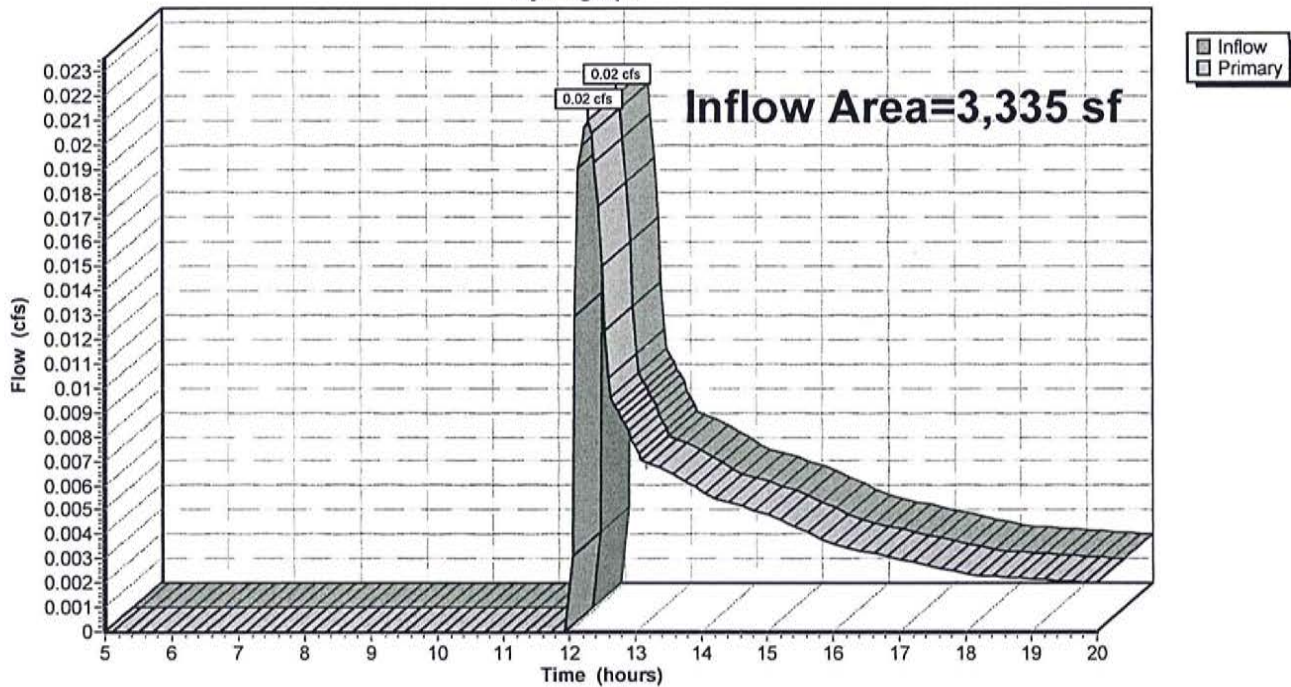

Summary for Link 300L: Route 1

Inflow Area = 960 sf, 36.46% Impervious, Inflow Depth > 2.15" for 100-Year event
Inflow = 0.06 cfs @ 12.10 hrs, Volume= 172 cf
Primary = 0.06 cfs @ 12.10 hrs, Volume= 172 cf, Atten= 0%, Lag= 0.0 min

Primary outflow = Inflow, Time Span= 5.00-20.00 hrs, dt= 0.05 hrs

Link 300L: Route 1

Hydrograph

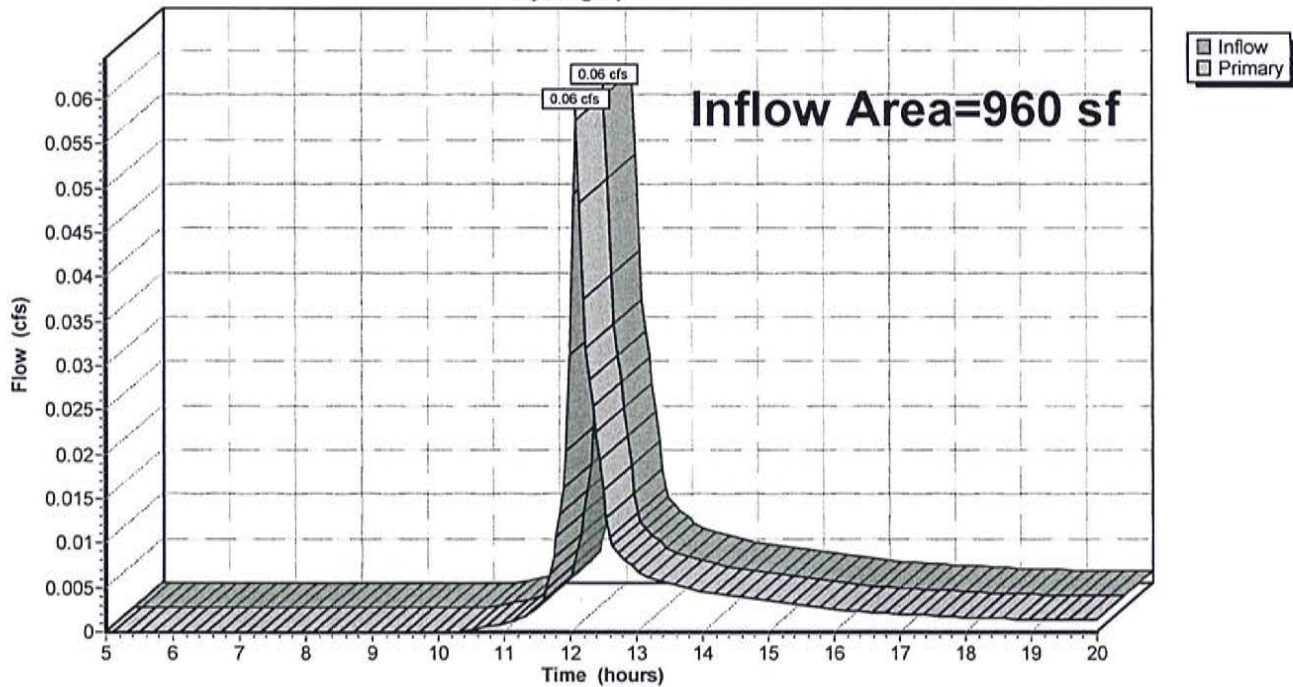

12.0 APPENDIX E – NRCS SOIL MAP

Custom Soil Resource Report for Essex County, Massachusetts, Northern Part

3 Newburyport Turnpike

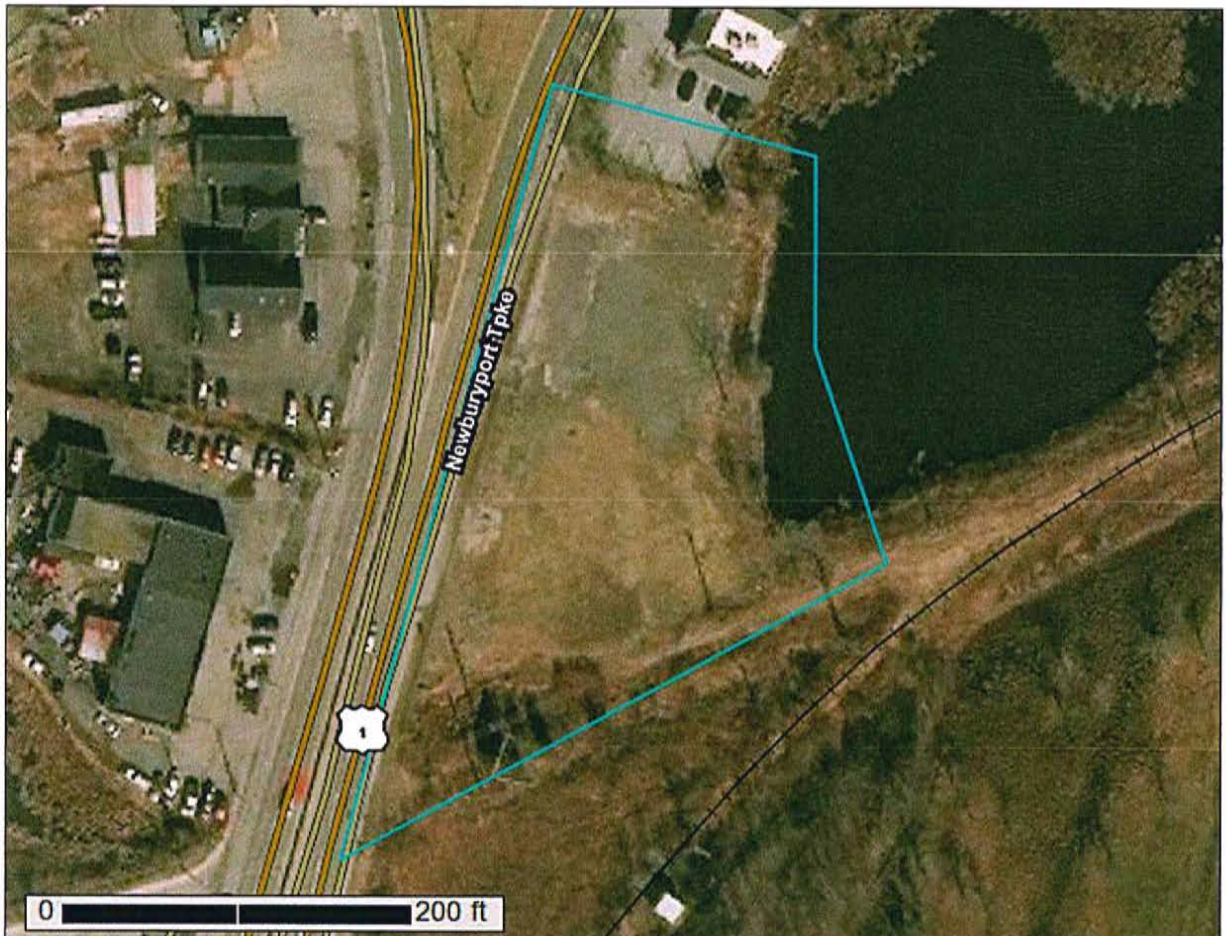

Preface

Soil surveys contain information that affects land use planning in survey areas. They highlight soil limitations that affect various land uses and provide information about the properties of the soils in the survey areas. Soil surveys are designed for many different users, including farmers, ranchers, foresters, agronomists, urban planners, community officials, engineers, developers, builders, and home buyers. Also, conservationists, teachers, students, and specialists in recreation, waste disposal, and pollution control can use the surveys to help them understand, protect, or enhance the environment.

Various land use regulations of Federal, State, and local governments may impose special restrictions on land use or land treatment. Soil surveys identify soil properties that are used in making various land use or land treatment decisions. The information is intended to help the land users identify and reduce the effects of soil limitations on various land uses. The landowner or user is responsible for identifying and complying with existing laws and regulations.

Although soil survey information can be used for general farm, local, and wider area planning, onsite investigation is needed to supplement this information in some cases. Examples include soil quality assessments (<http://www.nrcs.usda.gov/wps/portal/nrcs/main/soils/health/>) and certain conservation and engineering applications. For more detailed information, contact your local USDA Service Center (<https://offices.sc.egov.usda.gov/locator/app?agency=nrcs>) or your NRCS State Soil Scientist (http://www.nrcs.usda.gov/wps/portal/nrcs/detail/soils/contactus/?cid=nrcs142p2_053951).

Great differences in soil properties can occur within short distances. Some soils are seasonally wet or subject to flooding. Some are too unstable to be used as a foundation for buildings or roads. Clayey or wet soils are poorly suited to use as septic tank absorption fields. A high water table makes a soil poorly suited to basements or underground installations.

The National Cooperative Soil Survey is a joint effort of the United States Department of Agriculture and other Federal agencies, State agencies including the Agricultural Experiment Stations, and local agencies. The Natural Resources Conservation Service (NRCS) has leadership for the Federal part of the National Cooperative Soil Survey.

Information about soils is updated periodically. Updated information is available through the NRCS Web Soil Survey, the site for official soil survey information.

The U.S. Department of Agriculture (USDA) prohibits discrimination in all its programs and activities on the basis of race, color, national origin, age, disability, and where applicable, sex, marital status, familial status, parental status, religion, sexual orientation, genetic information, political beliefs, reprisal, or because all or a part of an individual's income is derived from any public assistance program. (Not all prohibited bases apply to all programs.) Persons with disabilities who require

alternative means for communication of program information (Braille, large print, audiotape, etc.) should contact USDA's TARGET Center at (202) 720-2600 (voice and TDD). To file a complaint of discrimination, write to USDA, Director, Office of Civil Rights, 1400 Independence Avenue, S.W., Washington, D.C. 20250-9410 or call (800) 795-3272 (voice) or (202) 720-6382 (TDD). USDA is an equal opportunity provider and employer.

Contents

Preface	2
How Soil Surveys Are Made	5
Soil Map	8
Soil Map.....	9
Legend.....	10
Map Unit Legend.....	11
Map Unit Descriptions.....	11
Essex County, Massachusetts, Northern Part.....	13
16A—Scantic silt loam, 0 to 3 percent slopes.....	13
52A—Freetown muck, 0 to 1 percent slopes.....	14
651—Udorthents, smoothed.....	15
Soil Information for All Uses	17
Soil Properties and Qualities.....	17
Soil Qualities and Features.....	17
Hydrologic Soil Group.....	17

How Soil Surveys Are Made

Soil surveys are made to provide information about the soils and miscellaneous areas in a specific area. They include a description of the soils and miscellaneous areas and their location on the landscape and tables that show soil properties and limitations affecting various uses. Soil scientists observed the steepness, length, and shape of the slopes; the general pattern of drainage; the kinds of crops and native plants; and the kinds of bedrock. They observed and described many soil profiles. A soil profile is the sequence of natural layers, or horizons, in a soil. The profile extends from the surface down into the unconsolidated material in which the soil formed or from the surface down to bedrock. The unconsolidated material is devoid of roots and other living organisms and has not been changed by other biological activity.

Currently, soils are mapped according to the boundaries of major land resource areas (MLRAs). MLRAs are geographically associated land resource units that share common characteristics related to physiography, geology, climate, water resources, soils, biological resources, and land uses (USDA, 2006). Soil survey areas typically consist of parts of one or more MLRA.

The soils and miscellaneous areas in a survey area occur in an orderly pattern that is related to the geology, landforms, relief, climate, and natural vegetation of the area. Each kind of soil and miscellaneous area is associated with a particular kind of landform or with a segment of the landform. By observing the soils and miscellaneous areas in the survey area and relating their position to specific segments of the landform, a soil scientist develops a concept, or model, of how they were formed. Thus, during mapping, this model enables the soil scientist to predict with a considerable degree of accuracy the kind of soil or miscellaneous area at a specific location on the landscape.

Commonly, individual soils on the landscape merge into one another as their characteristics gradually change. To construct an accurate soil map, however, soil scientists must determine the boundaries between the soils. They can observe only a limited number of soil profiles. Nevertheless, these observations, supplemented by an understanding of the soil-vegetation-landscape relationship, are sufficient to verify predictions of the kinds of soil in an area and to determine the boundaries.

Soil scientists recorded the characteristics of the soil profiles that they studied. They noted soil color, texture, size and shape of soil aggregates, kind and amount of rock fragments, distribution of plant roots, reaction, and other features that enable them to identify soils. After describing the soils in the survey area and determining their properties, the soil scientists assigned the soils to taxonomic classes (units). Taxonomic classes are concepts. Each taxonomic class has a set of soil characteristics with precisely defined limits. The classes are used as a basis for comparison to classify soils systematically. Soil taxonomy, the system of taxonomic classification used in the United States, is based mainly on the kind and character of soil properties and the arrangement of horizons within the profile. After the soil

Custom Soil Resource Report

scientists classified and named the soils in the survey area, they compared the individual soils with similar soils in the same taxonomic class in other areas so that they could confirm data and assemble additional data based on experience and research.

The objective of soil mapping is not to delineate pure map unit components; the objective is to separate the landscape into landforms or landform segments that have similar use and management requirements. Each map unit is defined by a unique combination of soil components and/or miscellaneous areas in predictable proportions. Some components may be highly contrasting to the other components of the map unit. The presence of minor components in a map unit in no way diminishes the usefulness or accuracy of the data. The delineation of such landforms and landform segments on the map provides sufficient information for the development of resource plans. If intensive use of small areas is planned, onsite investigation is needed to define and locate the soils and miscellaneous areas.

Soil scientists make many field observations in the process of producing a soil map. The frequency of observation is dependent upon several factors, including scale of mapping, intensity of mapping, design of map units, complexity of the landscape, and experience of the soil scientist. Observations are made to test and refine the soil-landscape model and predictions and to verify the classification of the soils at specific locations. Once the soil-landscape model is refined, a significantly smaller number of measurements of individual soil properties are made and recorded. These measurements may include field measurements, such as those for color, depth to bedrock, and texture, and laboratory measurements, such as those for content of sand, silt, clay, salt, and other components. Properties of each soil typically vary from one point to another across the landscape.

Observations for map unit components are aggregated to develop ranges of characteristics for the components. The aggregated values are presented. Direct measurements do not exist for every property presented for every map unit component. Values for some properties are estimated from combinations of other properties.

While a soil survey is in progress, samples of some of the soils in the area generally are collected for laboratory analyses and for engineering tests. Soil scientists interpret the data from these analyses and tests as well as the field-observed characteristics and the soil properties to determine the expected behavior of the soils under different uses. Interpretations for all of the soils are field tested through observation of the soils in different uses and under different levels of management. Some interpretations are modified to fit local conditions, and some new interpretations are developed to meet local needs. Data are assembled from other sources, such as research information, production records, and field experience of specialists. For example, data on crop yields under defined levels of management are assembled from farm records and from field or plot experiments on the same kinds of soil.

Predictions about soil behavior are based not only on soil properties but also on such variables as climate and biological activity. Soil conditions are predictable over long periods of time, but they are not predictable from year to year. For example, soil scientists can predict with a fairly high degree of accuracy that a given soil will have a high water table within certain depths in most years, but they cannot predict that a high water table will always be at a specific level in the soil on a specific date.

After soil scientists located and identified the significant natural bodies of soil in the survey area, they drew the boundaries of these bodies on aerial photographs and

Custom Soil Resource Report

identified each as a specific map unit. Aerial photographs show trees, buildings, fields, roads, and rivers, all of which help in locating boundaries accurately.

Soil Map

The soil map section includes the soil map for the defined area of interest, a list of soil map units on the map and extent of each map unit, and cartographic symbols displayed on the map. Also presented are various metadata about data used to produce the map, and a description of each soil map unit.

Custom Soil Resource Report
Soil Map



Soil Map may not be valid at this scale.

























Map Scale: 1:794 if printed on A portrait (8.5" x 11") sheet.

0 10 20 40 60 Meters

0 35 70 140 210 Feet

Map projection: Web Mercator Corner coordinates: WGS84 Edge ticks: UTM Zone 19N WGS84

MAP LEGEND

-  Area of Interest (AOI)
-  Area of Interest (AOI)
- Soils**
-  Soil Map Unit Polygons
-  Soil Map Unit Lines
-  Soil Map Unit Points
- Special Point Features**
-  Blowout
-  Borrow Pit
-  Clay Spot
-  Closed Depression
-  Gravel Pit
-  Gravelly Spot
-  Landfill
-  Lava Flow
-  Marsh or swamp
-  Mine or Quarry
-  Miscellaneous Water
-  Perennial Water
-  Rock Outcrop
-  Saline Spot
-  Sandy Spot
-  Severely Eroded Spot
-  Sinkhole
-  Slide or Slip
-  Sodic Spot
-  Spoil Area
-  Stony Spot
-  Very Stony Spot
-  Wet Spot
-  Other
-  Special Line Features
- Water Features**
-  Streams and Canals
- Transportation**
-  Rails
-  Interstate Highways
-  US Routes
-  Major Roads
-  Local Roads
- Background**
-  Aerial Photography

MAP INFORMATION

The soil surveys that comprise your AOI were mapped at 1:15,800.

Warning: Soil Map may not be valid at this scale.

Enlargement of maps beyond the scale of mapping can cause misunderstanding of the detail of mapping and accuracy of soil line placement. The maps do not show the small areas of contrasting soils that could have been shown at a more detailed scale.

Please rely on the bar scale on each map sheet for map measurements.

Source of Map: Natural Resources Conservation Service
 Web Soil Survey URL:
 Coordinate System: Web Mercator (EPSG:3857)

Maps from the Web Soil Survey are based on the Web Mercator projection, which preserves direction and shape but distorts distance and area. A projection that preserves area, such as the Albers equal-area conic projection, should be used if more accurate calculations of distance or area are required.

This product is generated from the USDA-NRCS certified data as of the version date(s) listed below.

Soil Survey Area: Essex County, Massachusetts, Northern Part
 Survey Area Data: Version 15, Sep 12, 2019

Soil map units are labeled (as space allows) for map scales 1:50,000 or larger.

Date(s) aerial images were photographed: Dec 31, 2009—Sep 12, 2016

The orthophoto or other base map on which the soil lines were compiled and digitized probably differs from the background imagery displayed on these maps. As a result, some minor shifting of map unit boundaries may be evident.

Map Unit Legend

Map Unit Symbol	Map Unit Name	Acres in AOI	Percent of AOI
16A	Scantic silt loam, 0 to 3 percent slopes	0.0	0.3%
52A	Freetown muck, 0 to 1 percent slopes	0.7	41.7%
651	Udorhents, smoothed	1.0	58.0%
Totals for Area of Interest		1.7	100.0%

Map Unit Descriptions

The map units delineated on the detailed soil maps in a soil survey represent the soils or miscellaneous areas in the survey area. The map unit descriptions, along with the maps, can be used to determine the composition and properties of a unit.

A map unit delineation on a soil map represents an area dominated by one or more major kinds of soil or miscellaneous areas. A map unit is identified and named according to the taxonomic classification of the dominant soils. Within a taxonomic class there are precisely defined limits for the properties of the soils. On the landscape, however, the soils are natural phenomena, and they have the characteristic variability of all natural phenomena. Thus, the range of some observed properties may extend beyond the limits defined for a taxonomic class. Areas of soils of a single taxonomic class rarely, if ever, can be mapped without including areas of other taxonomic classes. Consequently, every map unit is made up of the soils or miscellaneous areas for which it is named and some minor components that belong to taxonomic classes other than those of the major soils.

Most minor soils have properties similar to those of the dominant soil or soils in the map unit, and thus they do not affect use and management. These are called noncontrasting, or similar, components. They may or may not be mentioned in a particular map unit description. Other minor components, however, have properties and behavioral characteristics divergent enough to affect use or to require different management. These are called contrasting, or dissimilar, components. They generally are in small areas and could not be mapped separately because of the scale used. Some small areas of strongly contrasting soils or miscellaneous areas are identified by a special symbol on the maps. If included in the database for a given area, the contrasting minor components are identified in the map unit descriptions along with some characteristics of each. A few areas of minor components may not have been observed, and consequently they are not mentioned in the descriptions, especially where the pattern was so complex that it was impractical to make enough observations to identify all the soils and miscellaneous areas on the landscape.

The presence of minor components in a map unit in no way diminishes the usefulness or accuracy of the data. The objective of mapping is not to delineate pure taxonomic classes but rather to separate the landscape into landforms or landform segments that have similar use and management requirements. The

Custom Soil Resource Report

delineation of such segments on the map provides sufficient information for the development of resource plans. If intensive use of small areas is planned, however, onsite investigation is needed to define and locate the soils and miscellaneous areas.

An identifying symbol precedes the map unit name in the map unit descriptions. Each description includes general facts about the unit and gives important soil properties and qualities.

Soils that have profiles that are almost alike make up a *soil series*. Except for differences in texture of the surface layer, all the soils of a series have major horizons that are similar in composition, thickness, and arrangement.

Soils of one series can differ in texture of the surface layer, slope, stoniness, salinity, degree of erosion, and other characteristics that affect their use. On the basis of such differences, a soil series is divided into *soil phases*. Most of the areas shown on the detailed soil maps are phases of soil series. The name of a soil phase commonly indicates a feature that affects use or management. For example, Alpha silt loam, 0 to 2 percent slopes, is a phase of the Alpha series.

Some map units are made up of two or more major soils or miscellaneous areas. These map units are complexes, associations, or undifferentiated groups.

A *complex* consists of two or more soils or miscellaneous areas in such an intricate pattern or in such small areas that they cannot be shown separately on the maps. The pattern and proportion of the soils or miscellaneous areas are somewhat similar in all areas. Alpha-Beta complex, 0 to 6 percent slopes, is an example.

An *association* is made up of two or more geographically associated soils or miscellaneous areas that are shown as one unit on the maps. Because of present or anticipated uses of the map units in the survey area, it was not considered practical or necessary to map the soils or miscellaneous areas separately. The pattern and relative proportion of the soils or miscellaneous areas are somewhat similar. Alpha-Beta association, 0 to 2 percent slopes, is an example.

An *undifferentiated group* is made up of two or more soils or miscellaneous areas that could be mapped individually but are mapped as one unit because similar interpretations can be made for use and management. The pattern and proportion of the soils or miscellaneous areas in a mapped area are not uniform. An area can be made up of only one of the major soils or miscellaneous areas, or it can be made up of all of them. Alpha and Beta soils, 0 to 2 percent slopes, is an example.

Some surveys include *miscellaneous areas*. Such areas have little or no soil material and support little or no vegetation. Rock outcrop is an example.

Essex County, Massachusetts, Northern Part

16A—Scantic silt loam, 0 to 3 percent slopes

Map Unit Setting

National map unit symbol: vjrl
Elevation: 10 to 900 feet
Mean annual precipitation: 45 to 54 inches
Mean annual air temperature: 43 to 54 degrees F
Frost-free period: 145 to 240 days
Farmland classification: Not prime farmland

Map Unit Composition

Scantic and similar soils: 85 percent
Minor components: 15 percent
Estimates are based on observations, descriptions, and transects of the mapunit.

Description of Scantic

Setting

Landform: Drainageways, depressions
Landform position (two-dimensional): Toeslope
Landform position (three-dimensional): Dip
Down-slope shape: Concave
Across-slope shape: Concave
Parent material: Soft fine-silty glaciolacustrine deposits and/or soft fine-silty glaciomarine deposits over hard fine-silty glaciolacustrine deposits and/or hard fine-silty glaciomarine deposits

Typical profile

H1 - 0 to 11 inches: silt loam
H2 - 11 to 26 inches: silty clay loam
H3 - 26 to 60 inches: clay

Properties and qualities

Slope: 0 to 3 percent
Depth to restrictive feature: More than 80 inches
Natural drainage class: Poorly drained
Capacity of the most limiting layer to transmit water (Ksat): Very low to moderately high (0.00 to 0.20 in/hr)
Depth to water table: About 0 to 12 inches
Frequency of flooding: None
Frequency of ponding: None
Available water storage in profile: High (about 9.6 inches)

Interpretive groups

Land capability classification (irrigated): None specified
Land capability classification (nonirrigated): 3w
Hydrologic Soil Group: C/D
Hydric soil rating: Yes

Minor Components

Maybid

Percent of map unit: 10 percent
Landform: Depressions

Custom Soil Resource Report

Hydric soil rating: Yes

Buxton

Percent of map unit: 5 percent

Hydric soil rating: No

52A—Freetown muck, 0 to 1 percent slopes

Map Unit Setting

National map unit symbol: 2t2q9

Elevation: 0 to 1,110 feet

Mean annual precipitation: 36 to 71 inches

Mean annual air temperature: 39 to 55 degrees F

Frost-free period: 140 to 240 days

Farmland classification: Not prime farmland

Map Unit Composition

Freetown and similar soils: 85 percent

Minor components: 15 percent

Estimates are based on observations, descriptions, and transects of the mapunit.

Description of Freetown

Setting

Landform: Marshes, kettles, depressions, depressions, swamps, bogs

Landform position (two-dimensional): Toeslope

Landform position (three-dimensional): Tread, dip

Down-slope shape: Concave

Across-slope shape: Concave

Parent material: Highly decomposed organic material

Typical profile

Oe - 0 to 2 inches: mucky peat

Oa - 2 to 79 inches: muck

Properties and qualities

Slope: 0 to 1 percent

Percent of area covered with surface fragments: 0.0 percent

Depth to restrictive feature: More than 80 inches

Natural drainage class: Very poorly drained

Runoff class: Negligible

Capacity of the most limiting layer to transmit water (Ksat): Moderately low to high
(0.14 to 14.17 in/hr)

Depth to water table: About 0 to 6 inches

Frequency of flooding: Rare

Frequency of ponding: Frequent

Available water storage in profile: Very high (about 19.2 inches)

Interpretive groups

Land capability classification (irrigated): None specified

Land capability classification (nonirrigated): 5w

Custom Soil Resource Report

Hydrologic Soil Group: B/D
Hydric soil rating: Yes

Minor Components

Swansea

Percent of map unit: 5 percent
Landform: Swamps, kettles, depressions, depressions, marshes, bogs
Landform position (two-dimensional): Toeslope
Landform position (three-dimensional): Tread, dip
Down-slope shape: Concave
Across-slope shape: Concave
Hydric soil rating: Yes

Scarboro

Percent of map unit: 5 percent
Landform: Drainageways, depressions
Landform position (two-dimensional): Toeslope
Landform position (three-dimensional): Base slope, tread, dip
Down-slope shape: Concave
Across-slope shape: Concave
Hydric soil rating: Yes

Whitman

Percent of map unit: 5 percent
Landform: Drainageways, depressions
Landform position (two-dimensional): Toeslope
Landform position (three-dimensional): Base slope
Down-slope shape: Concave
Across-slope shape: Concave
Hydric soil rating: Yes

651—Udorthents, smoothed

Map Unit Setting

National map unit symbol: vjwk
Elevation: 0 to 3,000 feet
Mean annual precipitation: 45 to 54 inches
Mean annual air temperature: 43 to 54 degrees F
Frost-free period: 145 to 240 days
Farmland classification: Not prime farmland

Map Unit Composition

Udorthents and similar soils: 80 percent
Minor components: 20 percent
Estimates are based on observations, descriptions, and transects of the mapunit.

Description of Udorthents

Setting

Parent material: Excavated and filled land loamy and/or excavated and filled land sandy and gravelly

Typical profile

H1 - 0 to 6 inches: variable

H2 - 6 to 60 inches: variable

Properties and qualities

Slope: 0 to 3 percent

Depth to restrictive feature: More than 80 inches

Capacity of the most limiting layer to transmit water (Ksat): Moderately low to very high (0.06 to 20.00 in/hr)

Depth to water table: More than 80 inches

Frequency of flooding: None

Frequency of ponding: None

Interpretive groups

Land capability classification (irrigated): None specified

Land capability classification (nonirrigated): 6s

Hydrologic Soil Group: A

Hydric soil rating: Unranked

Minor Components

Urban land

Percent of map unit: 10 percent

Hydric soil rating: Unranked

Beaches

Percent of map unit: 8 percent

Hydric soil rating: Unranked

Dumps

Percent of map unit: 2 percent

Hydric soil rating: Unranked

Soil Information for All Uses

Soil Properties and Qualities

The Soil Properties and Qualities section includes various soil properties and qualities displayed as thematic maps with a summary table for the soil map units in the selected area of interest. A single value or rating for each map unit is generated by aggregating the interpretive ratings of individual map unit components. This aggregation process is defined for each property or quality.

Soil Qualities and Features

Soil qualities are behavior and performance attributes that are not directly measured, but are inferred from observations of dynamic conditions and from soil properties. Example soil qualities include natural drainage, and frost action. Soil features are attributes that are not directly part of the soil. Example soil features include slope and depth to restrictive layer. These features can greatly impact the use and management of the soil.

Hydrologic Soil Group

Hydrologic soil groups are based on estimates of runoff potential. Soils are assigned to one of four groups according to the rate of water infiltration when the soils are not protected by vegetation, are thoroughly wet, and receive precipitation from long-duration storms.

The soils in the United States are assigned to four groups (A, B, C, and D) and three dual classes (A/D, B/D, and C/D). The groups are defined as follows:

Group A. Soils having a high infiltration rate (low runoff potential) when thoroughly wet. These consist mainly of deep, well drained to excessively drained sands or gravelly sands. These soils have a high rate of water transmission.

Group B. Soils having a moderate infiltration rate when thoroughly wet. These consist chiefly of moderately deep or deep, moderately well drained or well drained soils that have moderately fine texture to moderately coarse texture. These soils have a moderate rate of water transmission.

Custom Soil Resource Report

Group C. Soils having a slow infiltration rate when thoroughly wet. These consist chiefly of soils having a layer that impedes the downward movement of water or soils of moderately fine texture or fine texture. These soils have a slow rate of water transmission.

Group D. Soils having a very slow infiltration rate (high runoff potential) when thoroughly wet. These consist chiefly of clays that have a high shrink-swell potential, soils that have a high water table, soils that have a claypan or clay layer at or near the surface, and soils that are shallow over nearly impervious material. These soils have a very slow rate of water transmission.

If a soil is assigned to a dual hydrologic group (A/D, B/D, or C/D), the first letter is for drained areas and the second is for undrained areas. Only the soils that in their natural condition are in group D are assigned to dual classes.

Custom Soil Resource Report
Map—Hydrologic Soil Group



Map Scale: 1:794 if printed on A portrait (8.5" x 11") sheet.

0 10 20 40 60 Meters

0 35 70 140 210 Feet

Map projection: Web Mercator Corner coordinates: WGS84 Edge tics: UTM Zone 19N WGS84

MAP LEGEND

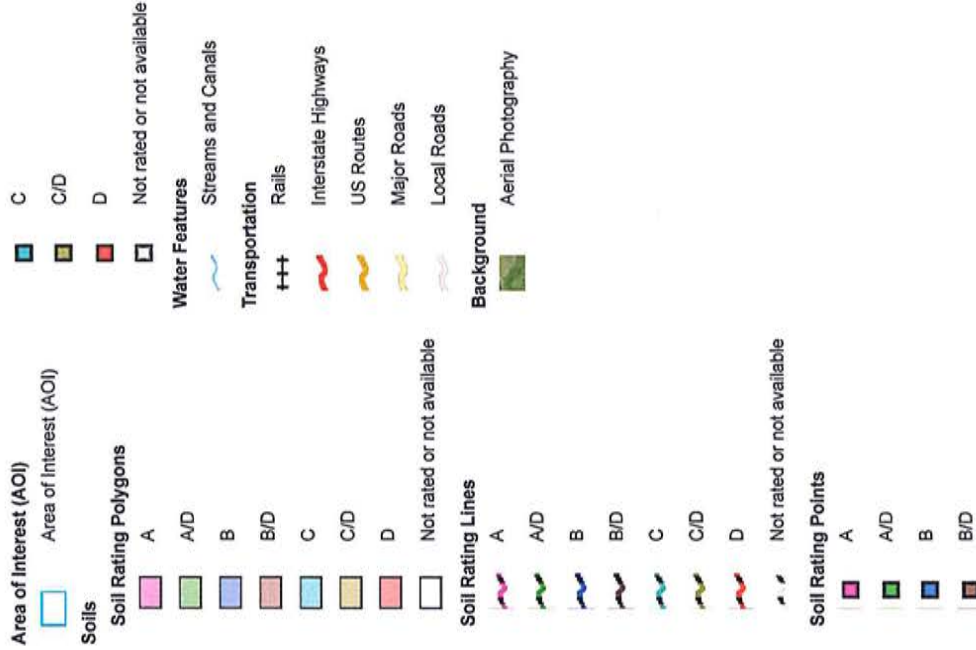

MAP INFORMATION

The soil surveys that comprise your AOI were mapped at 1:15,800.

Warning: Soil Map may not be valid at this scale.

Enlargement of maps beyond the scale of mapping can cause misunderstanding of the detail of mapping and accuracy of soil line placement. The maps do not show the small areas of contrasting soils that could have been shown at a more detailed scale.

Please rely on the bar scale on each map sheet for map measurements.

Source of Map: Natural Resources Conservation Service
 Web Soil Survey URL:
 Coordinate System: Web Mercator (EPSG:3857)

Maps from the Web Soil Survey are based on the Web Mercator projection, which preserves direction and shape but distorts distance and area. A projection that preserves area, such as the Albers equal-area conic projection, should be used if more accurate calculations of distance or area are required.

This product is generated from the USDA-NRCS certified data as of the version date(s) listed below.

Soil Survey Area: Essex County, Massachusetts, Northern Part
 Survey Area Data: Version 15, Sep 12, 2019

Soil map units are labeled (as space allows) for map scales 1:50,000 or larger.

Date(s) aerial images were photographed: Dec 31, 2009—Sep 12, 2016

The orthophoto or other base map on which the soil lines were compiled and digitized probably differs from the background imagery displayed on these maps. As a result, some minor shifting of map unit boundaries may be evident.

Table—Hydrologic Soil Group

Map unit symbol	Map unit name	Rating	Acres in AOI	Percent of AOI
16A	Scantic silt loam, 0 to 3 percent slopes	C/D	0.0	0.3%
52A	Freetown muck, 0 to 1 percent slopes	B/D	0.7	41.7%
651	Udorthents, smoothed	A	1.0	58.0%
Totals for Area of Interest			1.7	100.0%

Rating Options—Hydrologic Soil Group

Aggregation Method: Dominant Condition

Component Percent Cutoff: None Specified

Tie-break Rule: Higher

13.0 APPENDIX F – WATERSHED PLANS