

LOCUS MAP
Not to Scale

SITE DEVELOPMENT PLANS PROPOSED MEDICAL BUILDING 20 HENRY GRAF JR. ROAD IN NEWBURYPORT, MASSACHUSETTS

Drawing Index:

No.	Drawing Title
CS-1	COVER SHEET
L-1	LEGEND, ABBREVIATIONS & GENERAL NOTES
EX-1	EXISTING CONDITIONS PLAN
C-1	SITE LAYOUT PLAN
C-2	GRADING AND DRAINAGE PLAN
C-3	UTILITY PLAN
ESC-1	EROSION AND SEDIMENT CONTROL PLAN
LA-1	LANDSCAPING PLAN
D-1 - D-6	CONSTRUCTION DETAILS

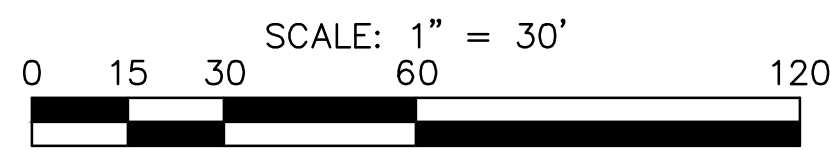
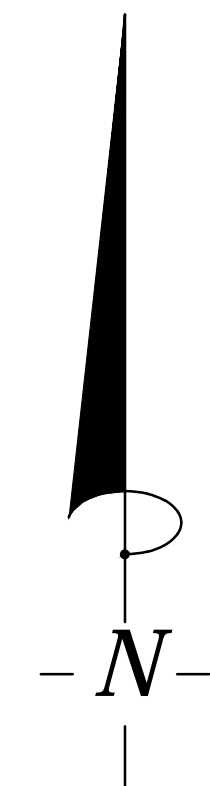
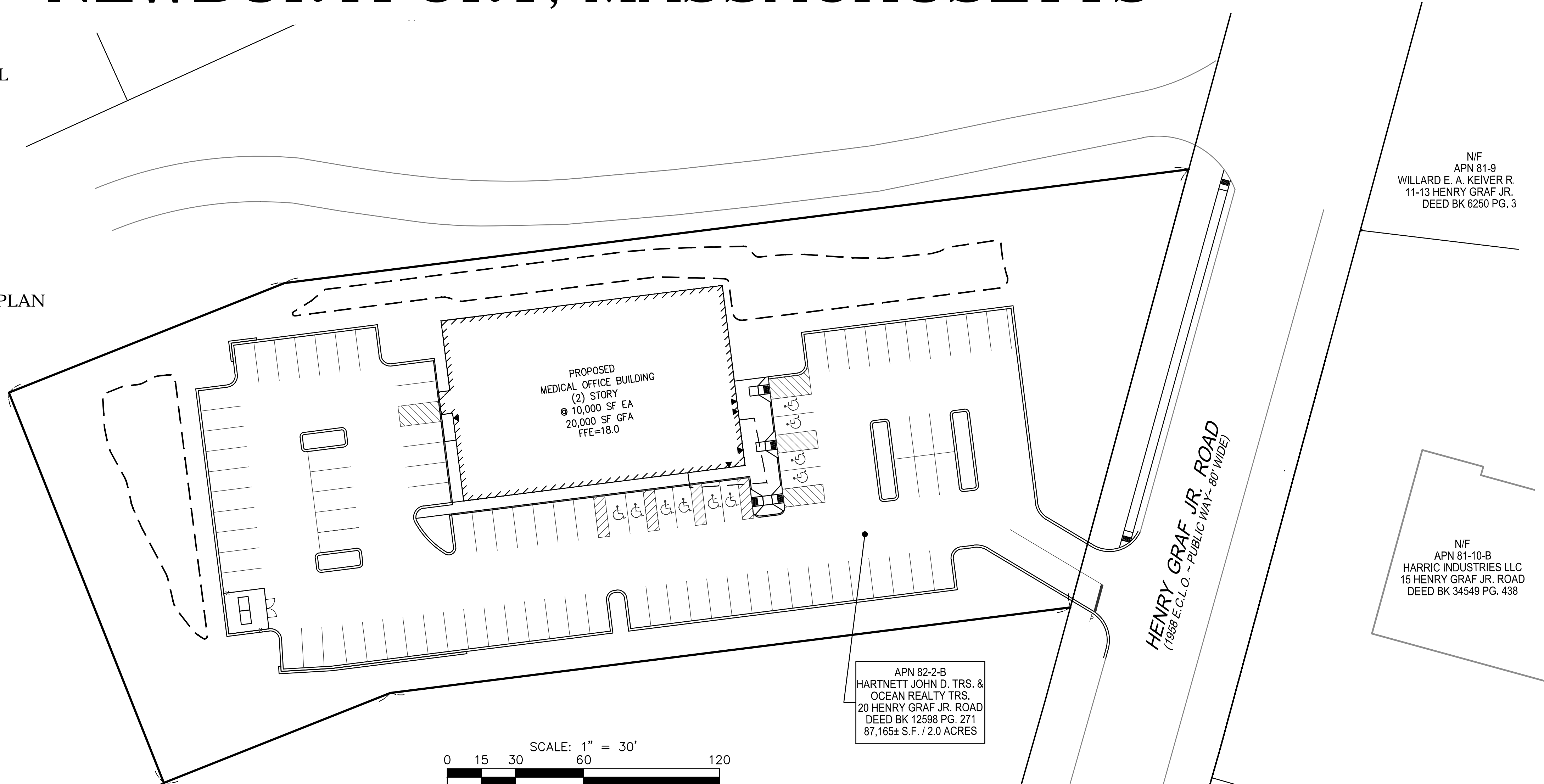

Owner:
JOHN D. HARTNETT, TRS.
OCEAN REALTY TRS.
8 GRAF ROAD
NEWBURYPORT, MASSACHUSETTS 01950

Applicant:
SPORTS MEDICINE NORTH ORTHOPEDIC SURGERY, INC.
C/O CONSERV GROUP, INC.
110 STATE ROAD
SAGAMORE BEACH, MASSACHUSETTS 02562

Engineer/Surveyor:
MCKENZIE ENGINEERING GROUP, INC.
150 LONGWATER DRIVE
SUITE 101
NORWELL, MASSACHUSETTS 02061

ISSUE DATE: MARCH 17, 2020
REVISION DATE: APRIL 29, 2020

REV	DATE	DESCRIPTION	BY	APP
1	4/29/20	REVIEW COMMENTS	ESS	BCM

MG
MCKENZIE
ENGINEERING GROUP
Assisippi Office Park
150 Longwater Drive, Suite 101
Norwell, MA 02061
P: 781.792.3900
F: 781.792.0333
www.mckeng.com

**SITE DEVELOPMENT PLANS
PROPOSED MEDICAL BUILDING
20 HENRY GRAF JR. ROAD
NEWBURYPORT, MASSACHUSETTS**

PROFESSIONAL ENGINEER:

BRADLEY C. MCKENZIE
No. 3917
Professional Engineer

APPLICANT:
SPORTS MEDICINE NORTH
ORTHOPEDIC SURGERY, INC.
C/O CONSERV GROUP, INC.
110 STATE ROAD
SAGAMORE BEACH, MASSACHUSETTS 02562

DRAWN BY:	ESS
DESIGNED BY:	ESS
CHECKED BY:	BCM
APPROVED BY:	BCM
DATE:	MARCH 17, 2020
SCALE:	1" = 30'
PROJECT NO.:	219-180
DWG. TITLE:	

COVER SHEET

DWG. NO.:
CS-1

ABBREVIATIONS

ABAN	ABANDONED
ACP	ASBESTOS CEMENT PIPE
ACR	ACCESSIBLE CURB RAMP
ADJ	ADJUST
APPROX	APPROXIMATE
ASPH	ASPHALT
ACOMP	ASPHALT COATED CORRUGATED METAL PIPE
B	BOLLARD
BD	BOUND
BLDG	BUILDING
BIT CONC	BITUMINOUS CONCRETE
BM	BENCHMARK
BS	BOTTOM OF SLOPE
CAP	CORRUGATED ALUMINUM PIPE
CB	CATCH BASIN
C&C	CUT AND CAPPED
CB/DH	CONC. BOUND/DRILL HOLE
CB/EPLP	CB/ESCUTCHEON
CCB	CAPE COD BERM
CIP	CAST IRON PIPE
CIT	CHANGE IN TYPE
C	CENTERLINE
CLF	CHAIN LINK FENCE
CO	CLEAN OUT
CONC	CONCRETE
COND	CONDUIT
CMP	CORRUGATED METAL PIPE
CPP	CORRUGATED POLYETHYLENE PIPE
CS	COMBINED SEWER
CSMH	COMBINED SEWER MANHOLE
CULV	CULVERT
Δ	DELTA ANGLE
D	DRAIN
DCB	DOUBLE CATCH BASIN
DIP	DUCTILE IRON PIPE
DMH	DRAIN MANHOLE
E	ELECTRIC
ECC	EXTRUDED CONCRETE CURB
ELEV	ELEVATION
EMH	ELECTRIC MANHOLE
E/T/C	ELECTRIC, TELEPHONE, & CABLE TV
EW	END WALL
EXIST	EXISTING
FAB	FIRE ALARM BOX
FES	FLARED END SECTION
FND	FOUND
FND	FOUNDATION
F&C	FRAME AND COVER
F&G	FRAME AND GRATE
G	GAS
GD	GROUND
GG	GAS GATE
GIP	GALVANIZED IRON PIPE
GP	GUARD POST
GS	GAS SERVICE
GR	GRAND RAIL
GRAN	GRANITE
HDPE	HIGH-DENSITY POLYETHYLENE PIPE
HH	HANDHOLE
HOR	HORIZONTAL
HP	HIGH PRESSURE
HWL	HEADWALL
HYD	HYDRANT
INV	INVERT
I.P.	IRON PIN
I.R.	IRON ROD
L	LEAD
LSA	LANDSCAPED AREA
LP	LIGHT POLE
MAX	MAXIMUM
MC	METAL COVER
MCC	MONOLITHIC CONCRETE CURB
MH	MANHOLE
MHB	MASS. HIGHWAY BOUND
MIN	MINIMUM
MLP	METAL LIGHT POLE
NIC	NOT IN CONTRACT
NTS	NOT TO SCALE
OHW	OVERHEAD WIRE
PB	PULL BOX
PE	POLYETHYLENE PIPE
P	PROPERTY LINE
PROP	PROPOSED
PVC	POLYVINYL CHLORIDE PIPE
PMT	PAVEMENT
PWW	PAVED WATER WAY
RCP	REINFORCED CONCRETE PIPE
REM	REMOVE
REMOD	REMODEL
RET	RETAIN
ROW	RIGHT OF WAY
RR	RAILROAD
R&R	REMOVE AND RESET
R&S	REMOVE AND STACK
S	SEWER
SB	STONE BOUND
SB/DH	STONE BOUND/DRILL HOLE
SCE	SLOPED GRANITE EDGING
SMH	SEWER MANHOLE
STA	STATION
SS	SEWER SERVICE
STL	STEEL
SW	SIDEWALK
T	TELEPHONE
TCB	TRAFFIC CONTROL BOX
TL	TRAFFIC LIGHT
TMH	TELEPHONE MANHOLE
Tr	TREE
TRANS	TRANSFORMER
TS	TOP OF SLOPE
TSV	TAPPING SLEEVE, VALVE AND BOX
TYP	TYPICAL
UP	UTILITY POLE
VCP	VITRIFIED CLAY PIPE
VERT	VERTICAL
VGC	VERTICAL GRANITE CURB
W	WATER MAIN
WG	WATER GATE

LEGEND

Existing	Proposed	Description
		SPOT ELEVATIONS
		TOP & BOTTOM ELEVATIONS
		SPOT ELEVATIONS WITH LEADER
		HYDRANT
		WATER GATE VALVE
		WELL
		GAS GATE
		ELECTRIC HANDHOLE
		LIGHT POLE
		UTILITY POLE
		GUY POLE
		GUY ANCHOR
		DRAIN MANHOLE
		SEWER MANHOLE
		CATCH BASIN
		DOUBLE CATCH BASIN
		TEST PIT
		BORING
		SIGN SINGLE POST
		GRANITE OR CONCRETE BOUND
		WETLAND FLAG
		EXISTING BUILDING
		PROPOSED BUILDING
		MAJOR CONTOUR
		MINOR CONTOUR
		CHAINLINK FENCE
		CABLE TV LINE
		ELECTRIC, TELEPHONE, CABLE TV DUCTBANK
		UNDERGROUND ELECTRIC
		OVERHEAD ELECTRIC
		NATURAL GAS LINE
		SANITARY SEWER MAIN
		DRAIN PIPE
		TELEPHONE LINE
		WATER MAIN
		FIRE PROTECTION LINE
		RETAINING WALL
		TREELINE
		HAYBALE & SILT FENCE
		LIMIT BORDERING VEGETATED WETLAND RESOURCE(1)
		100' WETLAND BUFFER ZONE

GENERAL NOTES

- SURVEY NOTES:**
- LOCUS IS SHOWN AS PARCEL NUMBER 82-2-2B ON THE TOWN OF NEWBURYPORT ASSESSORS MAPS. LOCUS IS OWNED BY OCEAN REALTY TRUST, C/O JOHN D. HARTNETT, TRS.
 - DEED TO LOCUS IS RECORDED IN THE ESSEX COUNTY REGISTRY OF DEEDS AT BOOK 12598, PAGE 271.
 - THIS SURVEY WAS MADE ON THE GROUND IN OCTOBER OF 2019 BY MCKENZIE ENGINEERING GROUP, INC.
 - ELEVATIONS SHOWN ARE REFERENCED TO THE NORTH AMERICAN VERTICAL DATUM (NAVD) OF 1988.
 - BORDERING VEGETATED WETLANDS DELINEATED BY HUGHES ENVIRONMENTAL CONSULTING IN JANUARY OF 2020 (SERIES A1 - A53).
 - LOCUS IS ZONED INDUSTRIAL - II MINIMUM SETBACK REQUIREMENTS: FRONT YARD 20' SIDE YARD 20' REAR YARD 20'
 - LOCUS IS SITUATED IN ZONE X AS SHOWN ON F.I.R.M. No 25009C0117G, EFFECTIVE 7/16/2014.
 - LOCUS IS NOT LOCATED IN A DEP ZONE 2 AND TOWN OF NEWBURYPORT AQUIFER PROTECTION DISTRICT ZONE.
 - UTILITY INFORMATION FROM ABOVE GROUND OBSERVED EVIDENCE IN CONJUNCTION WITH DIG SAFE MARKINGS AND RECORD PLANS. THE LAND SURVEYOR MAKES NO GUARANTEES THAT THE UNDERGROUND UTILITIES SHOWN HEREON COMPRISE ALL SUCH UTILITIES IN THE AREA, EITHER IN SERVICE OR ABANDONED. THE LAND SURVEYOR FURTHER DOES NOT WARRANT THAT THE UNDERGROUND UTILITIES SHOWN ARE IN THE EXACT LOCATION INDICATED. BEFORE CONSTRUCTION CALL DIG SAFE SYSTEMS, INC. AT 1-888-344-7233.
 - ANY CHANGE IN FIELD CONDITIONS SHALL BE REPORTED TO THE ENGINEER TO INSURE THAT ANY MODIFICATIONS TO THE ORIGINAL DESIGN ARE PROPER AND ADEQUATE TO THE PROJECT NEEDS, AND COMPLY WITH APPLICABLE STANDARDS AND REGULATIONS.
 - PLAN REFERENCES: PB PG 451 5
- UTILITY NOTES:**
- THE CONTRACTOR IS SPECIFICALLY CAUTIONED THAT THE LOCATION AND/OR ELEVATION OF EXISTING UTILITIES AND STRUCTURES AS SHOWN ON THESE PLANS IS BASED ON RECORDS OF VARIOUS UTILITY COMPANIES AND WHERE POSSIBLE, MEASUREMENTS TAKEN IN THE FIELD. THIS INFORMATION IS NOT TO BE RELIED UPON AS BEING EXACT OR COMPLETE. THE LOCATION OF ALL UNDERGROUND UTILITIES AND STRUCTURES SHALL BE VERIFIED IN THE FIELD BY THE CONTRACTOR PRIOR TO THE START OF CONSTRUCTION. THE CONTRACTOR MUST CONTACT THE APPROPRIATE UTILITY COMPANY, ANY GOVERNING PERMITTING AUTHORITY, AND "DIGSAFE" AT LEAST 72 HOURS PRIOR TO ANY EXCAVATION WORK TO REQUEST EXACT FIELD LOCATION OF UTILITIES AND THE ENGINEER SHALL BE NOTIFIED IN WRITING OF ANY UTILITIES INTERFERING WITH THE PROPOSED CONSTRUCTION AND APPROPRIATE REMEDIAL ACTION SHALL BE TAKEN BEFORE PROCEEDING WITH THE WORK. IT SHALL BE THE RESPONSIBILITY OF THE CONTRACTOR TO RELOCATE ALL EXISTING UTILITIES WHICH CONFLICT WITH THE PROPOSED IMPROVEMENTS SHOWN ON THE PLAN.
 - THE CONTRACTOR SHALL BE RESPONSIBLE FOR ESTABLISHING AND MAINTAINING ALL CONTROL POINTS AND BENCHMARKS NECESSARY FOR THE WORK.
 - THE CONTRACTOR SHALL COORDINATE ALL STREET WORK WITH THE NEWBURYPORT DPW.
 - THE CONTRACTOR SHALL EXCAVATE THE TEST PITS PRIOR TO INSTALLING THE DOMESTIC WATER AND FIRE SERVICES TO VERIFY THE ELEVATIONS AND LOCATIONS OF EXISTING UTILITIES. THE CONTRACTOR SHALL PROVIDE THE OWNER AND ENGINEER WITH THE RESULTS PRIOR TO COMMENCING ANY WORK.
 - ALL WATER AND FIRE SERVICES SHALL BE INSTALLED WITH 5' OF COVER EXCEPT AS NOTED OR DETAILED OTHERWISE.
 - THE DOMESTIC WATER SERVICE AND FIRE SERVICE SHALL BE CEMENT LINED DUCTILE IRON PIPE (C.L.D.I.).
 - ALL WATER AND FIRE SERVICE APPURTENANCES, MATERIALS, METHODS OF INSTALLATION SHALL MEET OR EXCEED ALL LOCAL MUNICIPAL REQUIREMENTS.
 - THE FIRE SERVICE AND DOMESTIC WATER SERVICE SHALL BE ADEQUATELY PROTECTED AGAINST BACKFLOW (BACKFLOW PREVENTION) AT THE BUILDING.
 - AFTER PRESSURE TESTING AND CHLORINATION IS COMPLETED, SAMPLES SHALL BE TAKEN FROM THE FIRE SERVICE AND DOMESTIC WATER SERVICE AND SHALL BE TESTED AT 200 PSI FOR A MINIMUM OF 2 HOURS. THE CONTRACTOR IS REQUIRED TO NOTIFY THE NEWBURYPORT DEPARTMENT OF PUBLIC WORKS AT LEAST 24 HOURS PRIOR TO THE TESTING.
 - THE FIRE SERVICE AND DOMESTIC WATER SERVICE SHALL BE TESTED IN ACCORDANCE WITH DEPARTMENT OF ENVIRONMENTAL PROTECTION REGULATIONS. A MINIMUM OF 2 SEPARATE WATER SAMPLES SHALL BE TESTED AT A STATE CERTIFIED LABORATORY.
 - A MINIMUM OF 10 FEET CLEAR HORIZONTALLY SHALL BE MAINTAINED BETWEEN SANITARY SEWER SERVICES AND WATER SERVICES. WHENEVER CONDITIONS PREVENT A LATERAL SEPARATION OF 10 FEET TO A WATER SERVICE THE ELEVATION OF THE CROWN OF THE SEWER SHALL BE AT LEAST 18 INCHES BELOW THE INVERT OF THE WATER SERVICE. ALL OTHER UTILITIES REQUIRE MINIMUM 5' SEPARATION FROM OTHER UTILITIES.
 - ALL GRAVITY SEWER PIPE SHALL BE POLYVINYL CHLORIDE (PVC) SDR-35 UNLESS OTHERWISE NOTED.
 - WHERE SANITARY SEWERS CROSS WATER MAINS, THE SEWER SHALL BE LAID AT SUCH AN ELEVATION THAT THE CROWN OF THE SEWER IS AT LEAST 18 INCHES BELOW THE INVERT OF THE WATER MAIN. IF THE ELEVATION OF THE SEWER CANNOT BE VARIED TO MEET THIS REQUIREMENT, THE WATER MAIN SHALL BE RELOCATED TO PROVIDE THIS SEPARATION OR CONSTRUCTED WITH MECHANICAL-JOINT PIPE FOR A DISTANCE OF 10 FEET ON EACH SIDE OF THE SEWER. ONE FULL LENGTH OF WATER MAIN SHALL BE CENTERED OVER THE SEWER SO THAT BOTH JOINTS WILL BE AS FAR FROM THE SEWER AS POSSIBLE. WHENEVER IT IS IMPOSSIBLE TO OBTAIN VERTICAL SEPARATION AS STIPULATED ABOVE, BOTH THE WATER MAIN AND THE SEWER MAIN SHALL BE ENCASED IN CONCRETE FOR A MINIMUM DISTANCE OF 10 FEET FROM THE CROSSING POINT OF THE OTHER PIPE AS MEASURED NORMALLY FROM ALL POINTS ALONG THE PIPE.
 - THE LOCATIONS OF PROPOSED ELECTRIC, TELEPHONE AND COMMUNICATION (E.T.C.) SERVICES ARE APPROXIMATE. THE PROJECT ELECTRICAL ENGINEER SHALL VERIFY THESE LOCATIONS PRIOR TO THE START OF CONSTRUCTION. COORDINATE ALL E.T.C. WORK WITH THE APPROPRIATE UTILITY COMPANIES.
 - THE PROPOSED GAS SERVICE LOCATION IS APPROXIMATE ONLY. THE CONTRACTOR SHALL COORDINATE THE GAS SERVICE INSTALLATION WITH NATIONAL GRID.
 - ALL CONSTRUCTION WORK SHALL BE PERFORMED IN ACCORDANCE WITH NEWBURYPORT DEPARTMENT OF PUBLIC WORKS SPECIFICATIONS.
 - ALL EXISTING UTILITIES WITHIN THE SITE ARE TO BE REMOVED UNLESS OTHERWISE STATED TO REMAIN.
- CONSTRUCTION PHASE BMP OPERATION AND MAINTENANCE NOTES:**
- STRUCTURAL PRACTICES UTILIZED FOR THE PROJECT WILL INCLUDE SILT SOCK EROSION CONTROL BARRIERS, STABILIZED CONSTRUCTION ENTRANCES, CONCRETE WASH STATIONS, STOCKPILE AREAS, AND INLET PROTECTION.
 - STABILIZATION PRACTICES UTILIZED FOR THE PROJECT WILL INCLUDE TEMPORARY SEEDING, GEOTEXTILES (JUTE MESH), MULCHING, AND PERMANENT SEEDING.
 - OPERATOR PERSONNEL AND/OR ITS CONSULTANTS MUST INSPECT THE CONSTRUCTION SITE AT LEAST ONCE EVERY 7 CALENDAR DAYS OR EVERY 14 CALENDAR DAYS AND WITHIN 24 HOURS OF A STORM EVENT 1/4 INCH OR GREATER. THE INSPECTOR SHOULD REVIEW THE EROSION AND SEDIMENT CONTROLS WITH RESPECT TO THE FOLLOWING:
 - WHETHER OR NOT THE BMP WAS INSTALLED/PERFORMED CORRECTLY.
 - WHETHER OR NOT THERE HAS BEEN DAMAGE TO THE BMP SINCE IT WAS INSTALLED OR PERFORMED.
 - WHAT SHOULD BE DONE TO CORRECT ANY PROBLEMS WITH THE BMP.
 - THE INSPECTOR SHALL COMPLETE THE INSPECTION SCHEDULE AND EVALUATION CHECKLIST FOR FINDINGS AND SHOULD REQUEST THE REQUIRED MAINTENANCE OR REPAIR.
 - ALL SLOPES EXCEEDING 15% RESULTING FROM SITE GRADING SHALL BE BOTH COVERED WITH FOUR INCHES OF TOPSOIL AND PLANTED WITH A VEGETATED COVER SUFFICIENT TO PREVENT EROSION.

REV	DATE	DESCRIPTION
1	4/29/20	REVIEW COMMENTS



**SITE DEVELOPMENT PLANS
PROPOSED MEDICAL BUILDING
20 HENRY GRAF JR. ROAD
NEWBURYPORT, MASSACHUSETTS**

PROFESSIONAL ENGINEER:

APPLICANT:
**SPORTS MEDICINE NORTH
ORTHOPEDIC SURGERY, INC.
C/O CONSERV GROUP, INC.**
 110 STATE ROAD
 SAGAMORE BEACH, MASSACHUSETTS 02562

DRAWN BY: ESS
 DESIGNED BY: ESS
 CHECKED BY: BCM
 APPROVED BY: BCM
 DATE: MARCH 17, 2020
 SCALE:
 PROJECT NO.: 219-180
 DWG. TITLE:
**LEGEND,
ABBREVIATIONS
AND GENERAL
NOTES**

DWG. NO.: **L-1**

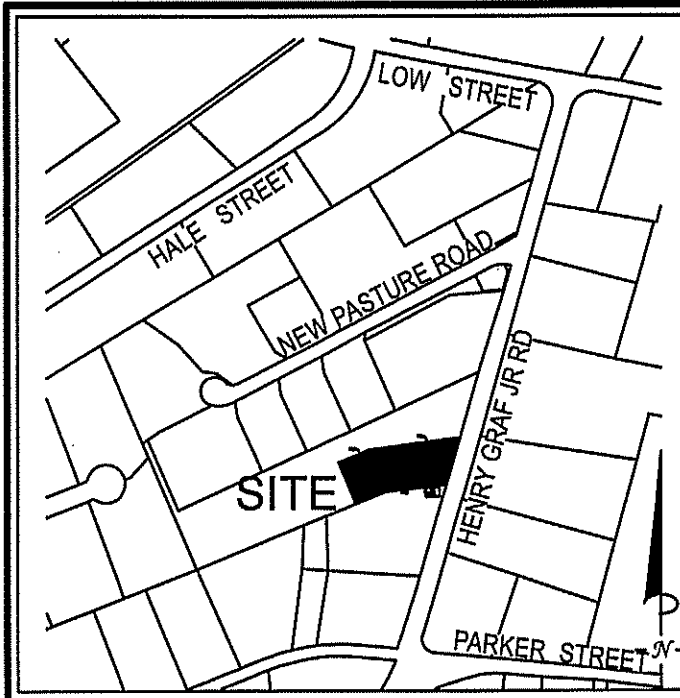

LOCUS MAP
Not to Scale

ABBREVIATIONS

FFE	FIRST FLOOR ELEVATION
BIT CONC.	BITUMINOUS CONCRETE PAVEMENT
CCB	CAPE COD BERM
EP	EDGE OF PAVEMENT
BC	BITUMINOUS CONCRETE CURB
(AM)	AS MEASURED
CALC.	CALCULATED
RET WALL	RETAINING WALL
CONC.	CONCRETE
RCP	REINFORCED CONCRETE PIPE
VCC	VERTICAL GRANITE CURB
VCC	VERTICAL GRANITE CURB

LEGEND

SURVEY SYMBOLS

•	REBAR
□	CONCRETE BOUND WITH DRILL HOLE
○	STONE BOUND
□	STONE BOUND

UTILITY SYMBOLS

⊗	ELECTRIC HAND HOLE
⊗	GUY POLE
-GW	GUY WIRE
⊗	HVAC UNIT
⊗	TRANSFORMER
⊗	WATER GATE
⊗	ELECTRIC MANHOLE
⊗	SEWER MANHOLE
⊗	DRAIN MANHOLE
⊗	TELEPHONE MANHOLE
⊗	DRAINAGE CATCH BASIN
⊗	HYDRANT
⊗	POST INDICATOR VALVE
⊗	UTILITY POLE
⊗	YARD LIGHT
⊗	RIP RAP
⊗	BOLLARD
⊗	SIGN

LINE DESIGNATORS

—	WATER MAIN
—	JERSEY BARRIER
—	GUARD RAIL
—	OVERHEAD WIRES
—	GAS LINE
—	WATER SERVICE
—	UNDERGROUND ELECTRIC
—	STORM DRAIN LINE
—	SANITARY SEWER LINE
—	DRAINAGE SWALE
—	CHAIN LINK FENCE

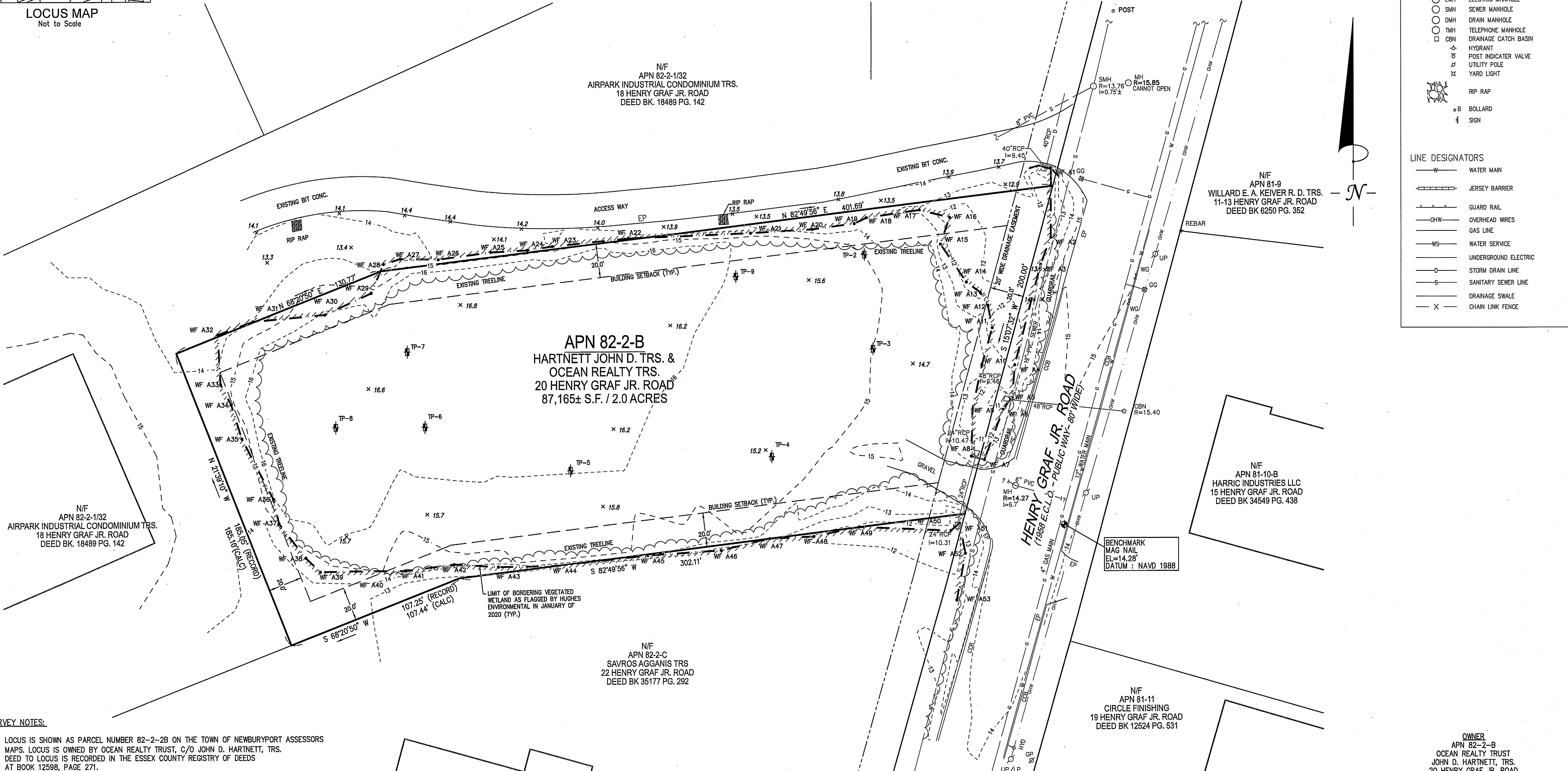

N/F
APN 82-2-1/32
AIRPARK INDUSTRIAL CONDOMINIUM TRS.
18 HENRY GRAF JR. ROAD
DEED BK. 18489 PG. 142

N/F
APN 82-2-1/32
AIRPARK INDUSTRIAL CONDOMINIUM TRS.
18 HENRY GRAF JR. ROAD
DEED BK. 18489 PG. 142

APN 82-2-B
HARTNETT JOHN D. TRS. &
OCEAN REALTY TRS.
20 HENRY GRAF JR. ROAD
87,165± S.F. / 2.0 ACRES

N/F
APN 81-9
WILLARD E. A. KEIVER R. D. TRS.
11-13 HENRY GRAF JR. ROAD
DEED BK 6250 PG. 352

N/F
APN 81-10-B
HARRIC INDUSTRIES LLC
15 HENRY GRAF JR. ROAD
DEED BK 34549 PG. 438

N/F
APN 82-2-C
SAVROS AGGANIS TRS
22 HENRY GRAF JR. ROAD
DEED BK 35177 PG. 292

N/F
APN 81-11
CIRCLE FINISHING
19 HENRY GRAF JR. ROAD
DEED BK 12524 PG. 531

OWNER
APN 82-2-B
OCEAN REALTY TRUST
JOHN D. HARTNETT, TRS.
20 HENRY GRAF JR. ROAD
DEED BK. 12598 PG. 271

- SURVEY NOTES:**
- LOCUS IS SHOWN AS PARCEL NUMBER 82-2-2B ON THE TOWN OF NEWBURYPORT ASSESSORS MAPS. LOCUS IS OWNED BY OCEAN REALTY TRUST, C/O JOHN D. HARTNETT, TRS.
 - DEED TO LOCUS IS RECORDED IN THE ESSEX COUNTY REGISTRY OF DEEDS AT BOOK 12598, PAGE 271.
 - THIS SURVEY WAS MADE ON THE GROUND IN OCTOBER OF 2019 BY MCKENZIE ENGINEERING GROUP, INC.
 - ELEVATIONS SHOWN ARE REFERENCED TO THE NORTH AMERICAN VERTICAL DATUM (NAVD) OF 1988.
 - BORDERING VEGETATED WETLANDS DELINEATED BY HUGHES ENVIRONMENTAL CONSULTING IN JANUARY OF 2020 (SERIES A1 - A53).
 - LOCUS IS ZONED INDUSTRIAL - I1 MINIMUM SETBACK REQUIREMENTS:
FRONT YARD 20'
SIDE YARD 20'
REAR YARD 20'
 - LOCUS IS SITUATED IN ZONE X AS SHOWN ON F.I.R.M. No 25009C0117G, EFFECTIVE 7/16/2014.
 - LOCUS IS NOT LOCATED IN A DEP ZONE 2 AND TOWN OF NEWBURYPORT AQUIFER PROTECTION DISTRICT ZONE.
 - UTILITY INFORMATION FROM ABOVE GROUND OBSERVED EVIDENCE IN CONJUNCTION WITH DIG SAFE MARKINGS AND RECORD PLANS. THE LAND SURVEYOR MAKES NO GUARANTEES THAT THE UNDERGROUND UTILITIES SHOWN HEREON COMPRISE ALL SUCH UTILITIES IN THE AREA, EITHER IN SERVICE OR ABANDONED. THE LAND SURVEYOR FURTHER DOES NOT WARRANT THAT THE UNDERGROUND UTILITIES SHOWN ARE IN THE EXACT LOCATION INDICATED. BEFORE CONSTRUCTION CALL DIG SAFE SYSTEMS, INC. AT 1-888-344-7233.
 - PLAN REFERENCES:
PB 451 PG 5



© MCKENZIE ENGINEERING GROUP, INC.

REV	DATE	DESCRIPTION	BY	APP



20 HENRY GRAF JR. ROAD
NEWBURYPORT, MASSACHUSETTS

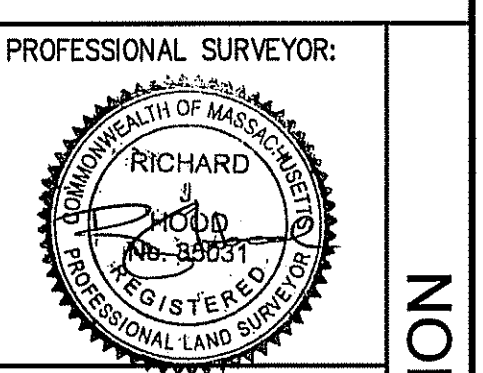

APPLICANT:
SPORTS MEDICINE NORTH ORTHOPEDIC SURGERY, INC.
110 STATE ROAD
SAGAMORE BEACH, MASSACHUSETTS

DRAWN BY: ESS
CHECKED BY: RTLS
APPROVED BY: RJH
DATE: MARCH 17, 2020
SCALE: 1"=30'
PROJECT NO.: 219-180
DWG. TITLE:

EXISTING CONDITIONS PLAN

DWG. NO: **EX-1**

NOT FOR CONSTRUCTION

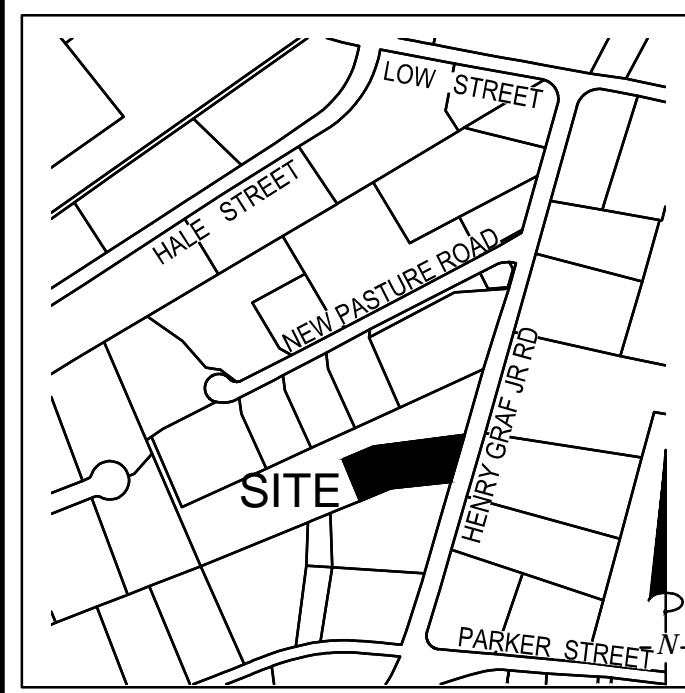

LOCUS MAP
Not to Scale

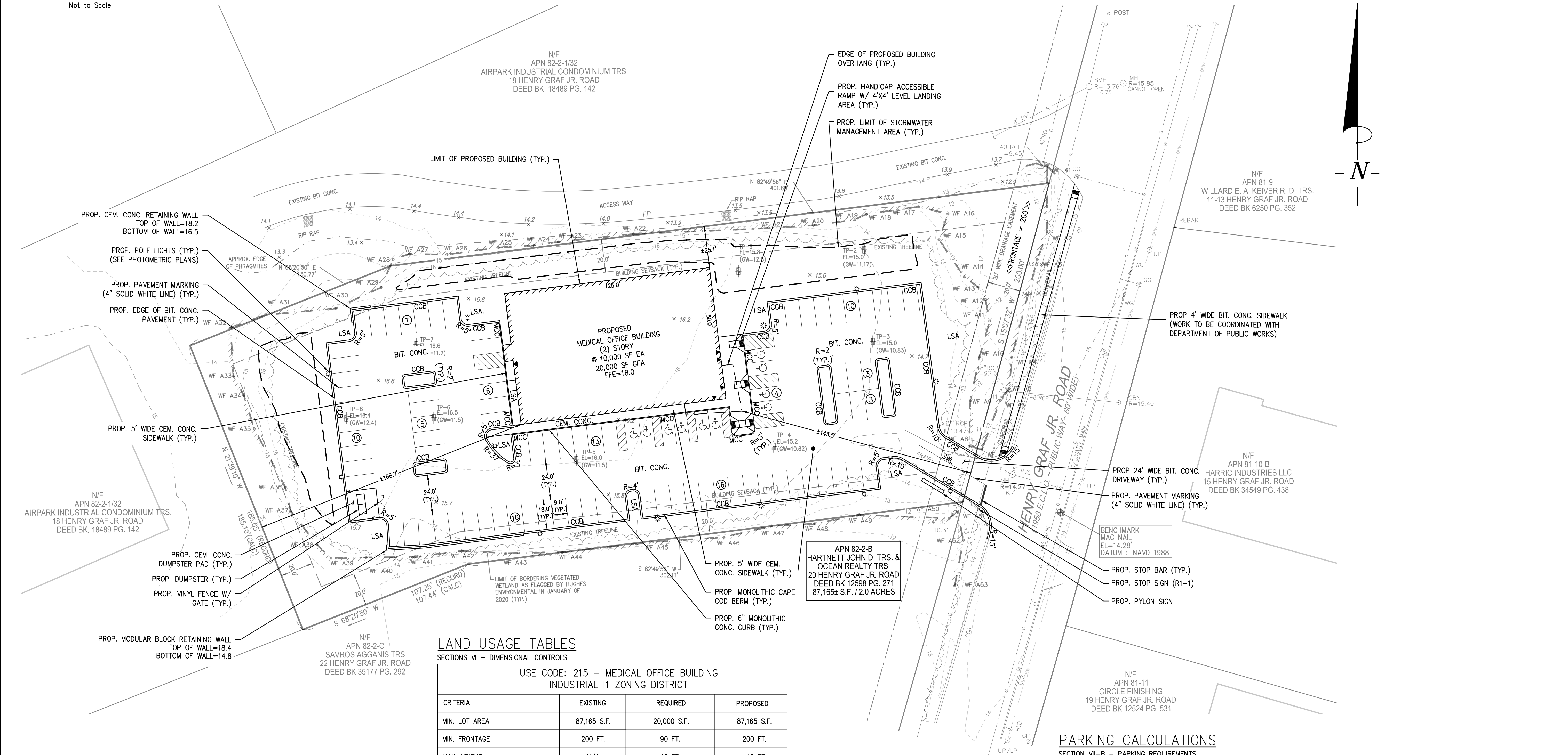

LAND USAGE TABLES

SECTIONS VI - DIMENSIONAL CONTROLS

USE CODE: 215 - MEDICAL OFFICE BUILDING INDUSTRIAL I1 ZONING DISTRICT			
CRITERIA	EXISTING	REQUIRED	PROPOSED
MIN. LOT AREA	87,165 S.F.	20,000 S.F.	87,165 S.F.
MIN. FRONTAGE	200 FT.	90 FT.	200 FT.
MAX. HEIGHT	N/A	40 FT.	<40 FT.
MAX. % LOT COVERAGE	N/A	50%	12.0%
OPEN SPACE	N/A	N/A	N/A
MIN. FRONT YARD	N/A	20 FT.	±143.5 FT.
MIN. SIDE YARD	N/A	20 FT.	±25.1 FT.
MIN. REAR YARD	N/A	20 FT.	±168.7 FT.

NOTES:
 1. SECTION XV-Hd.1. - A LANDSCAPED BUFFER STRIP AT LEAST 20' IN WIDTH SHALL BE ESTABLISHED ADJACENT TO ANY PUBLIC ROAD.
 2. SECTION XV-Hd.4. - AT LEAST 5% OF THE INTERIOR OF THE PARKING AREA SHALL BE MAINTAINED WITH LANDSCAPING, INCLUDING TREES, IN LANDSCAPE ISLANDS OR PLOTS OF AT LEAST NINE FEET IN WIDTH WITH NO MORE THAN 20 PARKING SPACES BETWEEN EACH ISLAND OR PLOT. (6.3% PROVIDED BY THIS SUBMISSION)

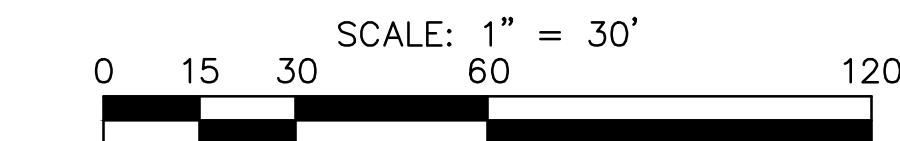

PARKING CALCULATIONS

SECTION VII-B - PARKING REQUIREMENTS

CRITERIA	REQUIRED (NEWBURYPORT ZONING ORDINANCE)	REQUIRED	PROPOSED
USE CODE 215: MEDICAL OFFICE BUILDING	1 SPACE/2 EMPLOYEES = 40 EMPLOYEES/2 EMPLOYEES PER SPACE = 20 SPACES 1 SPACE/300 SF GFA = 20,000 SF. GFA/300 SF GFA PER SPACE = 67 SPACES 20 + 67 = 87 SPACES	87 SPACES	93 SPACES

PARKING NOTES:
 1. SPECIALIZED MEDICAL FACILITIES: OUTPATIENT UNITS AND FACILITIES: 10% OF THE TOTAL NUMBER OF PARKING SPACES PROVIDED TO SERVE EACH SUCH OUTPATIENT UNIT OR FACILITY SHALL BE ACCESSIBLE (521 CMR: ARCHITECTURAL ACCESS BOARD).
 2. 93 TOTAL SPACES INCLUDES 10 AAB ACCESSIBLE 9' X 18' WITH 4 - 8' X 18' ACCESS AREA (VAN ACCESSIBLE SPACE) (521 CMR: ARCHITECTURAL ACCESS BOARD) ACCESSIBLE SPACES REQUIRED = 10 (10% OF 93 TOTAL SPACES)

REV	DATE	DESCRIPTION	BY	APP
1	4/29/20	REVIEW COMMENTS	ESS	BCM



**SITE DEVELOPMENT PLANS
PROPOSED MEDICAL BUILDING
20 HENRY GRAF JR. ROAD
NEWBURYPORT, MASSACHUSETTS**



APPLICANT:
 SPORTS MEDICINE NORTH
 ORTHOPEDIC SURGERY, INC.
 C/O CONSERV GROUP, INC.
 110 STATE ROAD
 SAGAMORE BEACH, MASSACHUSETTS 02562

DRAWN BY: ESS
 DESIGNED BY: ESS
 CHECKED BY: BCM
 APPROVED BY: BCM
 DATE: MARCH 17, 2020
 SCALE: 1" = 30'
 PROJECT NO.: 219-180
 DWG. TITLE:

**SITE LAYOUT
PLAN**

DWG. NO.: **C-1**

NOT FOR CONSTRUCTION

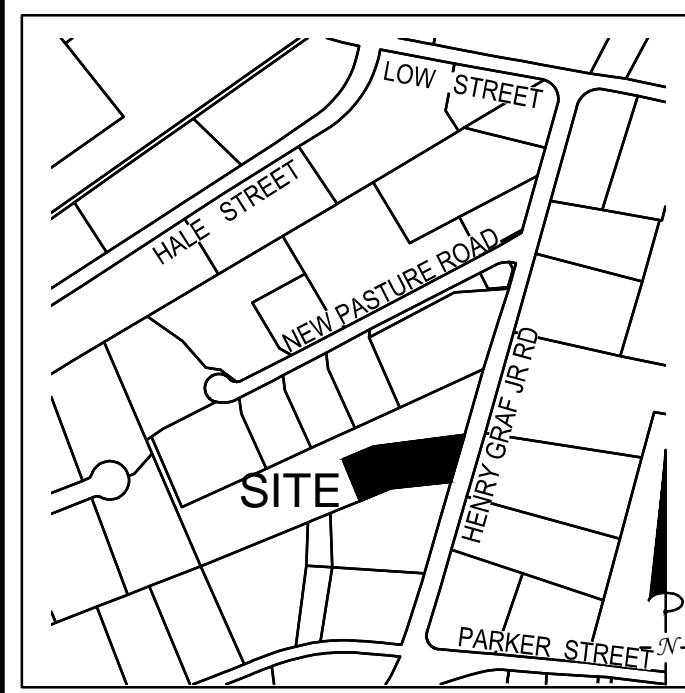

LOCUS MAP
Not to Scale

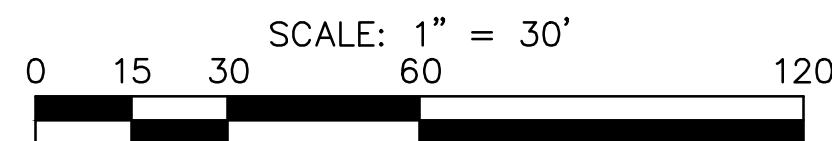
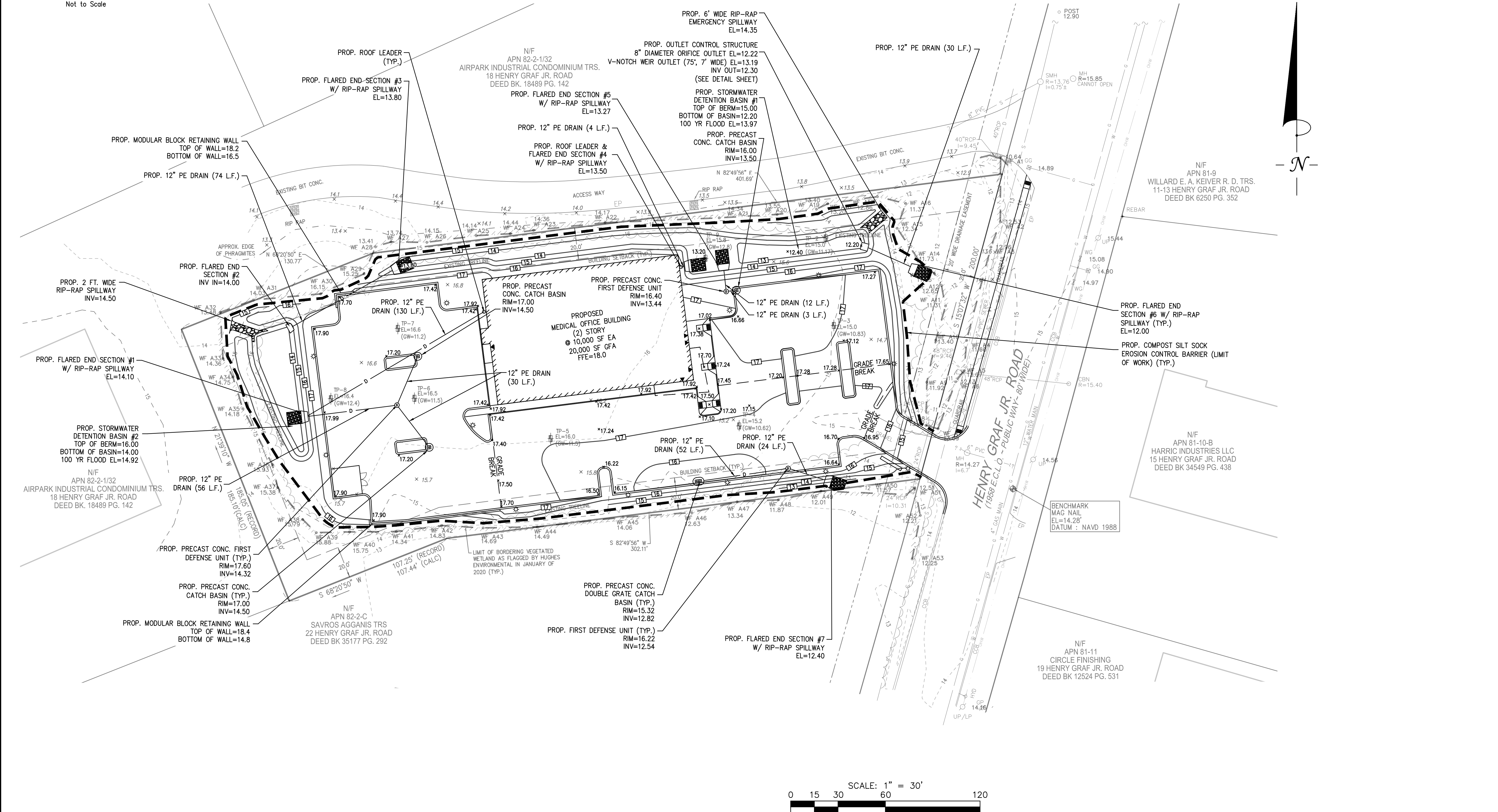

REV	DATE	DESCRIPTION	BY	APP
1	4/29/20	REVIEW COMMENTS	ESS	BCM



**SITE DEVELOPMENT PLANS
PROPOSED MEDICAL BUILDING
20 HENRY GRAF JR. ROAD
NEWBURYPORT, MASSACHUSETTS**

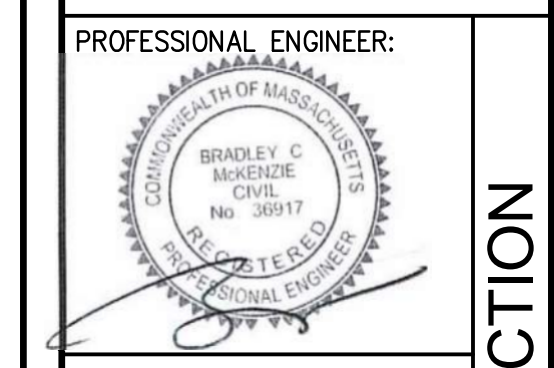

APPLICANT:
**SPORTS MEDICINE NORTH
ORTHOPEDIC SURGERY, INC.
C/O CONSERV GROUP, INC.
110 STATE ROAD
SAGAMORE BEACH, MASSACHUSETTS 02562**

PROFESSIONAL ENGINEER:
**BRADLEY C. MCKENZIE
No. 98917
State of Massachusetts**

NOT FOR CONSTRUCTION

DRAWN BY: ESS
DESIGNED BY: ESS
CHECKED BY: BCM
APPROVED BY: BCM
DATE: MARCH 17, 2020
SCALE: 1" = 30'
PROJECT NO.: 219-180
DWG. TITLE:
**GRADING AND
DRAINAGE
PLAN**
DWG. NO.:
C-2

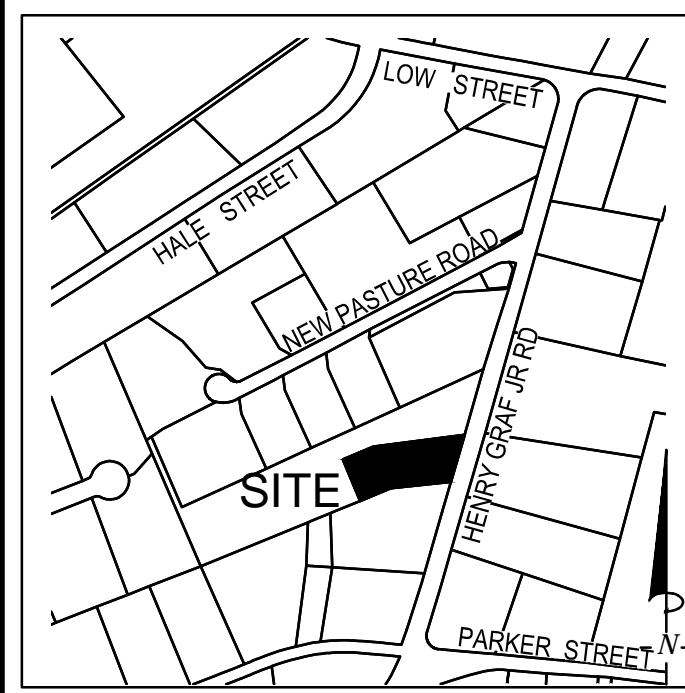

LOCUS MAP
Not to Scale

N/F
APN 82-2-1/32
AIRPARK INDUSTRIAL CONDOMINIUM TRS.
18 HENRY GRAF JR. ROAD
DEED BK. 18489 PG. 142

N/F
APN 81-9
WILLARD E. A. KEIVER R. D. TRS.
11-13 HENRY GRAF JR. ROAD
DEED BK 6250 PG. 352

N/F
APN 81-10-B
HARRIC INDUSTRIES LLC
15 HENRY GRAF JR. ROAD
DEED BK 34549 PG. 438

N/F
APN 82-2-C
SAVROS AGGANIS TRS
22 HENRY GRAF JR. ROAD
DEED BK 35177 PG. 292

PROP. THRUST BLOCKS AT BEND
IN WATER SERVICES (TYP.)

PROP. UNDERGROUND ELECTRIC,
TELEPHONE & CABLE UTILITIES
(CONNECTION TO BE DETERMINED
BY NATIONAL GRID)

PROP. CORP. STOP AND CURB
STOP OR DI TAPPING SLEEVE
AND VALVE (TO BE DETERMINED
BY MECH. ENGINEER)

BENCHMARK
MAG NAIL
EL=14.28'
DATUM : NAVD 1988

PROP. DI TAPPING SLEEVE AND
VALVE W/ THRUST BLOCKS AT
SERVICE CONNECTIONS (TYP.)
PROP. CHIMNEY SEWER
CONNECTION
INV=1.56

N/F
APN 81-11
CIRCLE FINISHING
19 HENRY GRAF JR. ROAD

PROP. 6" PVC SEWER
SERVICE (SDR-35)
PROP. SEWER SERVICE
CLEANOUT
PROP. DI DOMESTIC WATER
SERVICE (SIZE TO BE DETERMINED
BY MECH. ENGINEER)
PROP. CLDI FIRE SERVICE (SIZE TO
BE DETERMINED BY FIRE PROTECTION
ENGINEER)
PROP. GAS SERVICE
(SIZE TO BE DETERMINED
BY NATIONAL GRID)

LIMIT OF BORDERING VEGETATED
WETLAND AS FLAGGED BY HUGHES
ENVIRONMENTAL IN JANUARY OF
2020 (TYP.)

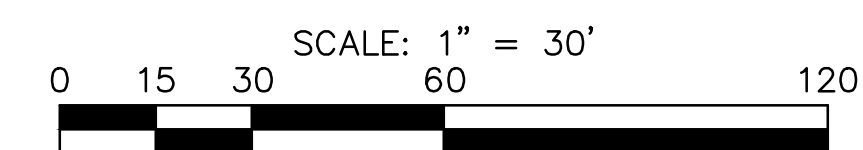
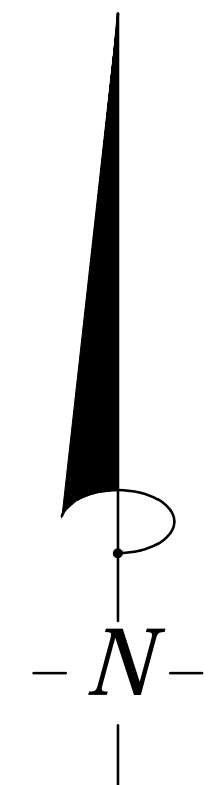
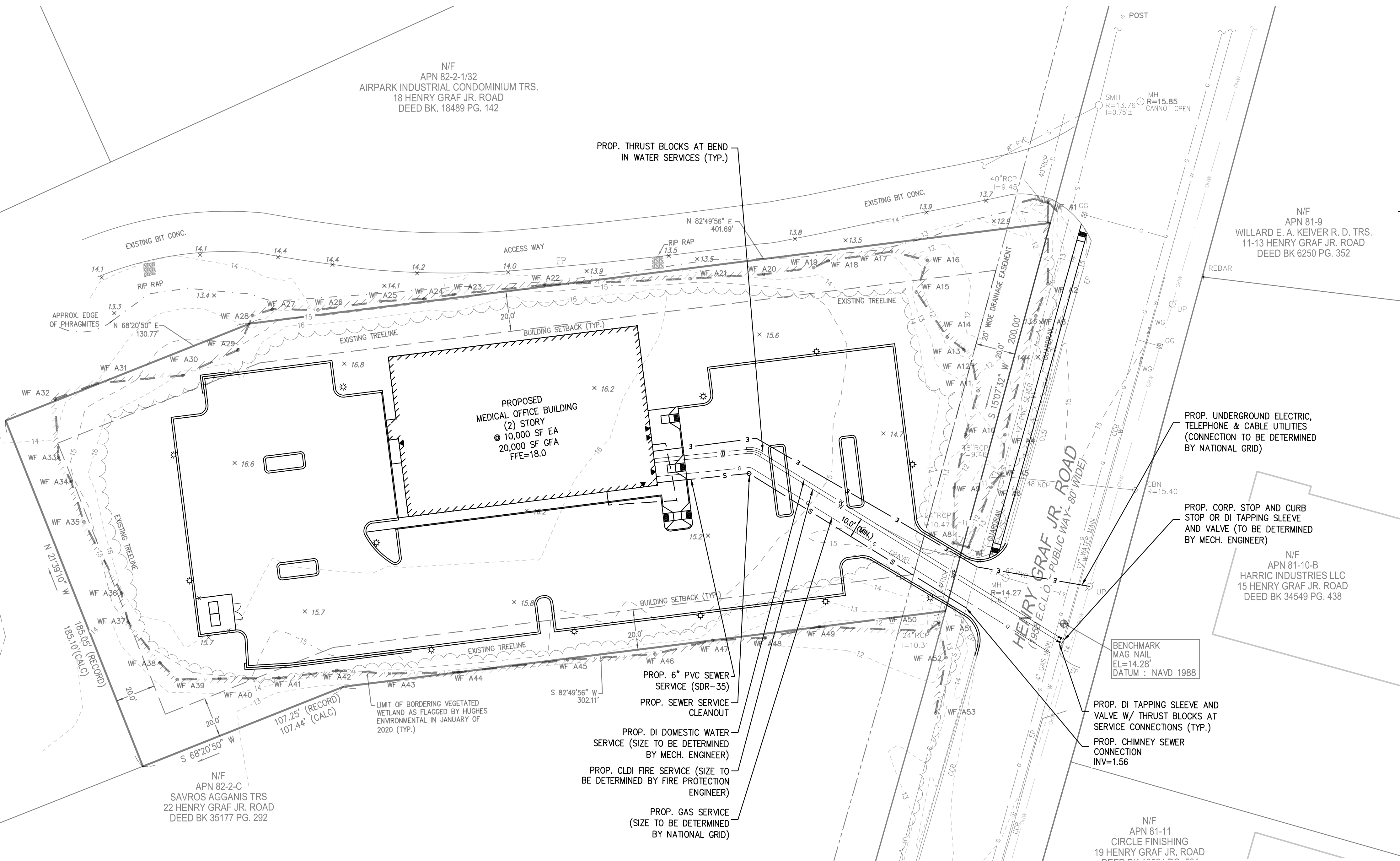

REV	DATE	DESCRIPTION	BY	APP
1	4/29/20	REVIEW COMMENTS	ESS	BCM

MG
MCKENZIE
ENGINEERING GROUP
Mississippi Office Park
150 Longwater Drive, Suite 101
Norwell, MA 02061
P: 781.792.3900
F: 781.792.0333
www.mckeng.com

**SITE DEVELOPMENT PLANS
PROPOSED MEDICAL BUILDING
20 HENRY GRAF JR. ROAD
NEWBURYPORT, MASSACHUSETTS**

PROFESSIONAL ENGINEER:

BRADLEY C. MCKENZIE
No. 38917
Civil Engineer
State of Massachusetts

APPLICANT:
SPORTS MEDICINE NORTH
ORTHOPEDIC SURGERY, INC.
C/O CONSERV GROUP, INC.
110 STATE ROAD
SAGAMORE BEACH, MASSACHUSETTS 02562

DRAWN BY: ESS
DESIGNED BY: ESS
CHECKED BY: BCM
APPROVED BY: BCM
DATE: MARCH 17, 2020
SCALE: 1" = 30'
PROJECT NO.: 219-180
DWG. TITLE:

UTILITY PLAN

DWG. NO.:
C-3

NOT FOR CONSTRUCTION

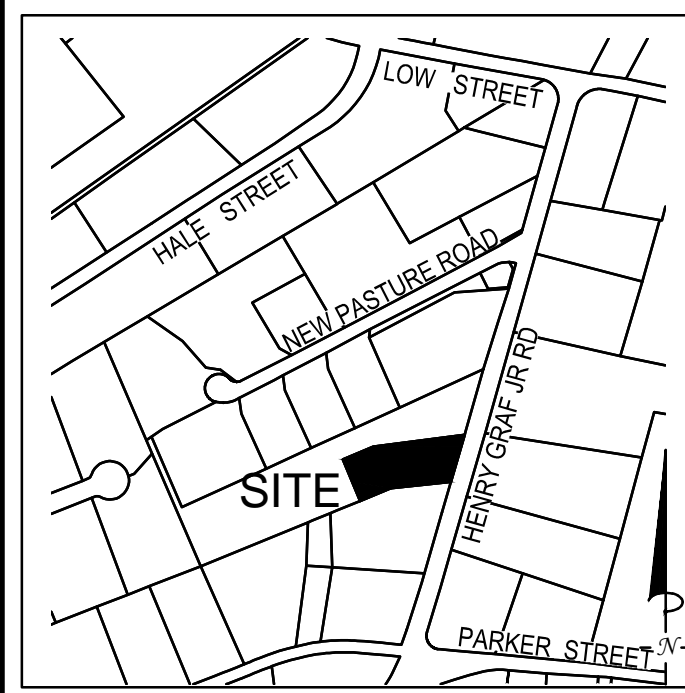

LOCUS MAP
Not to Scale

CONSTRUCTION SEQUENCE

TO PREVENT EXCESSIVE EROSION AND SILTING, THE FOLLOWING CONSTRUCTION SEQUENCE COUPLED WITH OTHER WIDELY ACCEPTED PRINCIPALS FOR REDUCING EROSION AND SEDIMENTATION SHALL BE IMPLEMENTED IN THE DEVELOPMENT OF THE SITE.

1. THE CONTRACTOR SHALL COORDINATE A PRE-CONSTRUCTION MEETING PRIOR TO ANY CONSTRUCTION ACTIVITY.
2. STABILIZATION PRACTICES FOR EROSION AND SEDIMENT CONTROL SHALL BE INSTALLED PRIOR TO COMMENCING CONSTRUCTION ACTIVITIES. REFER TO "EROSION AND SEDIMENTATION CONTROL" SECTION OF THIS PLAN & PLACE SILTATION FENCE ON THE SITE PLANS.
3. CLEAR AND GRUB UP AS REQUIRED FOR THE CONSTRUCTION OF THE DRIVEWAY AND RELATED INFRASTRUCTURE.
4. CONSTRUCT STABILIZED CONSTRUCTION ENTRANCE.
5. EXCAVATE TOPSOIL AND SUBSOIL FROM CUT AND FILL AREAS AND STOCKPILE ON SITE IN LOCATIONS SHOWN ON THE PLAN. CONSIDERATION SHOULD BE GIVEN TO LOCATING STOCKPILES ON THE UPHILL SIDE OF DISTURBED AREAS, WHERE POSSIBLE, TO ACT AS TEMPORARY DIVERSIONS.
6. CONSTRUCT CUT AND FILL AREAS, INSTALLING HAYBALE CHECK DAMS AT TOES OF ALL 3:1 OR GREATER SLOPES, AND AT ENDS OF ALL CUT AREAS. ALL FILL WILL BE INSTALLED USING 12" MAXIMUM COMPACTION LIFTS. PLACE ALL SLOPE PROTECTION WHERE INDICATED ON THE PLAN. THE STORMWATER DETENTION BASIN SHALL BE CONSTRUCTED IMMEDIATELY AFTER THE DRIVEWAY ROUGH GRADING IS COMPLETED AND THE AREA HAS BEEN CLEARED OF VEGETATION.
7. INSTALL CLOSED DRAINAGE SYSTEM AND OTHER UTILITIES. ALL CATCH BASINS SHALL BE COVERED WITH SILTSACK OR EQUIVALENT INLET PROTECTION.
8. GRADE DRIVEWAY TO SUBGRADE ELEVATION AND CONSTRUCT SIDE SLOPES. APPLY TEMPORARY STABILIZATION MEASURES WHERE WARRANTED. REFER TO "EROSION AND SEDIMENTATION CONTROL" SECTION OF THIS PLAN.
9. PLACE GRAVEL SUBBASE.
10. PLACE THE BITUMINOUS CONCRETE BINDER COURSE ON DRIVEWAY AND PARKING LOT.
11. GRADE SLOPES AND STABILIZE CUT AREAS AT TOE OF SLOPES. BLEND ALL SLOPES INTO EXISTING TOPOGRAPHY AND LOAM AND SEED ALL DISTURBED AREAS. SLOPES GREATER THAN 3:1 SHALL BE STABILIZED WITH JUTE MESH. PLACE THE FINAL WEARING COURSE OF PAVEMENT.
12. COMPLETE FINE GRADING OF SHOULDERS AND PLACE PAVEMENT IN MISCELLANEOUS AREAS.
13. REMOVE TEMPORARY EROSION CONTROL DEVICES ONCE ADEQUATE GROWTH IS ESTABLISHED. ADEQUATE GROWTH IS DEFINED AS VEGETATION COVERING 75% OR MORE OF THE GROUND SURFACE.

GENERAL CONSTRUCTION NOTES

1. DETENTION BASINS WILL BE DELINEATED BY STAKES WITH CAUTION TAPE AND/OR CONSTRUCTION FENCING PRIOR TO CONSTRUCTION TO PROTECT FROM SOIL COMPACTION. NO HEAVY EQUIPMENT WILL BE ALLOWED IN THIS AREA.
2. TOPSOIL AND EXCAVATED STOCKPILES WILL BE STORED IN SEPARATE STOCKPILE AREAS. THE CONTRACTOR MAY ADJUST THE SIZE AND LOCATION OF STOCKPILE AREAS AS NEEDED.
3. STUMPS, LOGS AND DEBRIS HINDERING CONSTRUCTION ACTIVITY SHALL BE REMOVED PRIOR TO CONSTRUCTION AND DISPOSED OF IN ACCORDANCE WITH LOCAL AND STATE REGULATIONS.
4. FAIRCLOTH SKIMMER WITH DISCHARGE SYSTEM SHALL BE INSTALLED IN ALL TEMPORARY SEDIMENTATION BASINS. SEE DETAIL SHEET FOR MORE INFORMATION.
5. UNSUITABLE MATERIAL INCLUDING THE EXISTING STOCKPILE WILL BE REMOVED AND/OR RELOCATED FROM SITE PRIOR TO CONSTRUCTION OF INDIVIDUAL LOTS.

LIMIT OF PROPOSED DETENTION BASIN TO BE USED AS TEMPORARY SEDIMENT CONTROL AREA (TYP.)

N/F APN 82-2-1/32 AIRPARK INDUSTRIAL CONDOMINIUM TRS. 18 HENRY GRAF JR. ROAD DEED BK. 18489 PG. 142

PROP. TEMPORARY SEDIMENTATION BASIN #1
CONTRIBUTORY AREA = 24,822 S.F.
REQUIRED VOLUME = (24,822 X 3,600 CUBIC FEET/ACRE) / 43,560 S.F./ACRE = 2,051 CUBIC FEET OF STORAGE (MIN)
TOP OF BASIN = 16.5
BOTTOM OF BASIN = 15.5

N/F APN 82-2-C SAVROS AGGANIS TRS 22 HENRY GRAF JR. ROAD DEED BK 35177 PG. 292

N/F APN 82-2-1/32 AIRPARK INDUSTRIAL CONDOMINIUM TRS. 18 HENRY GRAF JR. ROAD DEED BK. 18489 PG. 142

N/F APN 81-9 WILLARD E. A. KEIVER R. D. TRS. 11-13 HENRY GRAF JR. ROAD DEED BK 6250 PG. 352

N/F APN 81-10-B HARRIC INDUSTRIES LLC 15 HENRY GRAF JR. ROAD DEED BK 34549 PG. 438

N/F APN 81-11 CIRCLE FINISHING 19 HENRY GRAF JR. ROAD

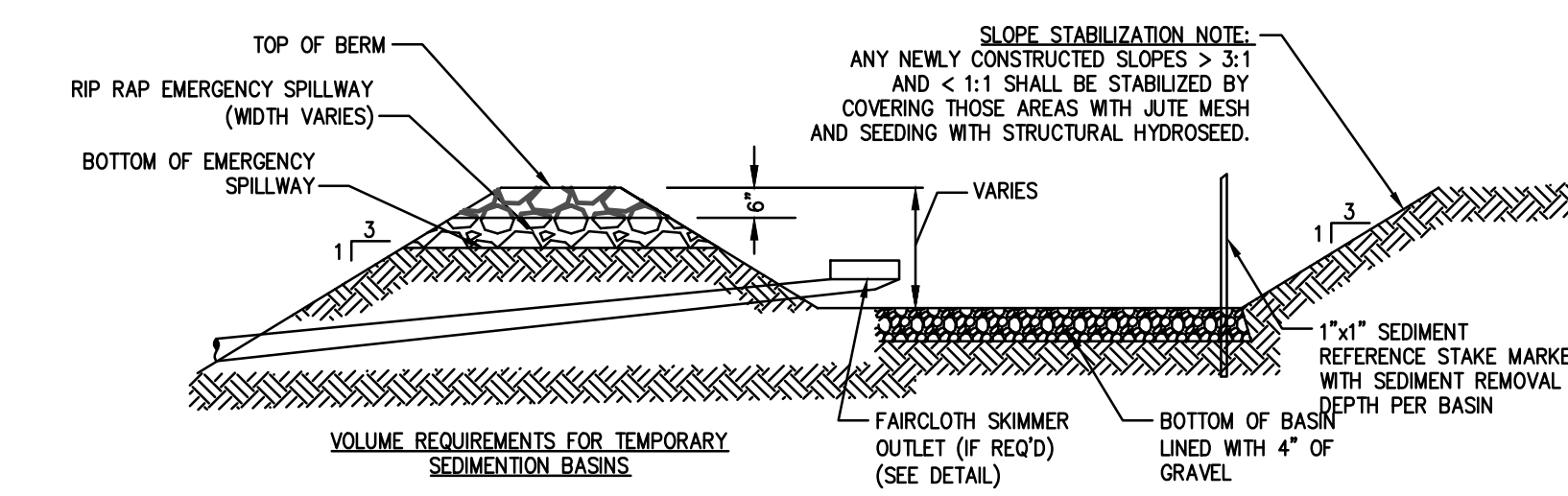

VOLUME REQUIREMENTS FOR TEMPORARY SEDIMENTATION BASINS
TEMPORARY SEDIMENTATION BASINS SHALL HAVE A MINIMUM VOLUME BASED ON 3,600 Cu. Ft. OF STORAGE FOR EACH ACRE DRAINED TO BASIN.

CONSTRUCTION NOTE:
TEMPORARY SEDIMENTATION BASINS SHALL BE INSTALLED AS CLOSE AS POSSIBLE TO LOCATIONS SHOWN ON THE PLAN, BUT SITE CONDITIONS SUCH AS SOILS, POOL AREA, AND SPILLWAY CONDITIONS SHALL BE CONSIDERED. CONTRACTOR SHALL HAVE THE FLEXIBILITY TO ADJUST LOCATIONS AS LONG AS REQUIRED VOLUME IS PROVIDED.

TEMPORARY SEDIMENTATION BASIN
NOT TO SCALE

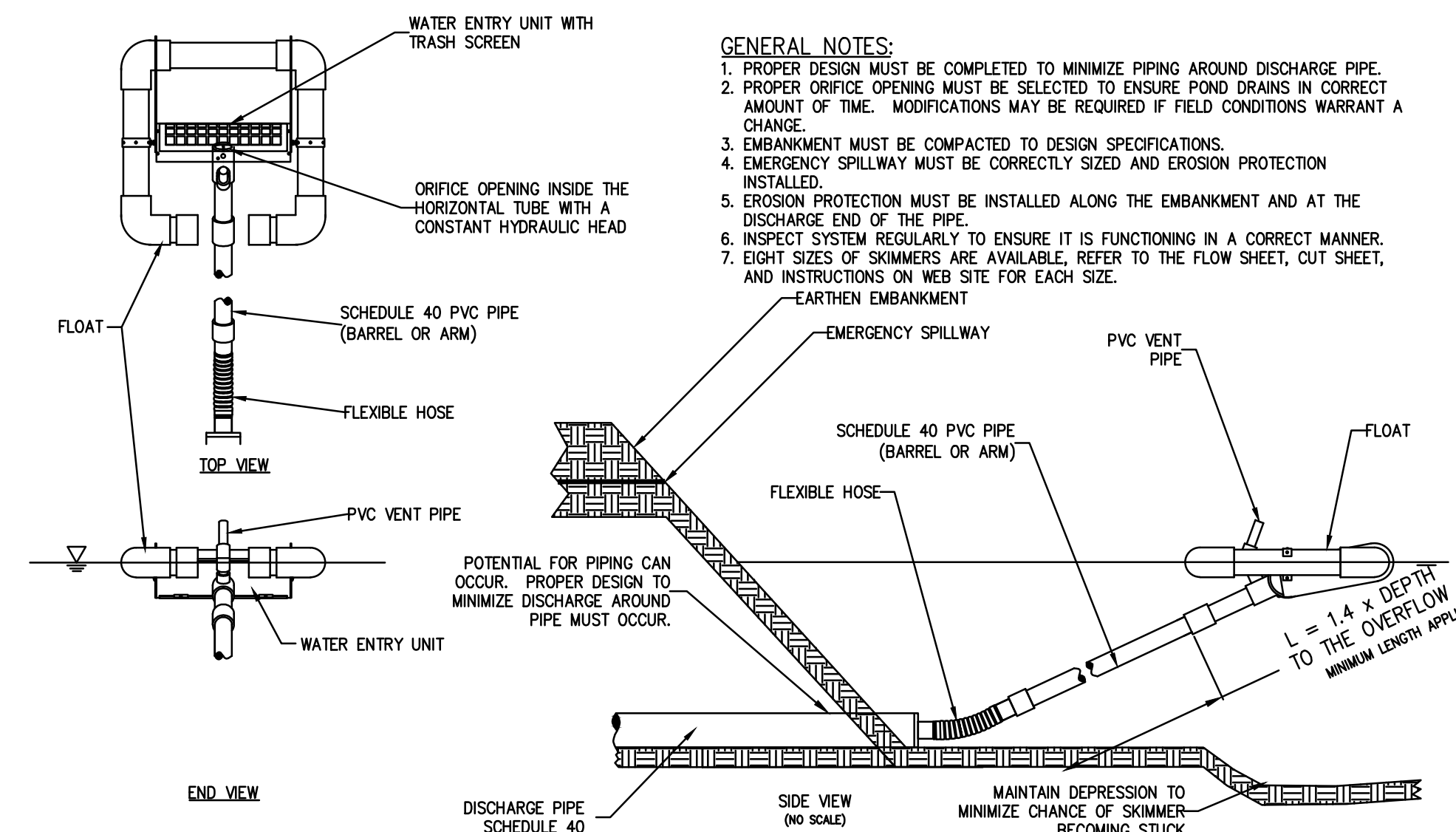
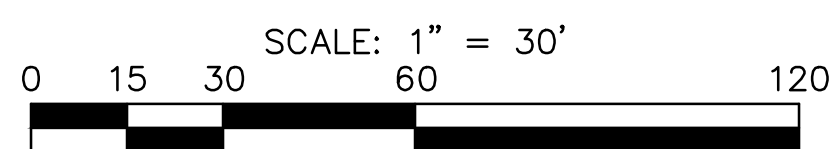

GENERAL NOTES:
1. PROPER DESIGN MUST BE COMPLETED TO MINIMIZE PIPING AROUND DISCHARGE PIPE.
2. PROPER ORIFICE OPENING MUST BE SELECTED TO ENSURE POND DRAINS IN CORRECT AMOUNT OF TIME. MODIFICATIONS MAY BE REQUIRED IF FIELD CONDITIONS WARRANT A CHANGE.
3. EMBANKMENT MUST BE COMPACTED TO DESIGN SPECIFICATIONS.
4. EMERGENCY SPILLWAY MUST BE CORRECTLY SIZED AND EROSION PROTECTION INSTALLED.
5. EROSION PROTECTION MUST BE INSTALLED ALONG THE EMBANKMENT AND AT THE DISCHARGE END OF THE PIPE.
6. INSPECT SYSTEM REGULARLY TO ENSURE IT IS FUNCTIONING IN A CORRECT MANNER.
7. EIGHT SIZES OF SKIMMERS ARE AVAILABLE, REFER TO THE FLOW SHEET, CUT SHEET, AND INSTRUCTIONS ON WEB SITE FOR EACH SIZE.

FAIRCLOTH SKIMMER DISCHARGE SYSTEM W/ EMBANKMENT
NOT TO SCALE

REV	DATE	DESCRIPTION	BY	APP
1	4/29/20	REVIEW COMMENTS	ESS	BCM

MG
MCKENZIE
ENGINEERING GROUP
Mississippi Office Park
150 Longwater Drive, Suite 101
Norwell, MA 02061
P: 781.792.3900
F: 781.792.0333
www.mckeng.com

**SITE DEVELOPMENT PLANS
PROPOSED MEDICAL BUILDING
20 HENRY GRAF JR. ROAD
NEWBURYPORT, MASSACHUSETTS**

PROFESSIONAL ENGINEER:



APPLICANT:
SPORTS MEDICINE NORTH
ORTHOPEDIC SURGERY, INC.
C/O CONSERV GROUP, INC.
110 STATE ROAD
SAGAMORE BEACH, MASSACHUSETTS 02562

DRAWN BY: ESS
DESIGNED BY: ESS
CHECKED BY: BCM
APPROVED BY: BCM
DATE: MARCH 17, 2020
SCALE: 1" = 30'
PROJECT NO.: 219-180
DWG. TITLE:

**EROSION AND
SEDIMENT
CONTROL PLAN**

DWG. NO.: **ESC-1**

NOT FOR CONSTRUCTION

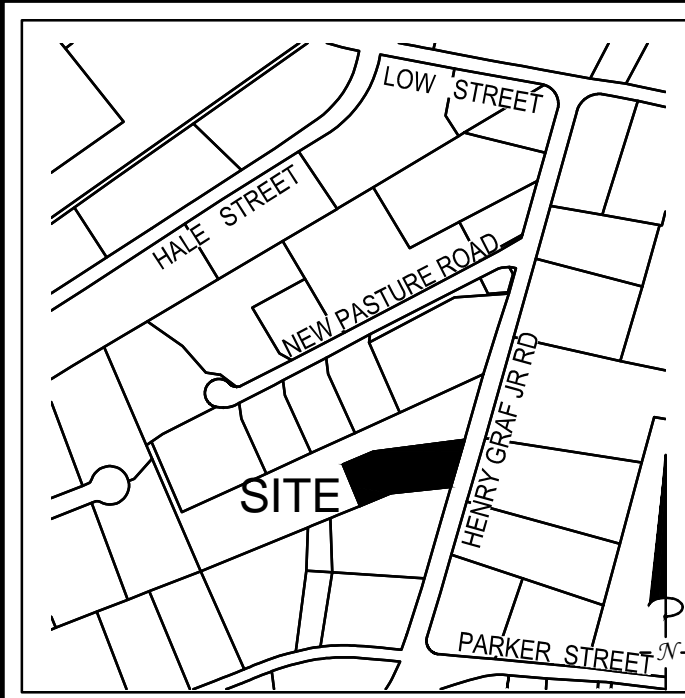

LOCUS MAP
Not to Scale

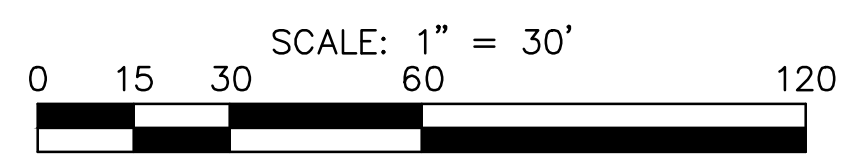

PLANT LIST

SYMBOL

TREES

SYMBOL	QTY	BOTANICAL NAME	COMMON NAME	SIZE	REMARKS
AR	18	ACER RUBRUM	RED MAPLE	3 - 3.5" CAL.	
AR-1	6	ACER RUBRUM	RED MAPLE	1 - 1.5" CAL.	IN INVASIVE CONTROL AREA
BN	1	BETULA NIGRA 'DURA HEAT'	DURA HEAT RIVER BIRCH	10 - 12- HEIGHT	MULTI-STEM 3-5 STEM

SHRUBS/SMALL TREES

SD	8	SALIX DISCOLOR	PUSSY WILLOW	1 - 1.5" CAL.	
SD-1	30	SALIX DISCOLOR	PUSSY WILLOW	TUBLINGS	FILL IN GAPS, AND IN INVASIVE CONTROL AREAS
AC	2	AMELANCHIER CANADENSIS	SERVICEBERRY	2 - 2.5" CAL.	
CS	6	CORNUS SERICIA	REDOSIER DOGWOOD	5 GAL	4' TRIA. SPACING
CS-1	10	CORNUS SERICIA	REDOSIER DOGWOOD	3-4'	6' ON CENTER, NEWP SOURCE AS SHOWN AND IN INVASIVE CONTROL AREA
CS-2	60	CORNUS SERICIA	REDOSIER DOGWOOD	TUBLINGS	FILL IN GAPS, NEWP SOURCE

SEED MIX

LOW MOW FESCUE	AREAS NEAR BUILDING FOR MANICURED LOOK AND AREAS FOR VEHICLE OVERHANG
NEW ENGLAND SHOWY WILDFLOWER MIX	SLOPES AND AREAS OUTSIDE BASINS
CONSERVATION MIX	BASINS/SWALES

PROPOSED PLANTING TABLE & SURFACE TREATMENTS

	CONSERVATION MIX
	LOW MOW FESCUE
	NEW ENGLAND SHOWY WILDFLOWER MIX
	PROPOSED BUILDING
	BITUMINOUS CONCRETE
	CEMENT CONCRETE

REV	DATE	DESCRIPTION	BY	APP
1	4/29/20	REVIEW COMMENTS	ESS	BCM



**SITE DEVELOPMENT PLANS
PROPOSED MEDICAL BUILDING
20 HENRY GRAF JR. ROAD
NEWBURYPORT, MASSACHUSETTS**

PROFESSIONAL ENGINEER:



APPLICANT:
SPORTS MEDICINE NORTH
ORTHOPEDIC SURGERY, INC.
C/O CONSERV GROUP, INC.
110 STATE ROAD
SAGAMORE BEACH, MASSACHUSETTS 02562

DRAWN BY: ESS
DESIGNED BY: ESS
CHECKED BY: BCM
APPROVED BY: BCM
DATE: MARCH 17, 2020
SCALE: 1" = 30'
PROJECT NO.: 219-180
DWG. TITLE:

LANDSCAPING PLAN

DWG. NO.:
LA-1

- NOTES:
- ALL SECTIONS SHALL BE DESIGNED FOR HS-20 LOADING.
 - PROVIDE "V" KNOCKOUTS FOR PIPES WITH 2" MAX. CLEARANCE TO OUTSIDE OF PIPE. MORTAR ALL PIPE CONNECTIONS.
 - JOINT SEALANT BETWEEN PRECAST SECTIONS SHALL BE PREFORMED BUTYL RUBBER.
 - CATCH BASIN FRAME AND GRATE SHALL BE SET IN FULL MORTAR BED. ADJUST TO GRADE WITH CLAY BRICK AND MORTAR (2 BRICK COURSES TYPICALLY, 5 BRICK COURSES MAXIMUM)

Hydro
International
Stormwater Solutions
94 Hutchins Drive
Portland, Maine 04102
Tel: (207) 756-6200
Fax: (207) 756-6212
stormwaterinquiry@hydro-int.com

MANHOLE WALL AND SLAB THICKNESS ARE NOT TO SCALE.

CONTACT HYDRO INTERNATIONAL FOR A BOTTOM OF STRUCTURE ELEVATION PRIOR TO SETTING FIRST DEFENSE MANHOLE.

CONTRACTOR TO CONFIRM RIM, PIPE INVERTS, PIPE DIA. AND PIPE ORIENTATION PRIOR TO RELEASING UNIT TO FABRICATION.

Parts List			
ITEM	QTY.	DESCRIPTION	SIZE (in)
1	3	I.D. CONCRETE MANHOLE	36
2	3	INLET CHUTE (W/ FLOATABLES TRAP)	
3	3	OUTLET CHUTE	
4	3	INLET PIPE (BY OTHERS)	12
5	3	OUTLET PIPE (BY OTHERS)	12
6	3	HIGH FLOW BYPASS	
7	3	FRAME AND COVER (OR GRATE)	

3' DIAMETER FIRST DEFENSE UNIT (FD-3HC)
N.T.S.

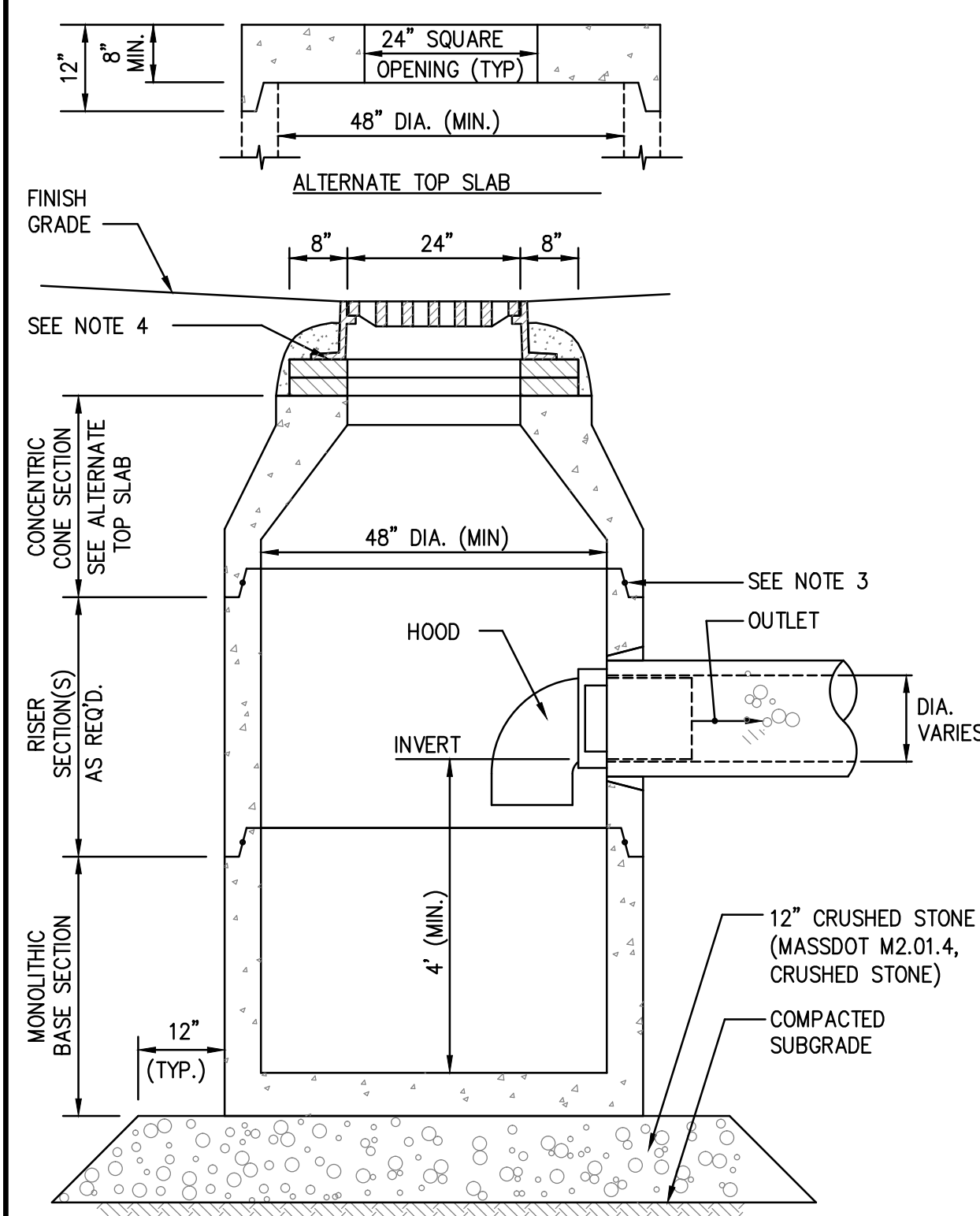

CATCH BASIN W/HOOD
SCALE: N.T.S.

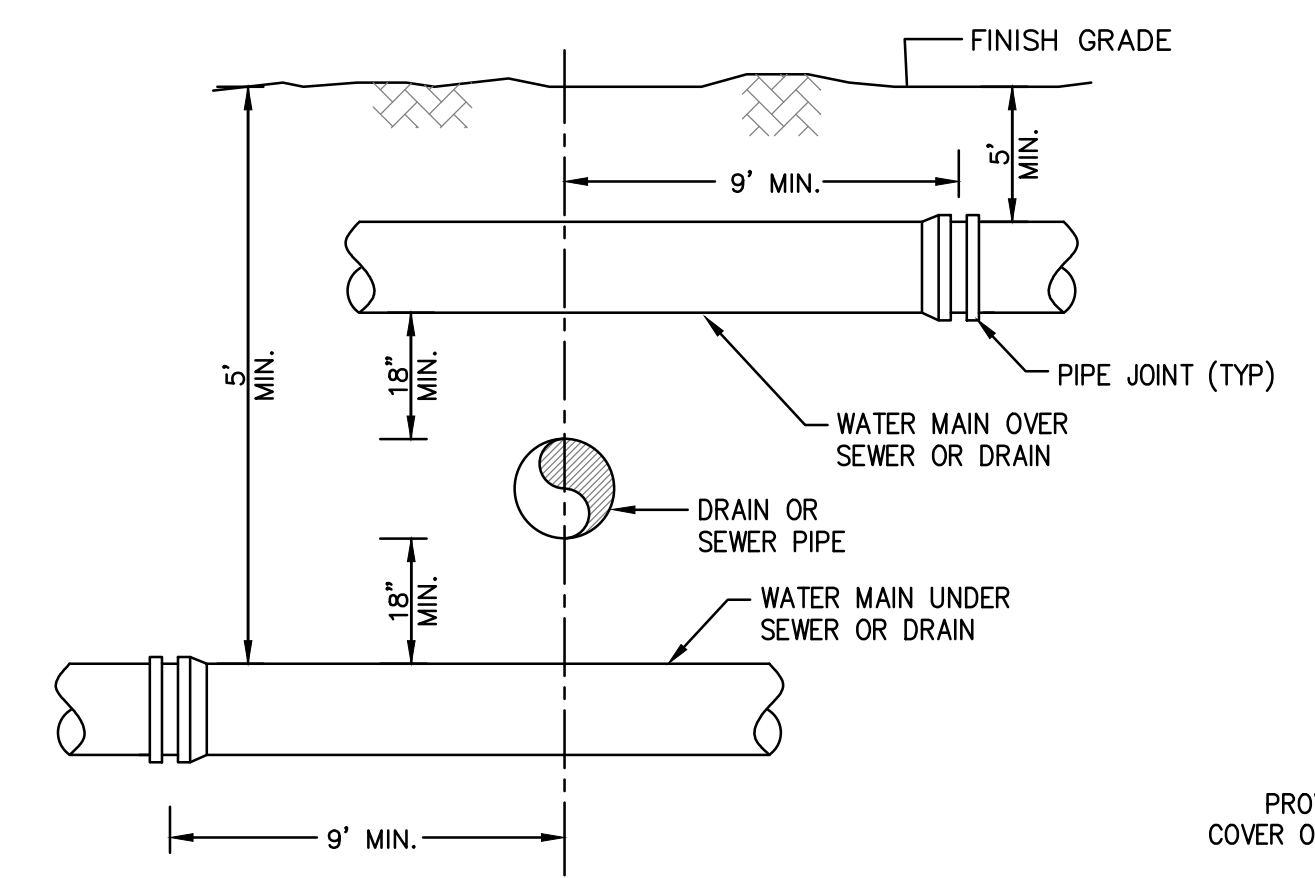

SEWER OR DRAIN CROSSING DETAIL
N.T.S.

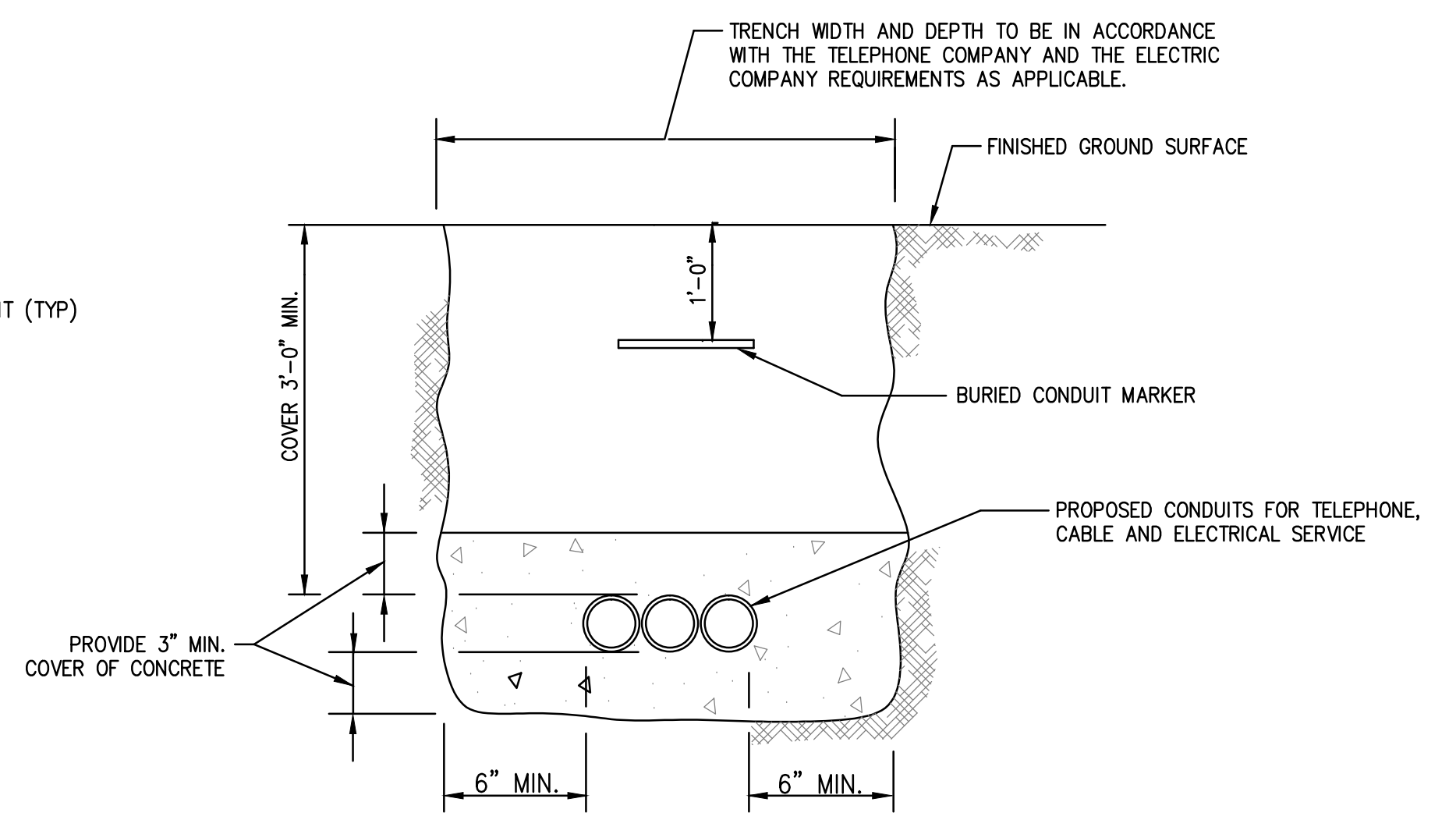

TYPICAL ELECTRIC/TELEPHONE/CABLE CONDUIT (US-UTILITY SERVICE)
SCALE: N.T.S.

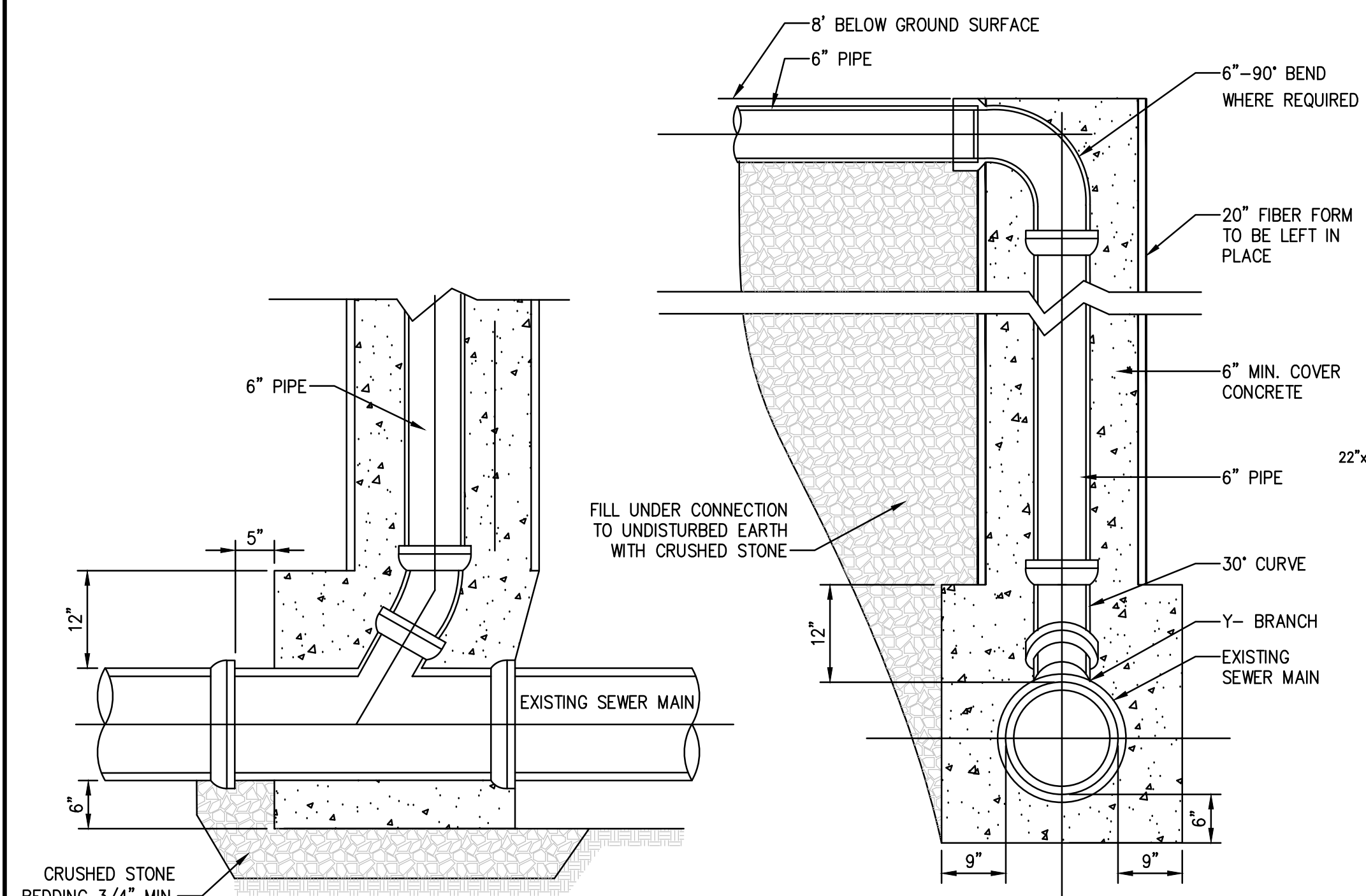

SEWER CHIMNEY CONNECTION
N.T.S.

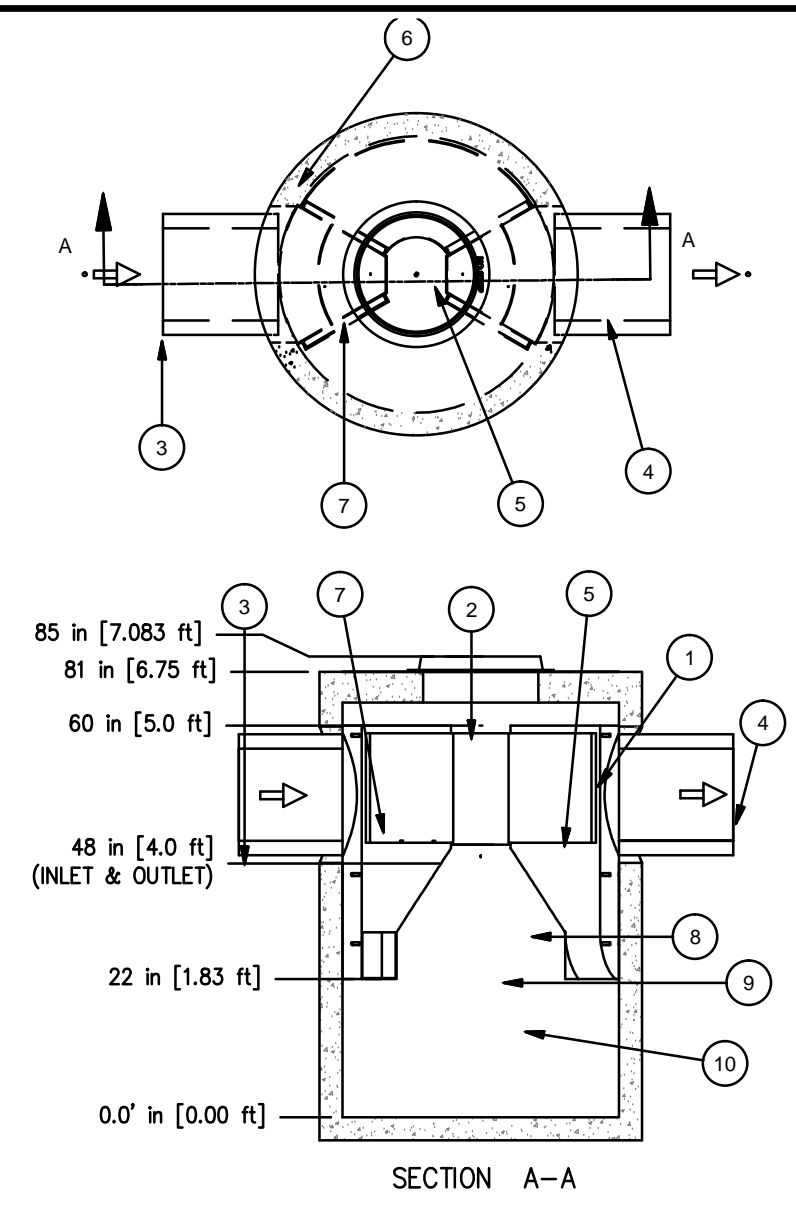

SECTION A-A

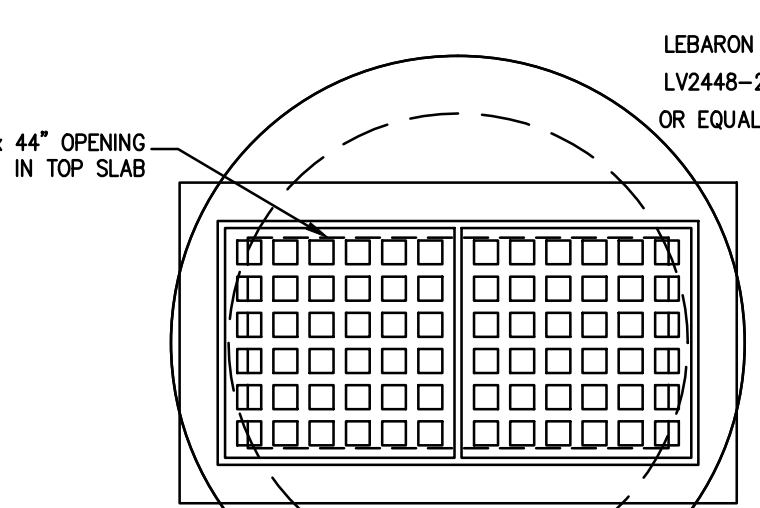

PLAN

DOUBLE GRATE CATCH BASIN DETAIL
SCALE: N.T.S.

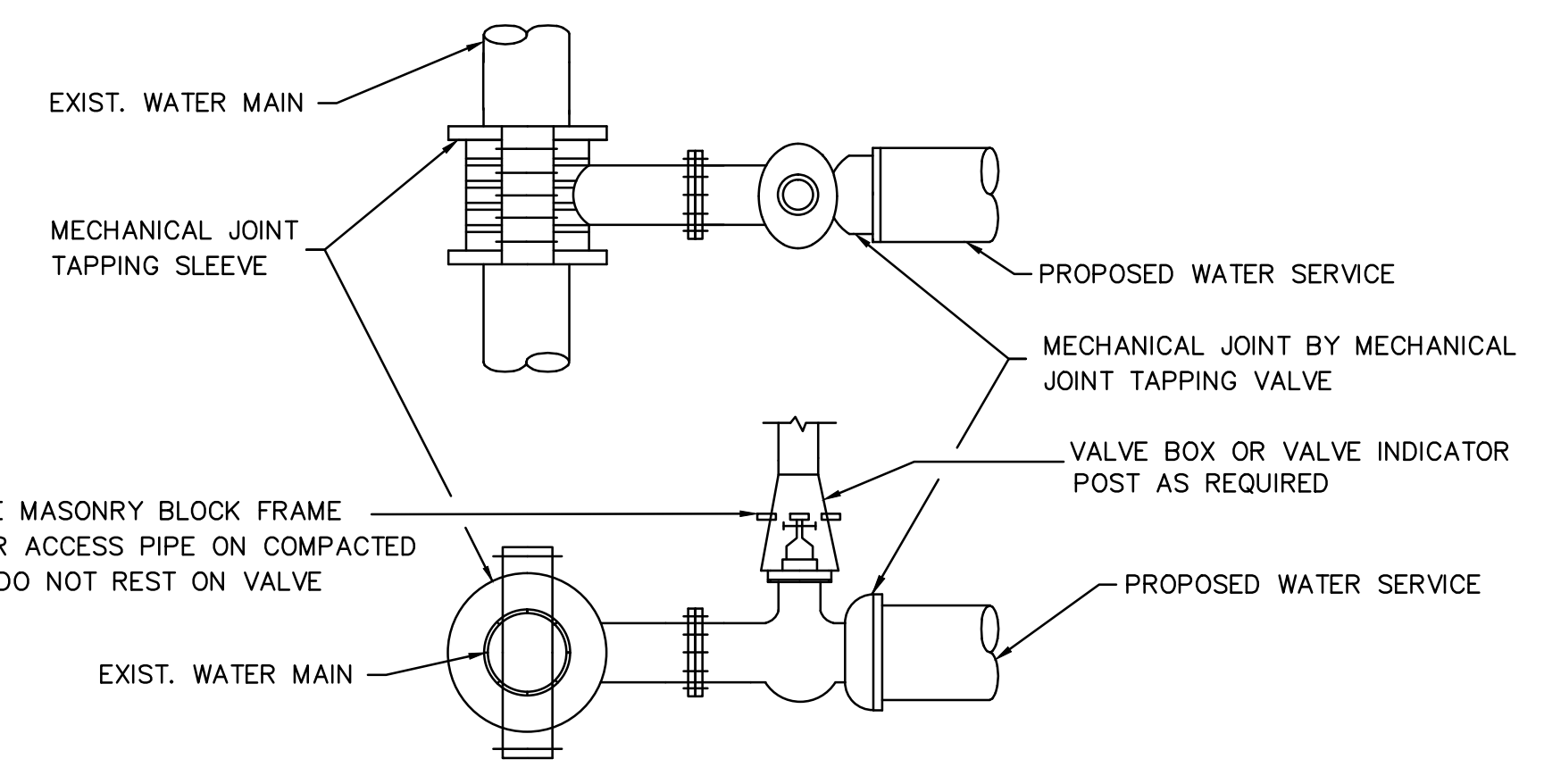

TYPICAL TAPPING SLEEVE AND VALVE
SCALE: N.T.S.

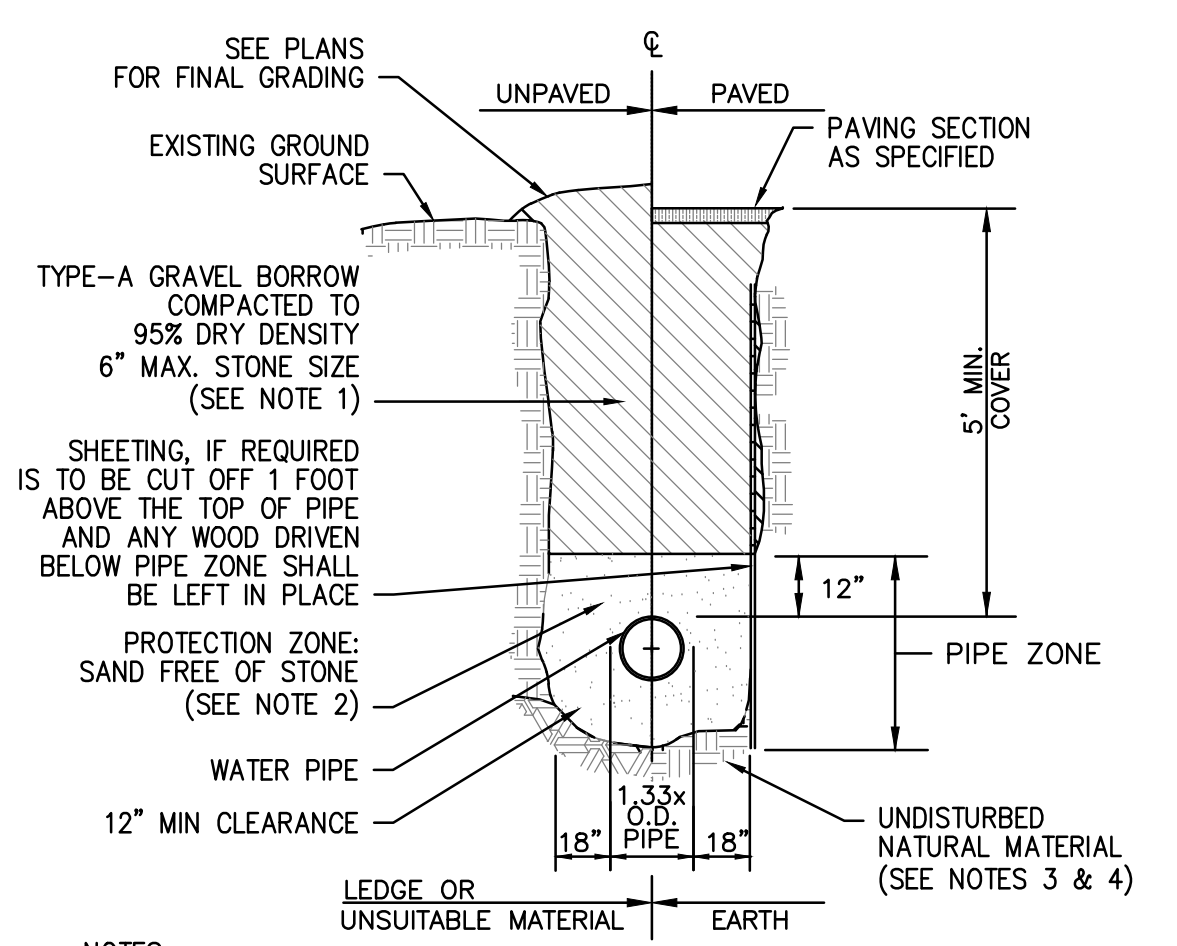

TYPICAL WATER TRENCH DETAIL
SCALE: N.T.S.

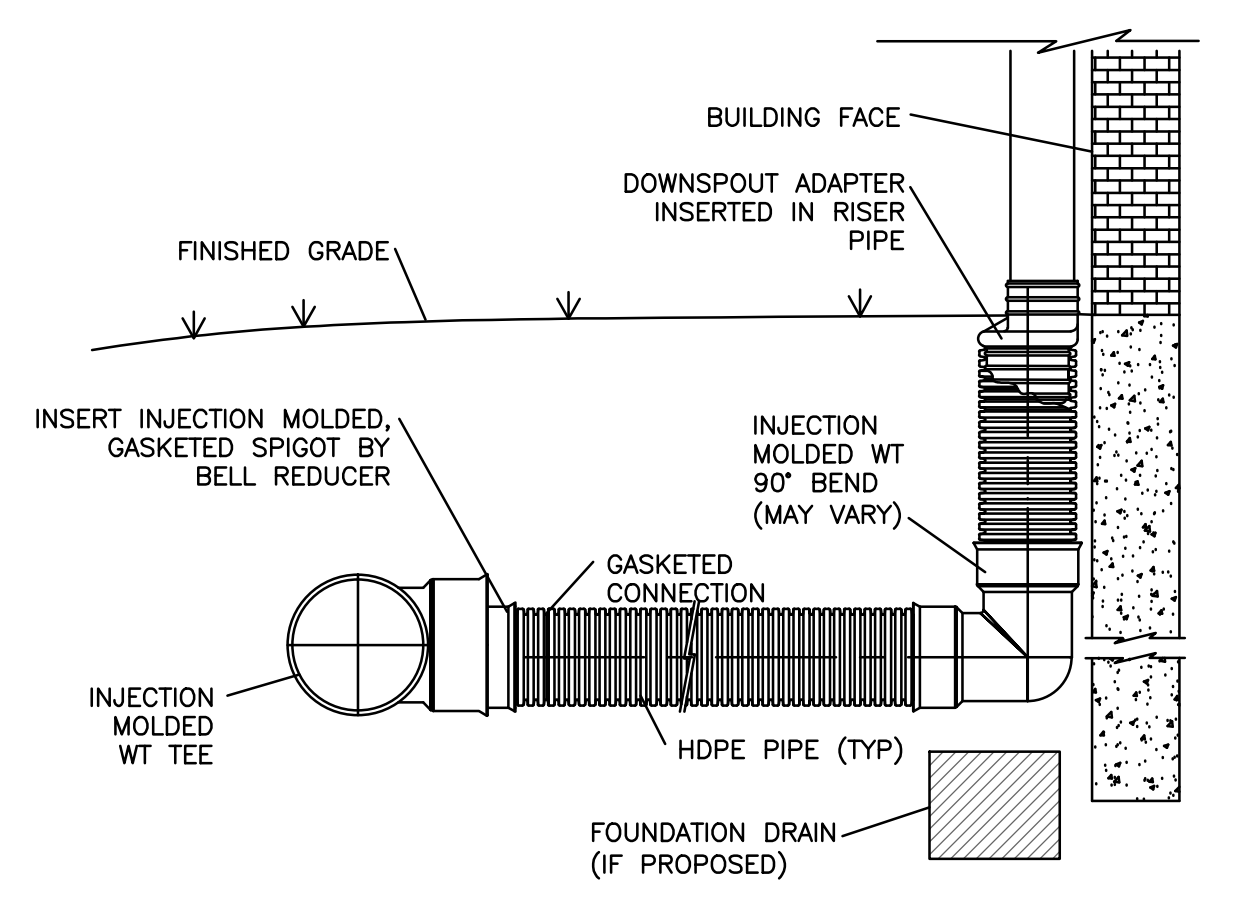

ROOF LEADER CONNECTION DETAIL
SCALE: N.T.S.

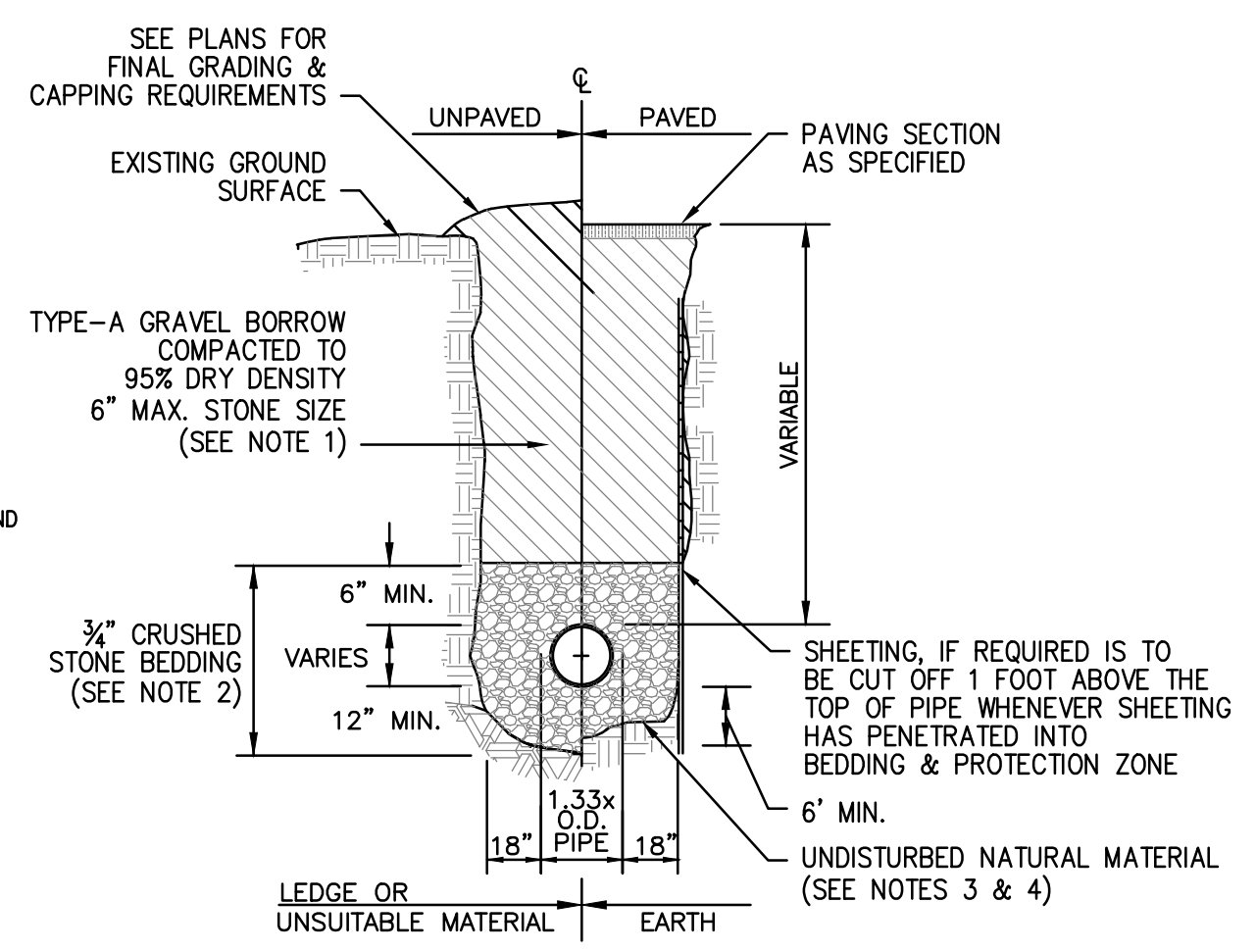

GRAVITY SEWER TRENCH DETAIL
SCALE: N.T.S.

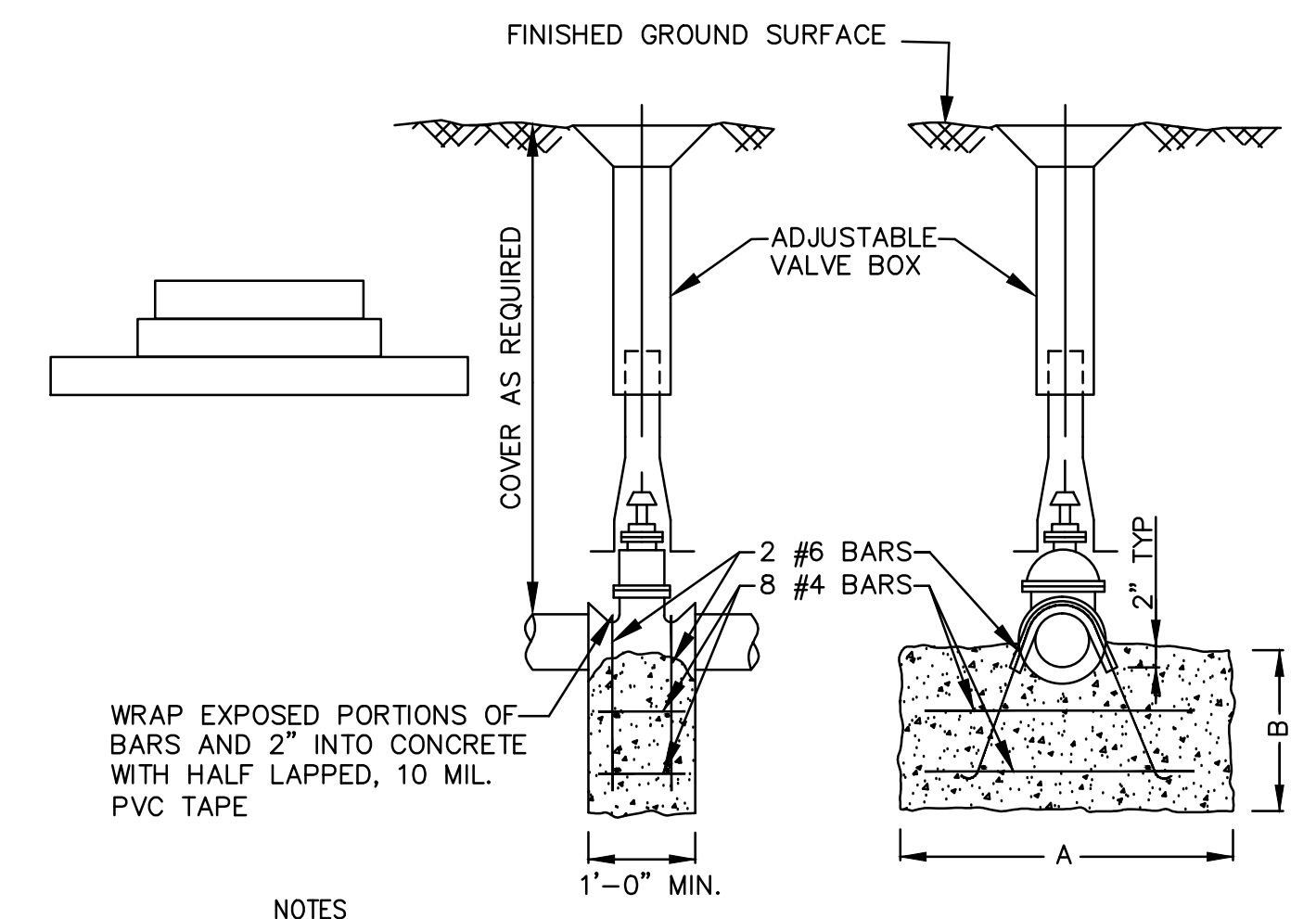

WATER GATE DETAIL
NOT TO SCALE

SIZE OF GATE VALVE	ANCHOR BLOCK DIMENSIONS (FT.)		
	A	B	
		200 PSI TEST	250 PSI TEST
3"	1.5	1.5	2.0
4"	2.0	1.5	2.0
6"	3.0	1.5	2.0
8"	3.0	1.5	2.0
10"	3.0	2.0	2.5
12"	3.5	2.0	2.5

- NOTES
- FLANGES, BOLTS, & NUTS SHALL BE KEPT CLEAR OF CONCRETE
 - VALVES SHALL OPEN TO THE RIGHT.

REV	DATE	DESCRIPTION
1	4/29/20	REVIEW COMMENTS

MG
MCKENZIE
ENGINEERING GROUP
Mississippi Office Park
150 Longwater Drive, Suite 101
Norwell, MA 02061
P: 781.792.3900
F: 781.792.0333
www.mckeng.com

**SITE DEVELOPMENT PLANS
PROPOSED MEDICAL BUILDING
20 HENRY GRAF JR. ROAD
NEWBURYPORT, MASSACHUSETTS**

PROFESSIONAL ENGINEER:

BRADLEY C. MCKENZIE
No. 38917
Professional Engineer

APPLICANT:
**SPORTS MEDICINE NORTH
ORTHOPEDIC SURGERY, INC.
C/O CONSERV GROUP, INC.**
110 STATE ROAD
SAGAMORE BEACH, MASSACHUSETTS 02562

DRAWN BY: ESS
DESIGNED BY: ESS
CHECKED BY: BCM
APPROVED BY: BCM
DATE: MARCH 17, 2020
SCALE:
PROJECT NO.: 219-180
DWG. TITLE:

**CONSTRUCTION
DETAILS**

DWG. NO.:
D-1

NOT FOR CONSTRUCTION

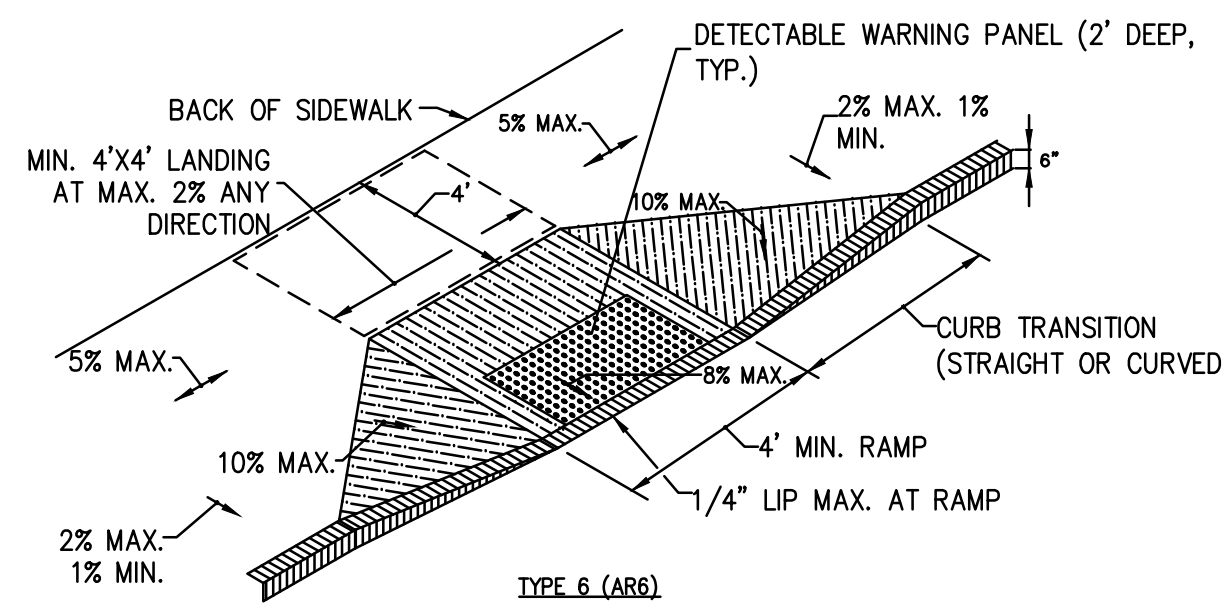
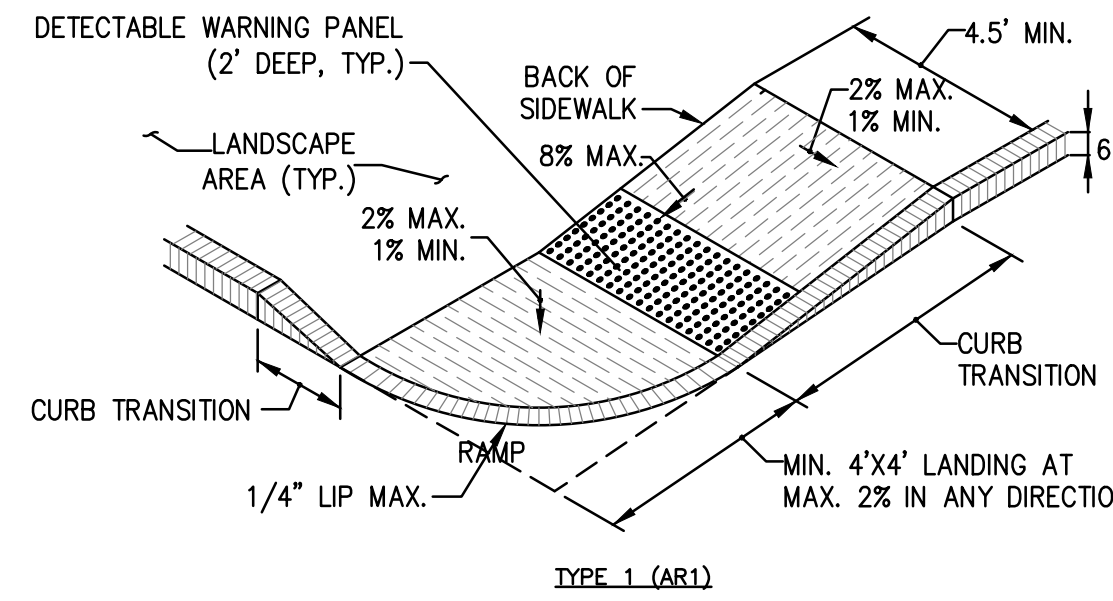
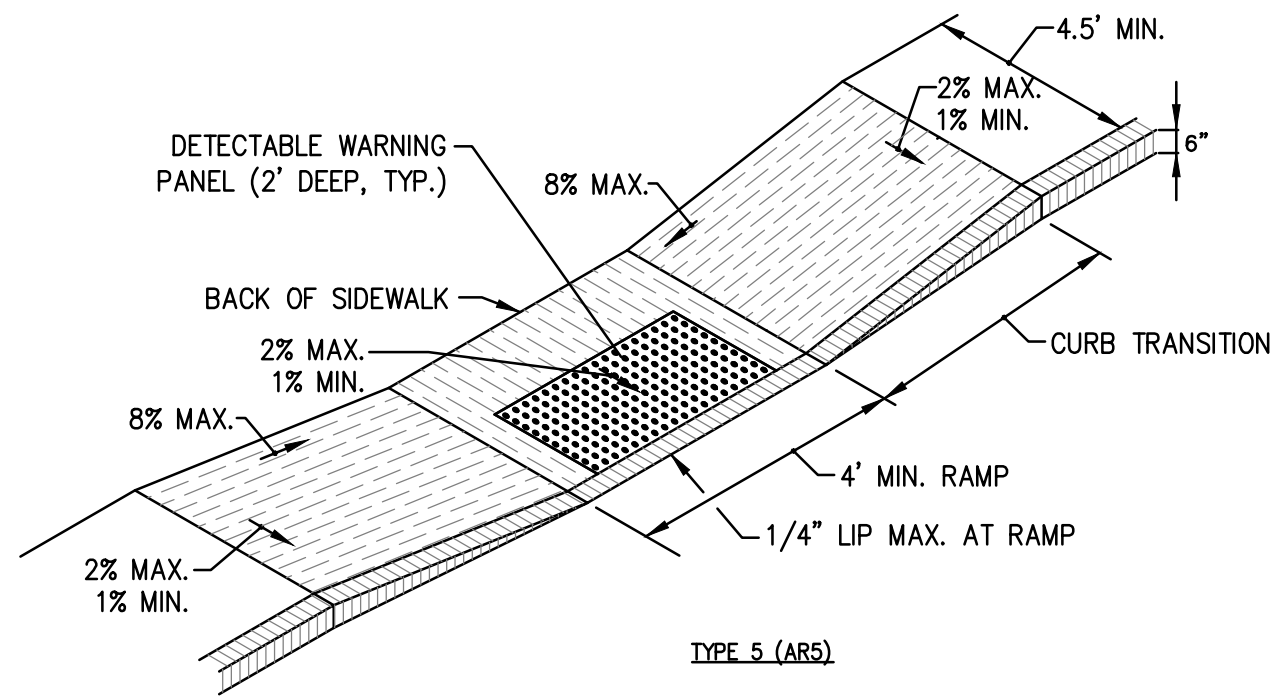

- NOTES:**
- SEE PLANS FOR CURB TYPE.
 - CURBS AND WALKS ALONG ACCESSIBLE ROUTES SHALL MEET OR EXCEED THE APPLICABLE REGULATIONS OF THE MASSACHUSETTS ARCHITECTURAL ACCESS BOARD, FAIR HOUSING ACT AND ADA.
 - THE MAXIMUM ALLOWABLE SIDEWALK AND CURB RAMP CROSS SLOPES SHALL BE 2%.
 - THE MAXIMUM ALLOWABLE SLOPE OF ACCESSIBLE ROUTE EXCLUDING CURB RAMP SHALL BE 5%.
 - THE MAXIMUM ALLOWABLE SLOPE OF ACCESSIBLE ROUTE CURB RAMP SHALL BE 8%.
 - MAINTAIN A MINIMUM OF 3 FEET CLEAR AT ANY PERMANENT OBSTACLE IN ACCESSIBLE ROUTE (I.E., HYDRANTS, UTILITY POLES, TREE WELLS, SIGNS ETC.).
 - GRADE BASE OF RAMP TO PREVENT PONDING.
 - RAMP CONSTRUCTION SHALL CONFORM TO TYPICAL SIDEWALK SECTION.
 - WHERE ACCESSIBLE ROUTES ARE LESS THAN 5' IN WIDTH (EXCLUDING CURBING) A 5'x5' PASSING AREA SHALL BE PROVIDED AT INTERVALS NOT TO EXCEED 200 FEET.
 - ALL CURBING AT RAMP SHALL BE VERTICAL CURBING SET FLUSH WHERE IT ABUTS ROADWAY.
 - ALL RAMP SHALL BE CEMENT CONCRETE OR BITUMINOUS CONCRETE WITH ROUGHENED NON-SLIP SURFACE.
 - ALL DETECTABLE WARNING PANELS SHALL BE PER TOWN OF NEWBURYPORT STANDARD DETAILS.
 - THE MATERIAL USED TO PROVIDE CONTRAST SHALL BE AN INTEGRAL PART OF THE WALKING SURFACE. DETECTABLE WARNINGS USED ON INTERIOR SURFACES SHALL DIFFER FROM ADJOINING WALKING SURFACES IN RESILIENCY OR SOUND-ON-CANE-CONTACT.

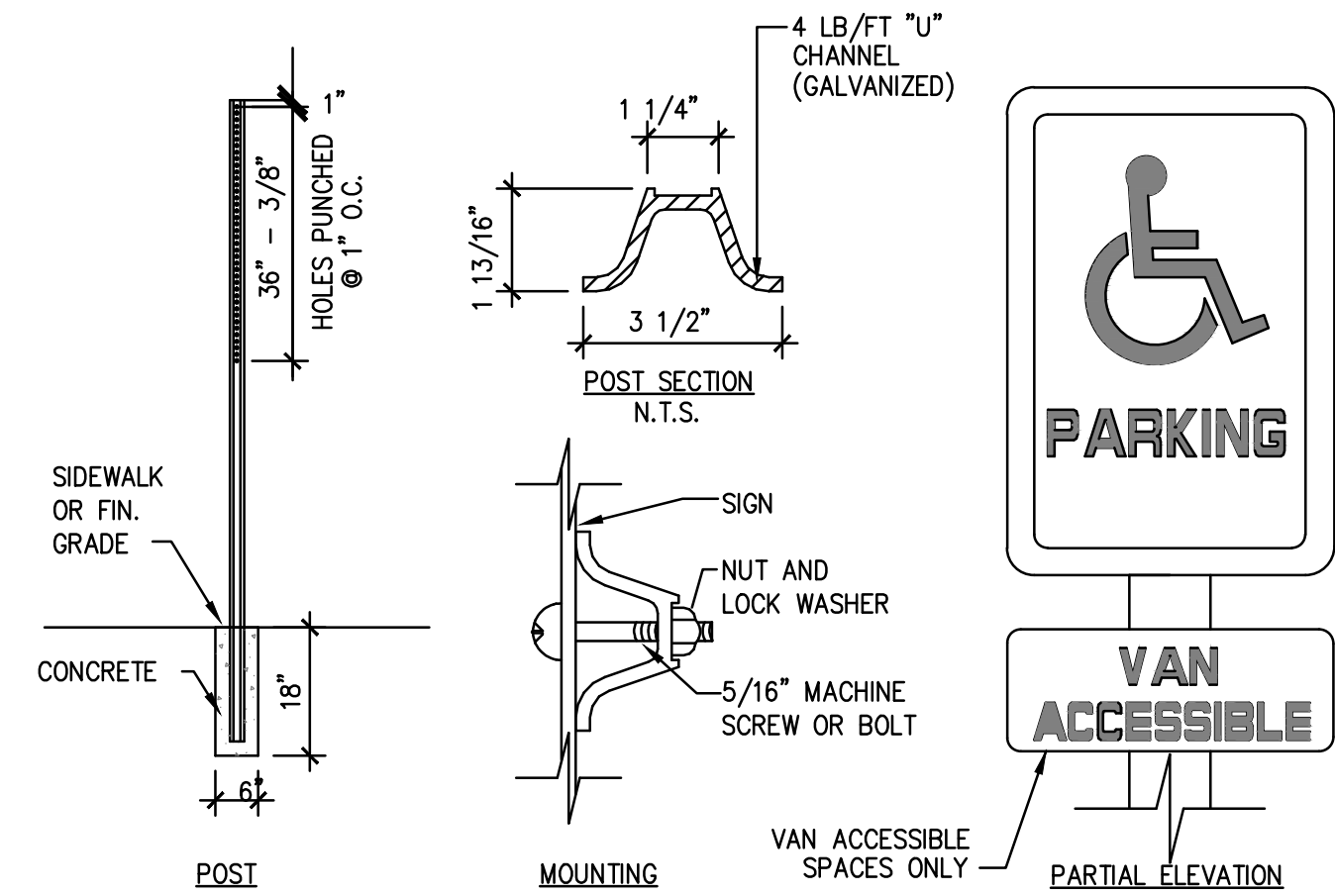

SIGN DETAIL
SCALE: N.T.S.

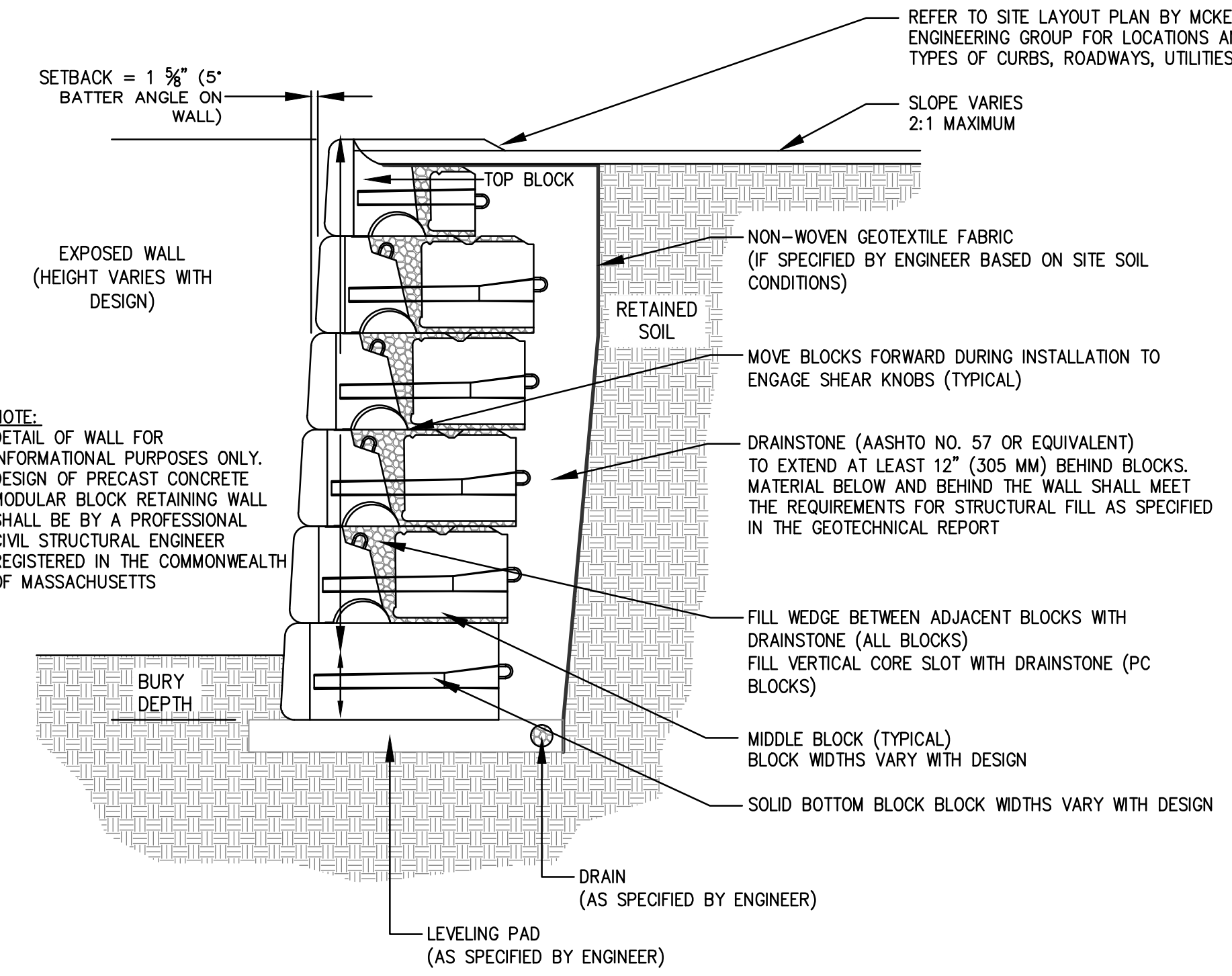
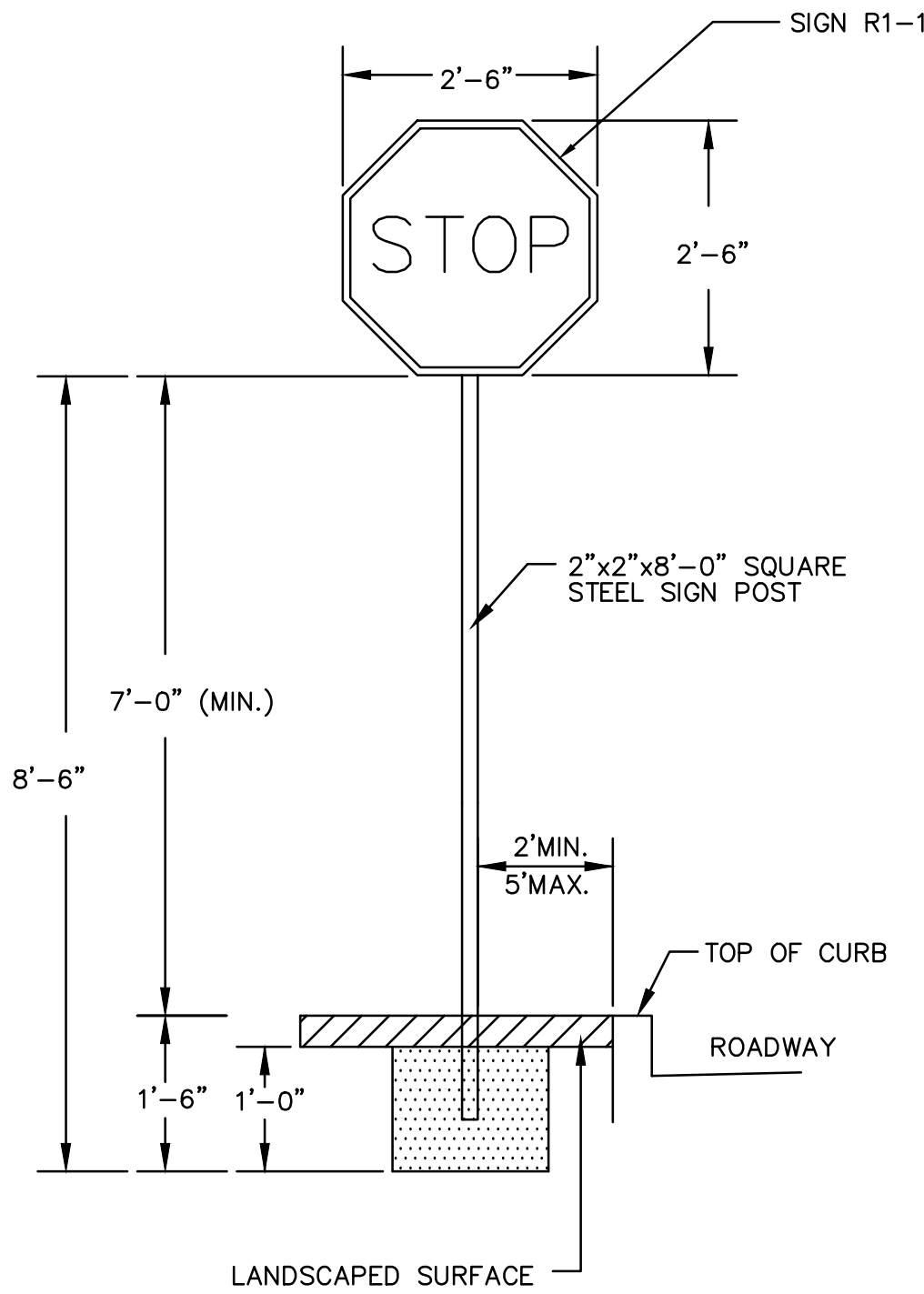

MODULAR BLOCK GRAVITY RETAINING WALL
SCALE: N.T.S.

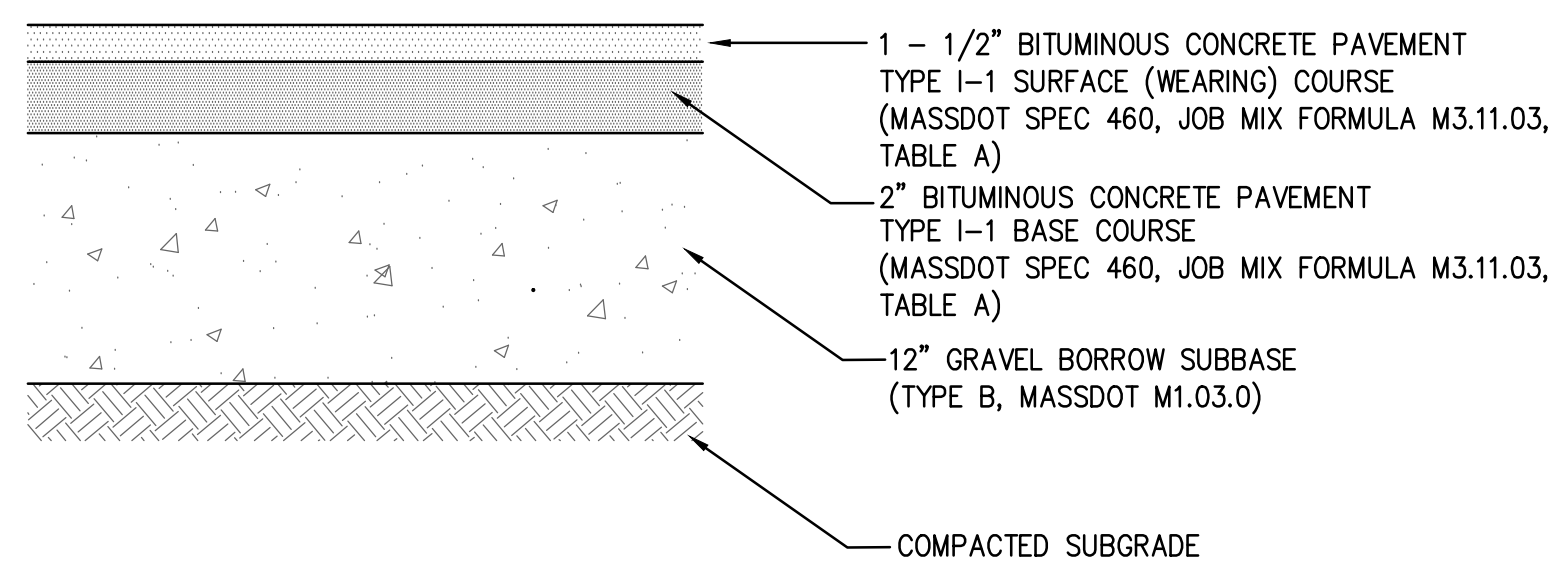

PARKING AREA PAVEMENT DETAIL

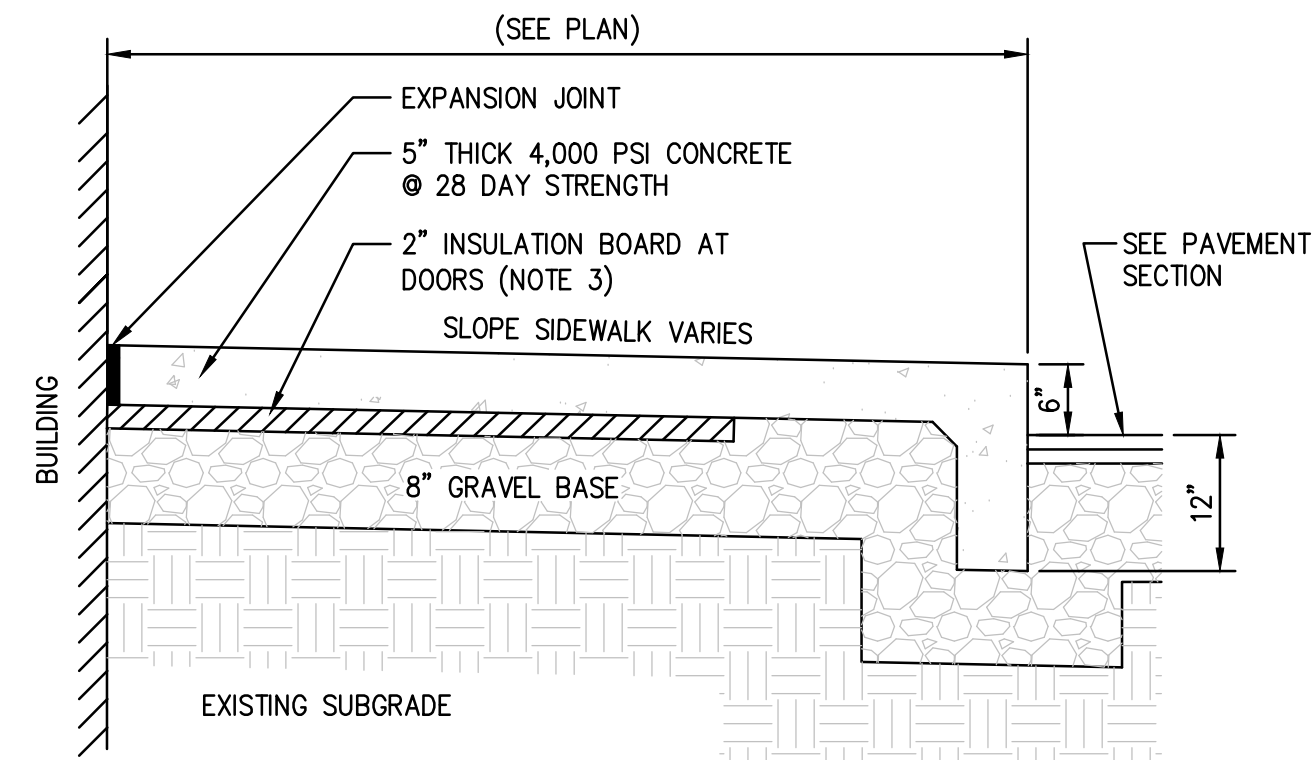

- NOTES:**
- SIDEWALK TO HAVE TOOLED JOINTS 5' O.C. (TYP.) WITH EXPANSION JOINTS 15' ON CENTER AND PREMOLDED FILLER.
 - TOOLED JOINT 6" FROM FACE OF CURB
 - PLACE 2" RIGID EXTRUDED STYROFOAM NONEXPANDABLE INSULATION BOARD LIGHT BLUE IN COLOR AT DOORS. BOARD TO BE PLACED IN 2'-2'x8" SECTIONS CENTERED ON AND EXTENDING 4' PERPENDICULAR FROM DOOR. BASE MATERIAL SHALL BE CRUSHED STONE AT DOORS.
 - SEE PLAN FOR ELEVATIONS AT DOORS AND CURB

CONCRETE SIDEWALK AND MONOLITHIC CURB AT BUILDING
SCALE: N.T.S.

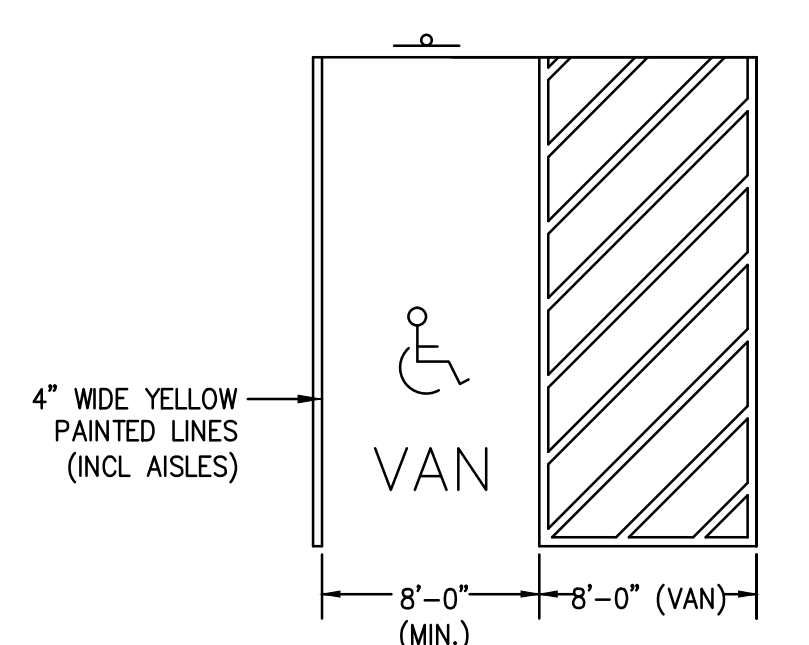

HANDICAP PARKING STALL DETAIL
SCALE: N.T.S.

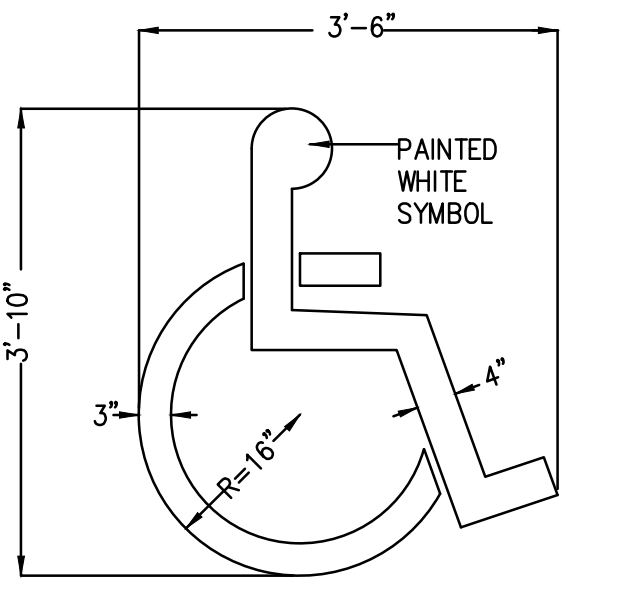

PAINTED HANDICAP SYMBOL DETAIL
SCALE: N.T.S.

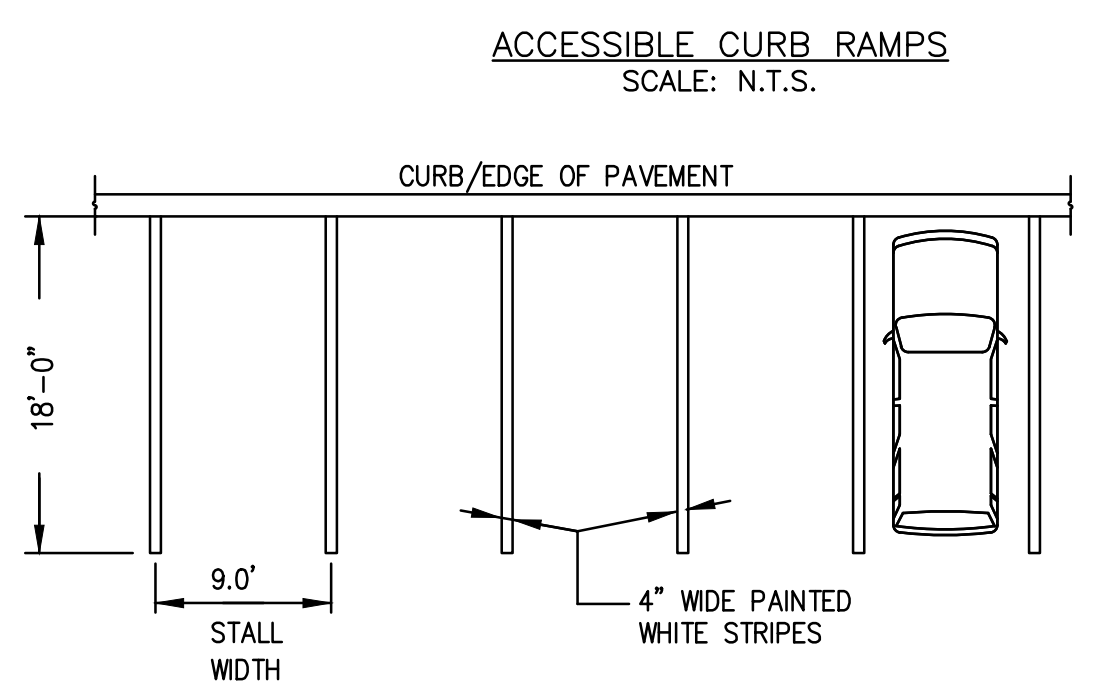

STANDARD SPACE TYPICAL STRIPING DETAILS
SCALE: N.T.S.

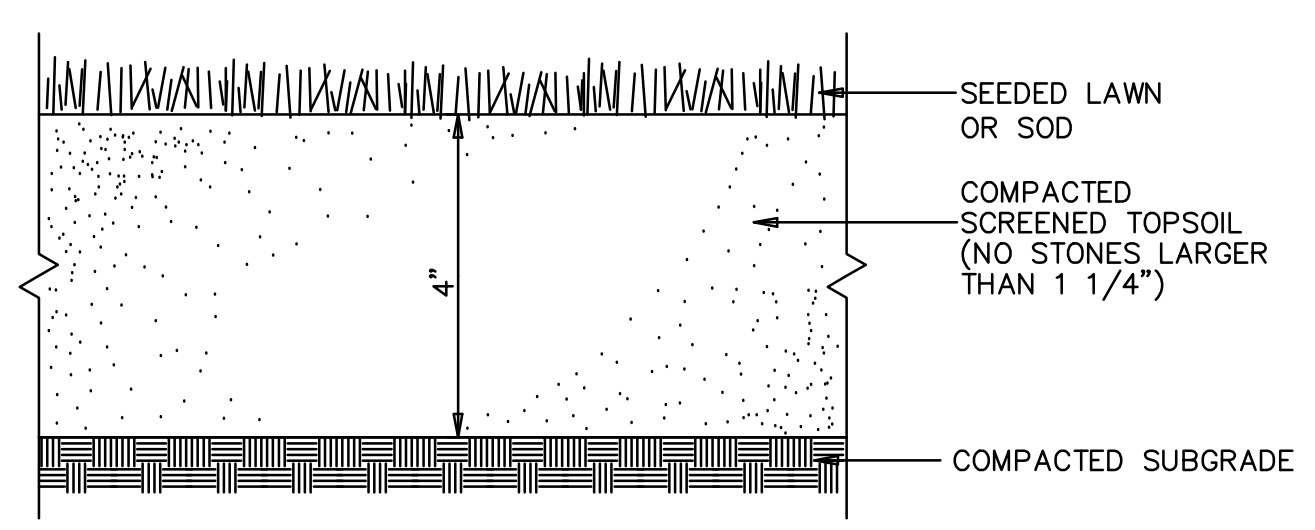

SEEDED OR SODDED LAWN DETAIL
SCALE: N.T.S.

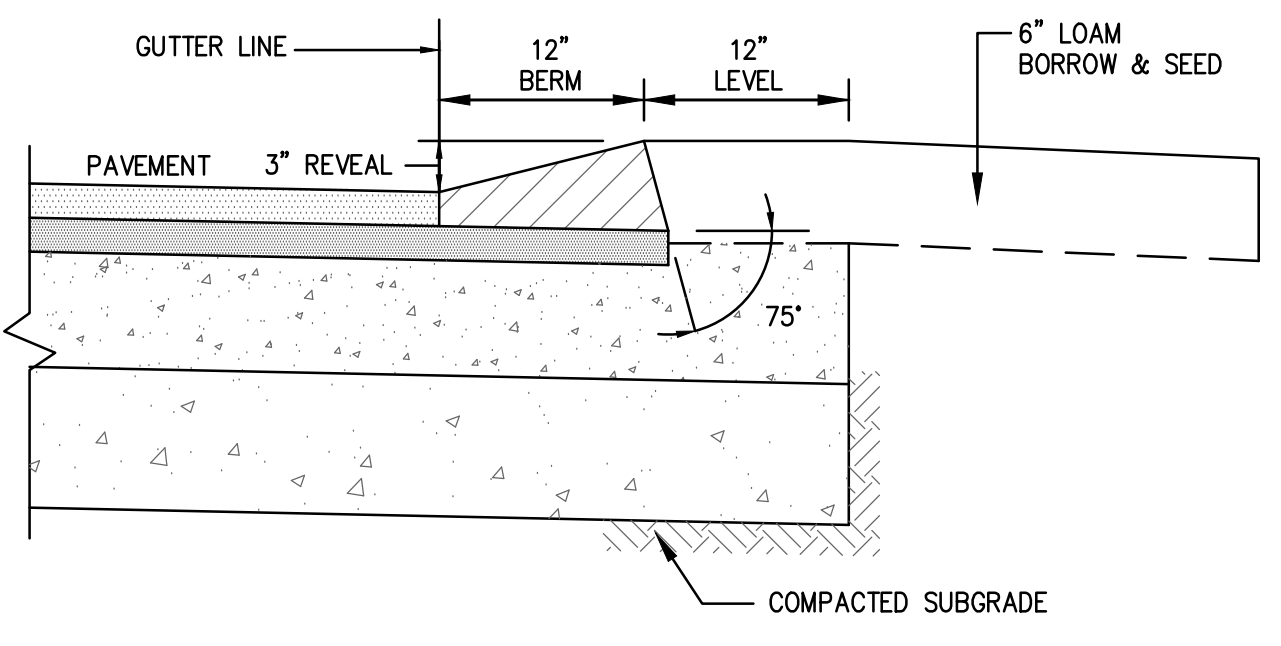

MONOLITHIC BITUMINOUS CONCRETE BERM (CAPE COD BERM) DETAIL
SCALE: N.T.S.

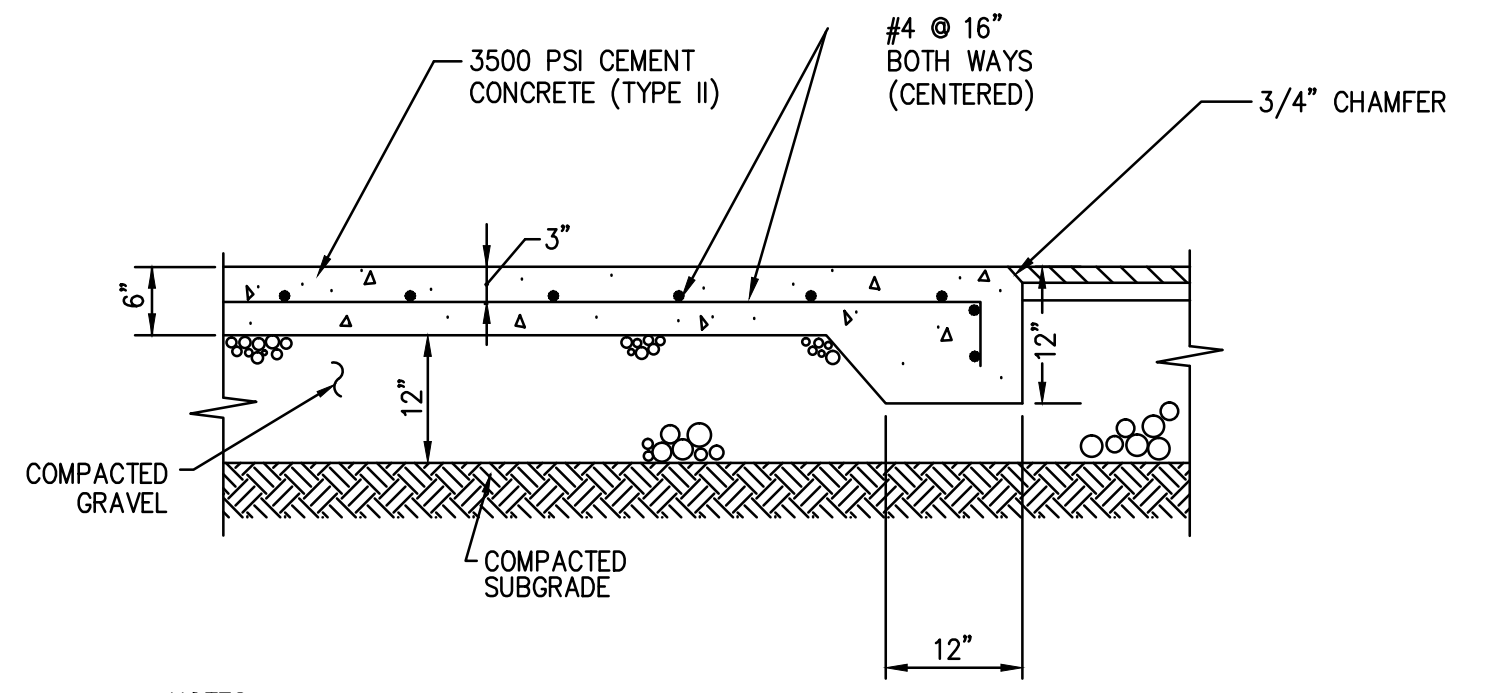

- NOTES:**
- SIZE OF PAD TO BE AS INDICATED ON PLANS. CONSTRUCTION JOINTS TO BE SET AT INTERVALS OF 1/3 OF LENGTH.

CEMENT CONCRETE PAD DETAIL
SCALE: N.T.S.

REV	DATE	DESCRIPTION
1	4/29/20	REVIEW COMMENTS

MG
MCKENZIE
ENGINEERING GROUP
Assinippi Office Park
150 Longwater Drive, Suite 101
Norwell, MA 02061
P: 781.792.3900
F: 781.792.0333
www.mckeng.com

**SITE DEVELOPMENT PLANS
PROPOSED MEDICAL BUILDING
20 HENRY GRAF JR. ROAD
NEWBURYPORT, MASSACHUSETTS**

PROFESSIONAL ENGINEER:

APPLICANT:
**SPORTS MEDICINE NORTH
ORTHOPEDIC SURGERY, INC.
C/O CONSERV GROUP, INC.**
110 STATE ROAD
SAGAMORE BEACH, MASSACHUSETTS 02562

DRAWN BY:	ESS
DESIGNED BY:	ESS
CHECKED BY:	BCM
APPROVED BY:	BCM
DATE:	MARCH 10, 2020
SCALE:	
PROJECT NO.:	219-180
DWG. TITLE:	

**CONSTRUCTION
DETAILS**

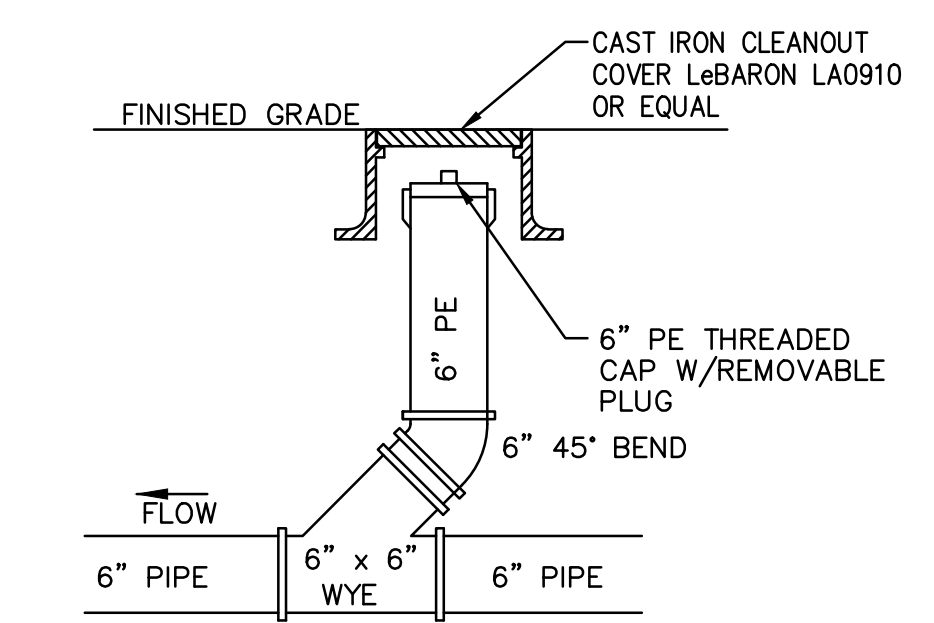

NOTE:
1. CLEANOUT SHOWN ABOVE IS FOR 6" PIPE. PROPOSED CLEANOUTS VARY IN SIZE AND THE APPURTENANCES SHALL ALSO VARY ACCORDINGLY.

CLEANOUT DETAIL
SCALE: N.T.S.

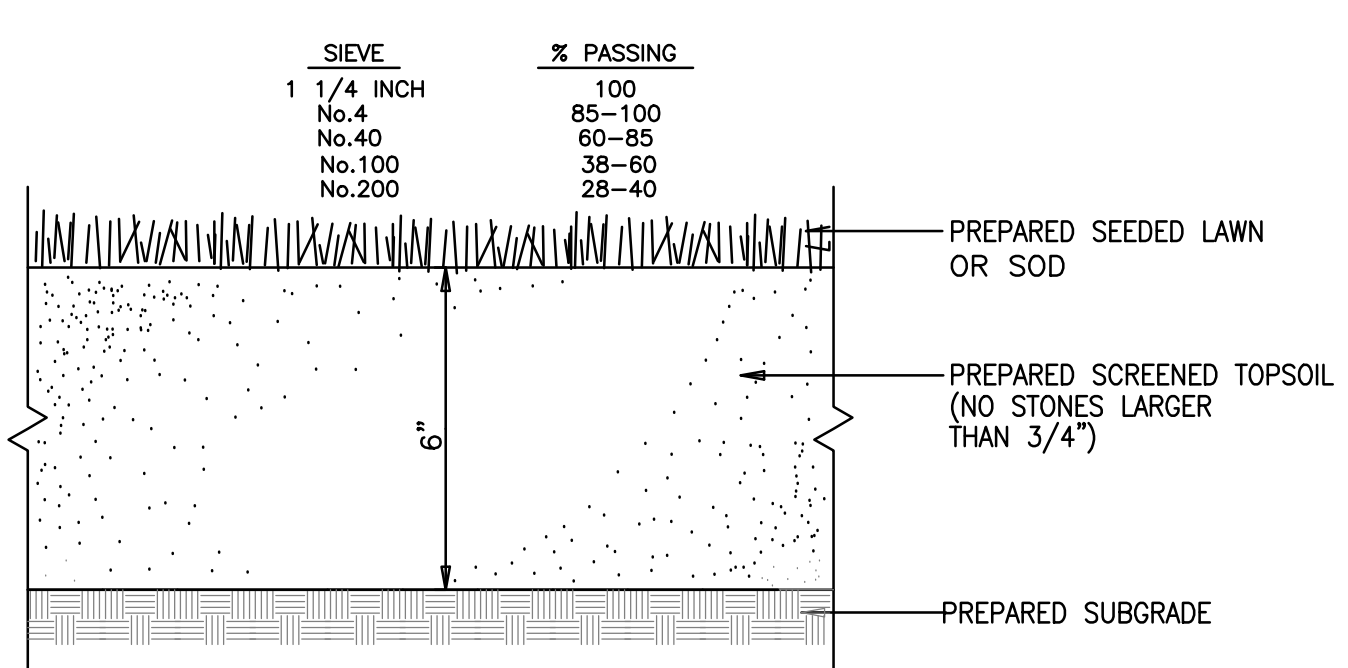

SEEDED OR SODDED LAWN DETAIL
SCALE: N.T.S.

SEEDING SPECIFICATIONS

- SEEDING RECOMMENDATIONS
- SEEDBED PREPARATION
 - SURFACE AND SEEPAGE WATER SHOULD BE DRAINED OR DIVERTED FROM THE SITE TO PREVENT DROWNING OR WINTER KILLING OF THE PLANTS.
 - STONES LARGER THAN FOUR INCHES AND TRASH SHOULD BE REMOVED BECAUSE THEY INTERFERE WITH SEEDING AND FUTURE MAINTENANCE OF THE AREA. WHERE FEASIBLE, THE SOIL SHOULD BE TILLED TO A DEPTH OF ABOUT FOUR INCHES TO PREPARE A SEEDBED AND MIX FERTILIZER AND LIME INTO THE SOIL. THE SEEDBED SHOULD BE LEFT IN A REASONABLY FIRM AND SMOOTH CONDITION. THE LAST TILLAGE OPERATION SHOULD BE PERFORMED ACROSS THE SLOPE WHEREVER PRACTICAL.
 - ESTABLISHING A STAND
 - LIME AND FERTILIZER SHOULD BE APPLIED PRIOR TO OR AT THE TIME OF SEEDING AND INCORPORATED INTO THE SOIL. KINDS AND AMOUNTS OF LIME AND FERTILIZER SHOULD BE BASED ON EVALUATION OF SOIL TESTS. WHEN A SOIL TEST IS NOT AVAILABLE, THE FOLLOWING MINIMUM AMOUNTS SHOULD BE APPLIED:
 AGRICULTURAL LIMESTONE: 2 TONS PER ACRE OR 100 LBS. PER SQ. FT.
 NITROGEN (N): 50 LBS. PER ACRE OR 1.1 LBS. PER 1000 SQ. FT.
 PHOSPHATE (P O₂): 5 100 LBS. PER ACRE OR 2.2 LBS. PER 1000 SQ. FT.
 POTASH (K O₂): 100 LBS. PER ACRE OR 2.2 LBS. PER 1000 SQ. FT.
 (NOTE: THIS IS THE EQUIVALENT OF 500 LBS. PER ACRE OF 10-20-20 FERTILIZER OF 1,000 LBS. PER ACRE OF 5-10-10)
 - SEED SHOULD BE SPREAD UNIFORMLY BY THE METHOD MOST APPROPRIATE FOR THE SITE. METHODS INCLUDE BROADCASTING, DRILLING, AND HYDROSEEDING. WHERE BROADCASTING IS USED, COVER SEED WITH 0.25 INCH OF SOIL OR LESS, BY CULTIPACKING OR RAKING.
 - REFER TO SEEDING RATES AND SEEDING GUIDES FOR APPROPRIATE SEED MIXTURES AND RATES OF SEEDING.
 - WHEN SEEDED AREAS ARE MULCHED, PLANTINGS MAY BE MADE FROM EARLY SPRING SPRING TO EARLY OCTOBER. WHEN SEEDED AREAS ARE NOT MULCHED, PLANTINGS SHOULD BE MADE FROM EARLY SPRING TO MAY 20 OR FROM AUGUST 10 TO SEPTEMBER 1.
 - MULCH
 - HAY, STRAW, OR OTHER MULCH, WHEN NEEDED, SHOULD BE APPLIED IMMEDIATELY AFTER SEEDING.
 - MULCH WILL BE HELD IN PLACE USING TECHNIQUES AS SPECIFIED IN THE "BEST MANAGEMENT PRACTICES OPERATION AND MAINTENANCE PLAN"
 - MAINTENANCE TO ESTABLISH A STAND
 - PLANTED AREAS SHOULD BE PROTECTED FROM DAMAGE BY FIRE, GRAZING, TRAFFIC, AND DENSE WEED GROWTH.
 - FERTILIZATION NEEDS SHOULD BE DETERMINED BY ONSITE INSPECTIONS. SUPPLEMENTAL FERTILIZER IS USUALLY THE KEY TO FULLY COMPLETE THE ESTABLISHMENT OF THE STAND BECAUSE MOST PERENNIALS TAKE 2 TO 3 YEARS TO BECOME ESTABLISHED.
 - IN WATERWAYS, CHANNELS, OR SWALES WHERE UNIFORM FLOW CONDITIONS ARE ANTICIPATED OCCASIONAL MOWING MAY BE NECESSARY TO CONTROL GROWTH OF WOODY VEGETATION.

NOTES:
1. TOP OF LOAM (TOPSOIL) IS FINISHED GRADE.
2. TOPSOIL SHALL CONTAIN BETWEEN 5% AND 12% ORGANIC MATTER AND SHALL HAVE A MAXIMUM STONE SIZE OF 3/4" AND SHALL CONFORM TO THE FOLLOWING GRADATION:

SEEDING RATES

	POUND / ACRE	POUNDS / 1,000 S.F.
A. TALL FESCUE	20	0.45
CREEPING RED FESCUE	20	0.45
REDTOP	2	0.05
TOTAL	42	0.95
B. TALL FESCUE	15	0.35
CREEPING RED FESCUE	10	0.25
BIRDSFOOT TREFOIL	15	0.35
TOTAL	40	0.95
C. TALL FESCUE	20	0.45
CREEPING RED FESCUE	20	0.45
BIRDSFOOT TREFOIL	8	0.20
TOTAL	48	1.10
D. BIRDSFOOT TREFOIL	10	0.25
REDTOP	5	0.10
REED CANARY GRASS	15	0.35
TOTAL	30	0.70
E. TALL FESCUE	20	0.45
FLATPEA	30	0.75
TOTAL	50	1.20
F. CREEPING RED FESCUE 1/	85	2.00
KENTUCKY BLUEGRASS 1/	85	2.00
TOTAL	170	4.00
G. TALL FESCUE 1/	150	3.60

TEMPORARY SEEDING RATES

H. WINTER RYE	112	2.50	(BEST FOR FALL SEEDING, AUG 15 TO SEPT. 5)
OATS	80	2.00	(BEST FOR SPRING SEEDING, BEFORE MAY 15)
ANNUAL RYEGRASS	40	1.00	(BEST FOR FALL SEEDING, AUG 15 TO SEPT. 15) (MAY BE USED EARLY SPRING ALSO)

1/ FOR HEAVY USE ATHLETIC FIELDS CONSULT THE UNIVERSITY OF NEW HAMPSHIRE COOPERATIVE EXTENSION TURF SPECIALIST FOR CURRENT VARIETIES AND SEEDING RATES.

SEEDING GUIDE

USE	SEEDING MIXTURE 1/
STEEP CUTS AND FILLS, BORROW AND DISPOSAL AREAS	E
WATERWAYS, EMERGENCY SPILLWAYS, AND OTHER CHANNELS WITH FLOWING WATER	D
LAWN AREAS	F

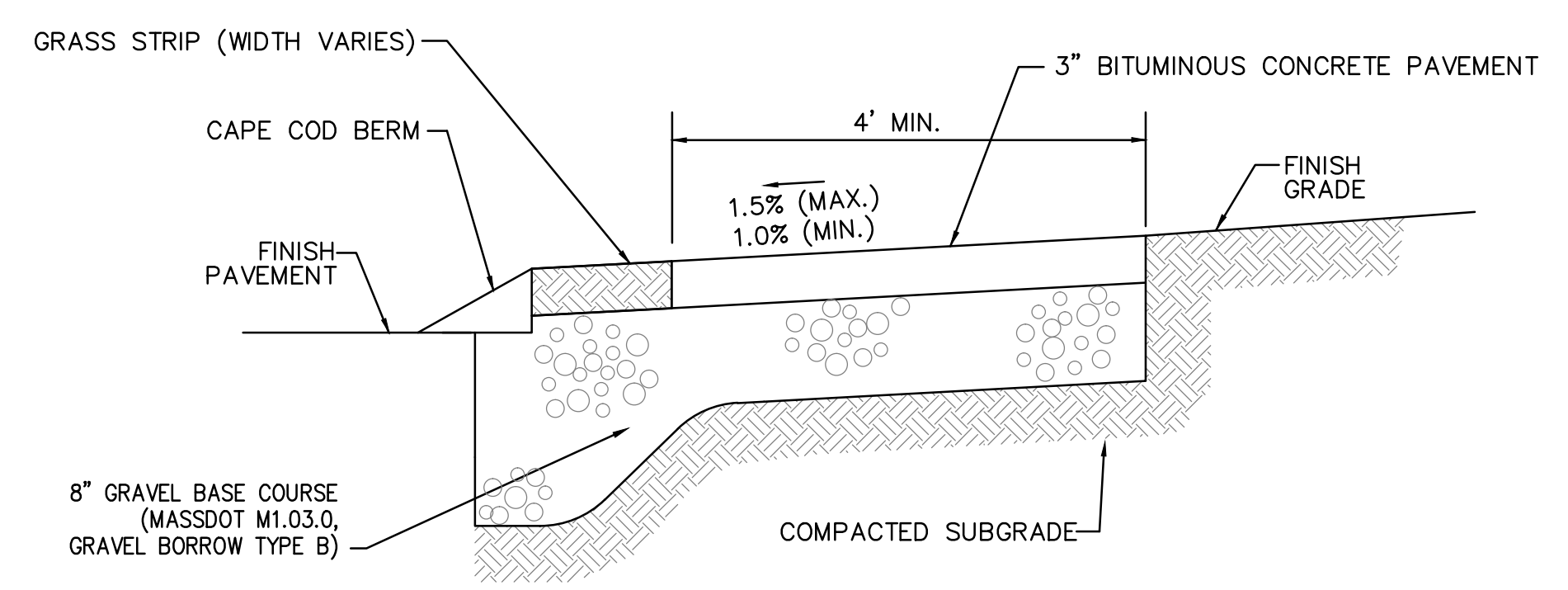

NOTES:
1. ALL WORK SHALL COMPLY WITH TOWN OF NEWBURYPORT SPECIFICATION FOR BITUMINOUS CONCRETE SIDEWALKS. LATEST REVISION.
2. SUBGRADE SHALL CONSIST OF NATIVE SOIL OR IMPORTED SOIL CONFORMING TO MASSDOT SPECIFICATION FOR ORDINARY BORROW AND SHALL BE FREE OF ANY UNSUITABLE MATERIALS.

BITUMINOUS CONCRETE SIDEWALK DETAIL
SCALE: N.T.S.

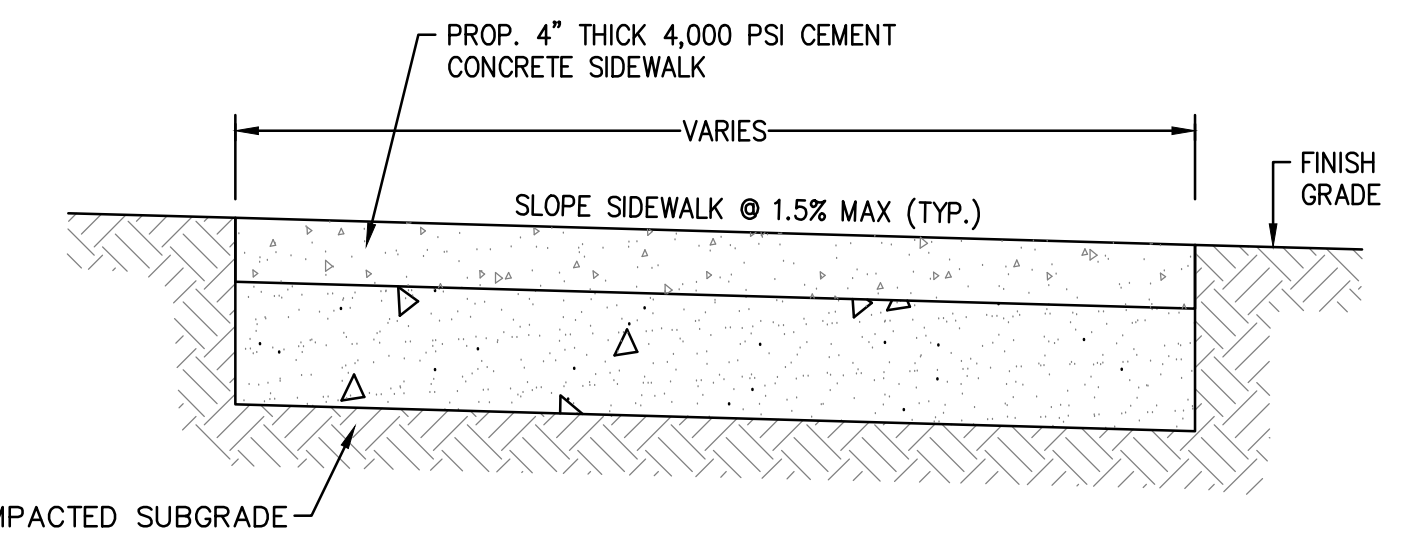

NOTES:
1. ALL WORK SHALL COMPLY WITH TOWN OF NEWBURYPORT SPECIFICATION FOR PORTLAND CEMENT CONCRETE SIDEWALKS. LATEST REVISION.
2. SUBGRADE SHALL CONSIST OF NATIVE SOIL OR IMPORTED SOIL CONFORMING TO MASSDOT SPECIFICATION FOR ORDINARY BORROW AND SHALL BE FREE OF ANY UNSUITABLE MATERIALS.
3. PROP. 6" THICK 4,000 PSI CEMENT CONCRETE AT ALL DRIVEWAYS AND ACCESSIBLE RAMPS.
4. ALL CONCRETE SHALL BE BROOM FINISHED WITHOUT TOOLING MARKS.

CEMENT CONCRETE SIDEWALK DETAIL
N.T.S.

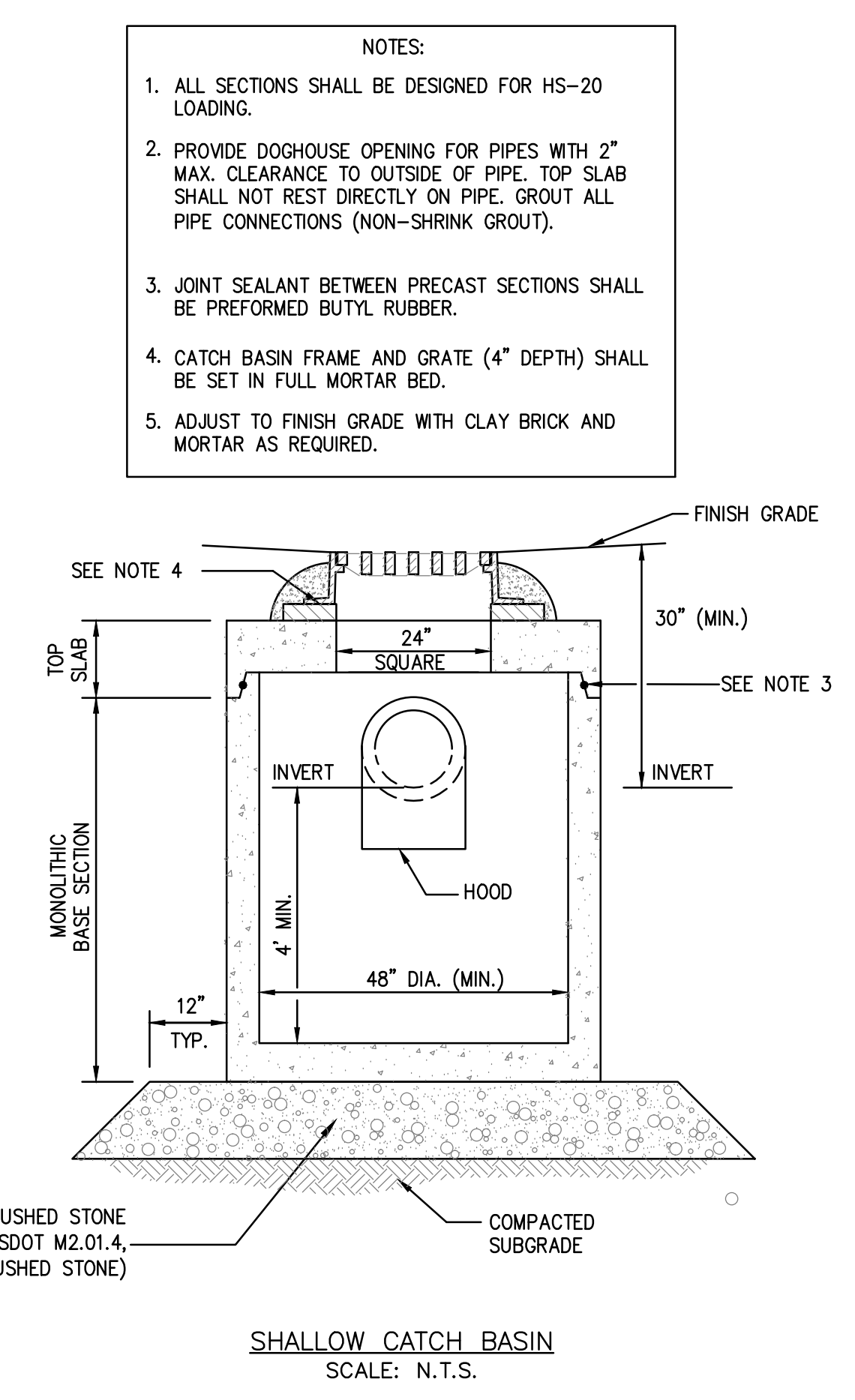

SHALLOW CATCH BASIN
SCALE: N.T.S.

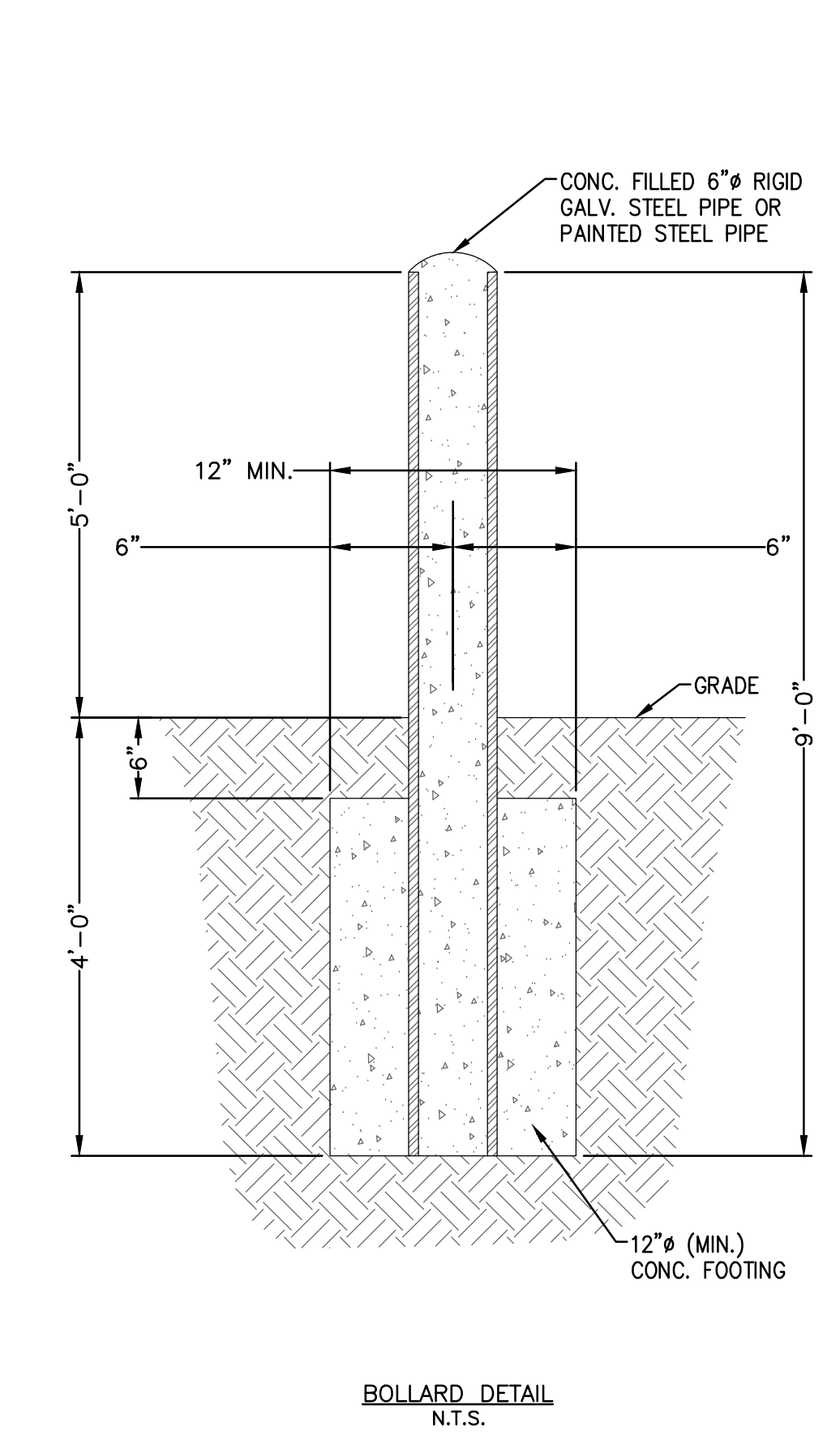

BOLLARD DETAIL
N.T.S.

REV	DATE	DESCRIPTION	BY	APP
1	4/29/20	REVIEW COMMENTS	ESS	BCM



SITE DEVELOPMENT PLANS
PROPOSED MEDICAL BUILDING
20 HENRY GRAF JR. ROAD
NEWBURYPORT, MASSACHUSETTS

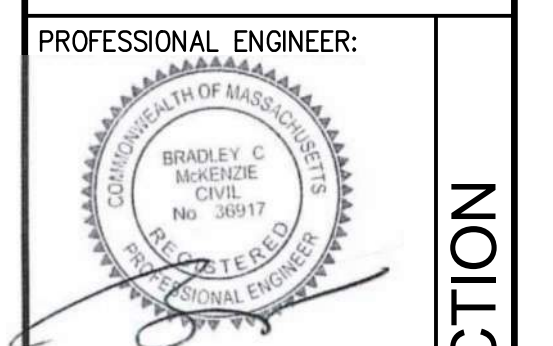

APPLICANT:
SPORTS MEDICINE NORTH
ORTHOPEDIC SURGERY, INC.
C/O CONSERV GROUP, INC.
110 STATE ROAD
SAGAMORE BEACH, MASSACHUSETTS 02562

DRAWN BY: ESS
DESIGNED BY: ESS
CHECKED BY: BCM
APPROVED BY: BCM
DATE: MARCH 17, 2020
SCALE:
PROJECT NO.: 219-180
DWG. TITLE:

CONSTRUCTION
DETAILS

DWG. NO.:
D-3

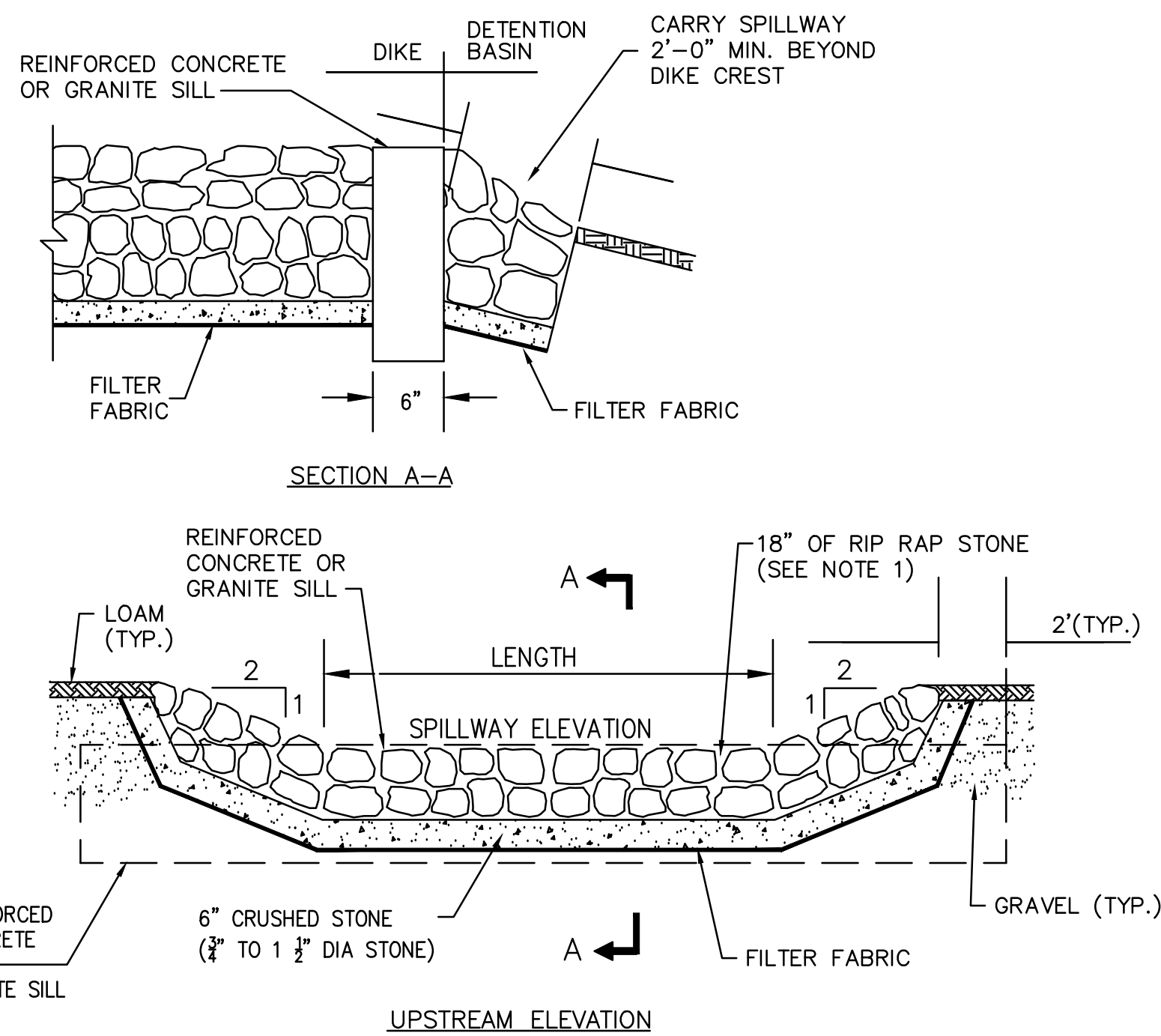

SPILLWAY SCHEDULE

BASIN	SPILLWAY ELEV.	LENGTH	100-YR FLOOD ELEV.
#1	14.35	6 FT	13.97
#2	14.50	2 FT	14.92

NOTE:
1. RIP RAP TO BE HAND CHINKED WITH A SMOOTH SURFACE ALONG THE TOP OF THE DIKE AND A ROUGH SURFACE ALONG THE DOWNSTREAM FACE AND TOE OF THE DIKE. STONE TO MEET M2.02.3 REQUIREMENTS.

SPILLWAY DETAIL
SCALE: N.T.S.

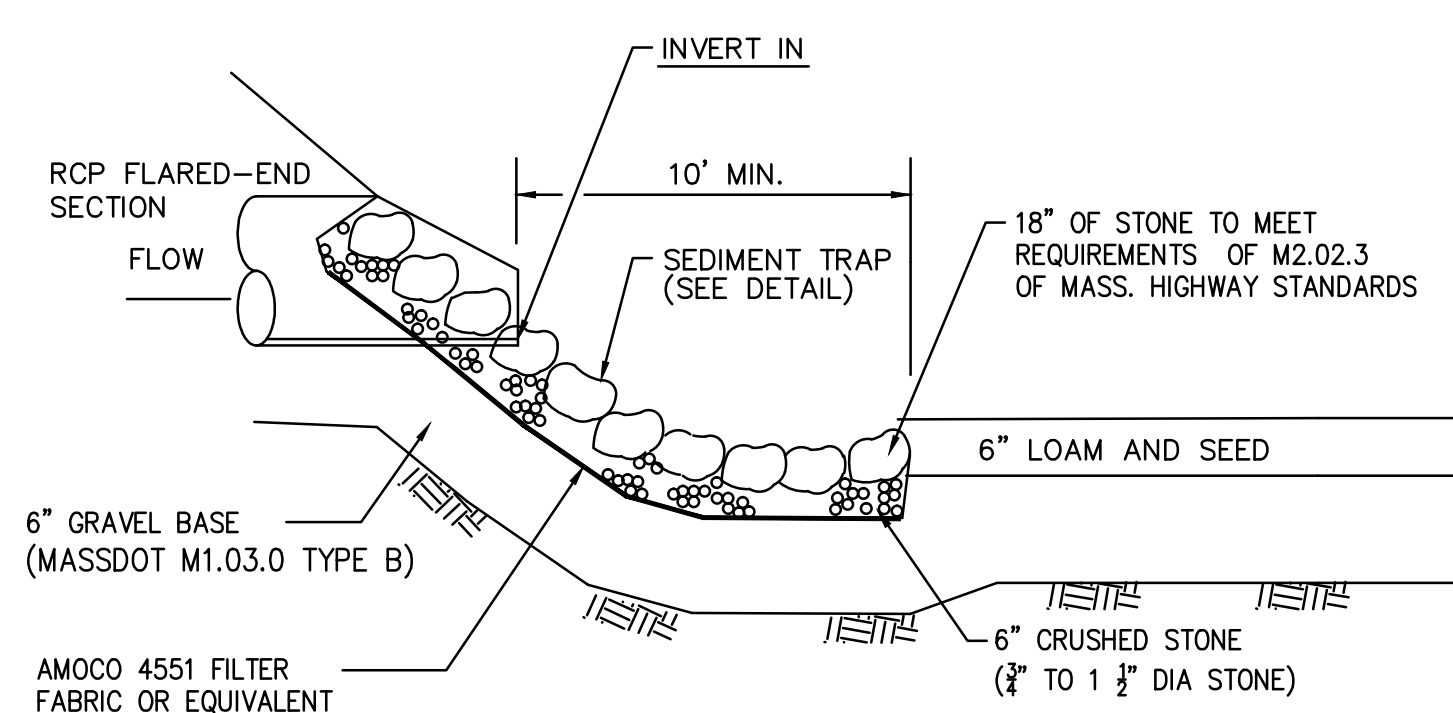

INFILTRATION BASIN SCHEDULE

	BASIN #1	BASIN #2	
APPROX. EXISTING GRADE	15.50	16.30	APPROX. EXISTING GRADE
INVERT IN STORM ELEV.	13.80/13.50/13.27	14.10	INVERT IN STORM ELEV.
100-YR STORM	13.97	14.92	100-YR STORM
25-YR STORM	13.70	14.79	25-YR STORM
10-YR STORM	13.56	14.73	10-YR STORM
2-YR STORM	13.27	14.60	2-YR STORM
TOP OF DIKE	15.00	16.00	TOP OF DIKE

- NOTES:**
- FILL AND BASE FOR DIKES SHALL INSURE WATER TIGHTNESS AND STABILITY.
 - BASIN SIDE SLOPES AND BOTTOM SHALL BE PROVIDED WITH 6" OF LOAMY SAND, SEEDED AT A RATE OF 2 POUNDS OF RED TOP, 15 POUNDS OF CREEPING RED FESCUE AND 20 POUNDS TALL FESCUE PER ACRE.
 - THE CONTRACTOR SHALL NOT DISCHARGE SEDIMENT-LADEN WATER TO DETENTION BASIN COMPONENTS DURING CONSTRUCTION, INCLUDING DEWATERING OR TEMPORARY SURFACE RUNOFF.
 - ALL CONTRIBUTING AREAS TO THE BASIN SHALL BE FULLY STABILIZED PRIOR TO THE BASIN BEING PLACED INTO SERVICE.
 - THE CONTRACTOR SHALL PROVIDE PROTECTION ABOVE AND AROUND THE DETENTION AREA OF THE BASIN FROM CONSTRUCTION VEHICLE ACTIVITY. NO HEAVY EQUIPMENT SHALL BE ALLOWED ON THE BASIN FLOORS AFTER INSTALLATION. CONTRACTOR SHALL MINIMIZE CONSTRUCTION EQUIPMENT TRAFFIC WITHIN THE BASIN AT ALL TIMES DURING AND AFTER CONSTRUCTION.

DETENTION BASIN SECTION (BASIN #1, #2)
SCALE: N.T.S.

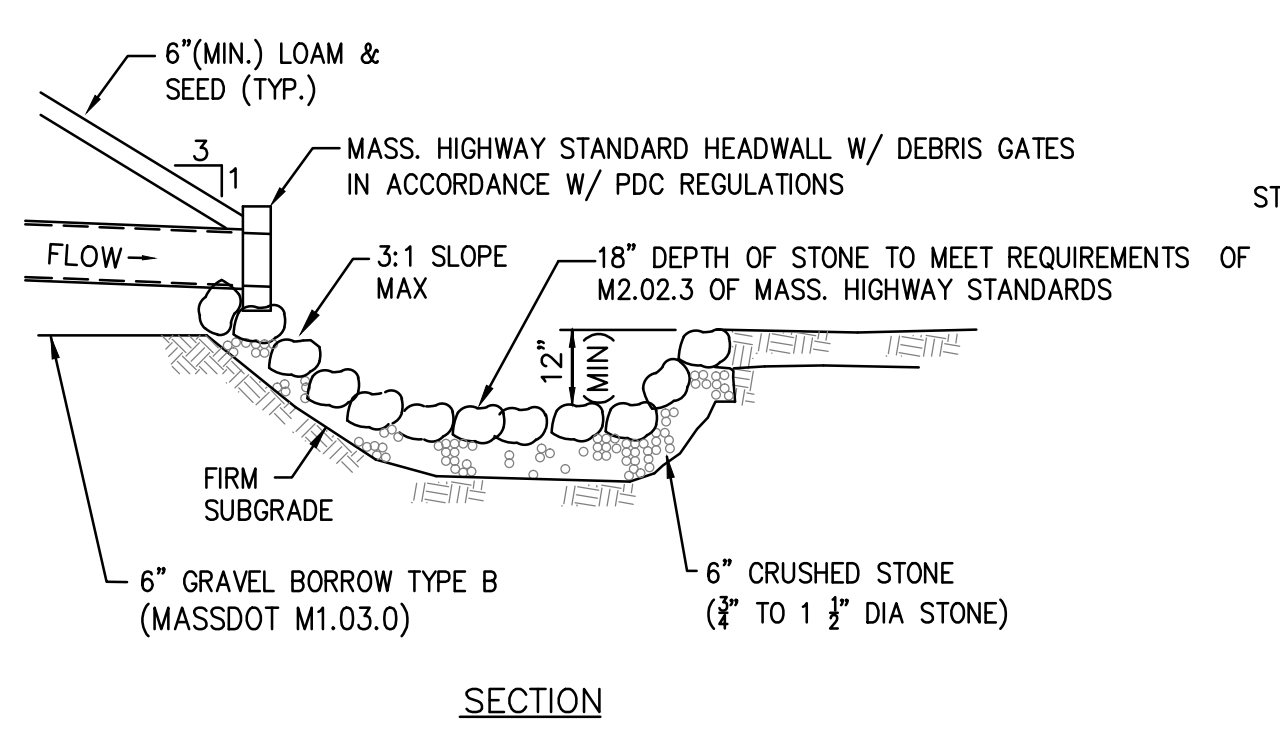

TYPICAL SEDIMENT TRAP DETAIL
SCALE: N.T.S.

DRAINAGE STRUCTURE	D=PIPE DIA.	LENGTH	WIDTH	MIN. STONE SIZE
FES-1	12"	9.0'	8.0'	8"
FES-2*	12"	-	-	-
FES-3	12"	9.0'	8.0'	8"
FES-4	12"	9.0'	8.0'	8"
FES-5	12"	9.0'	8.0'	8"
FES-6	12"	9.0'	8.0'	8"
FES-7	12"	9.0'	8.0'	8"

* OUTLET FROM DETENTION BASIN #2

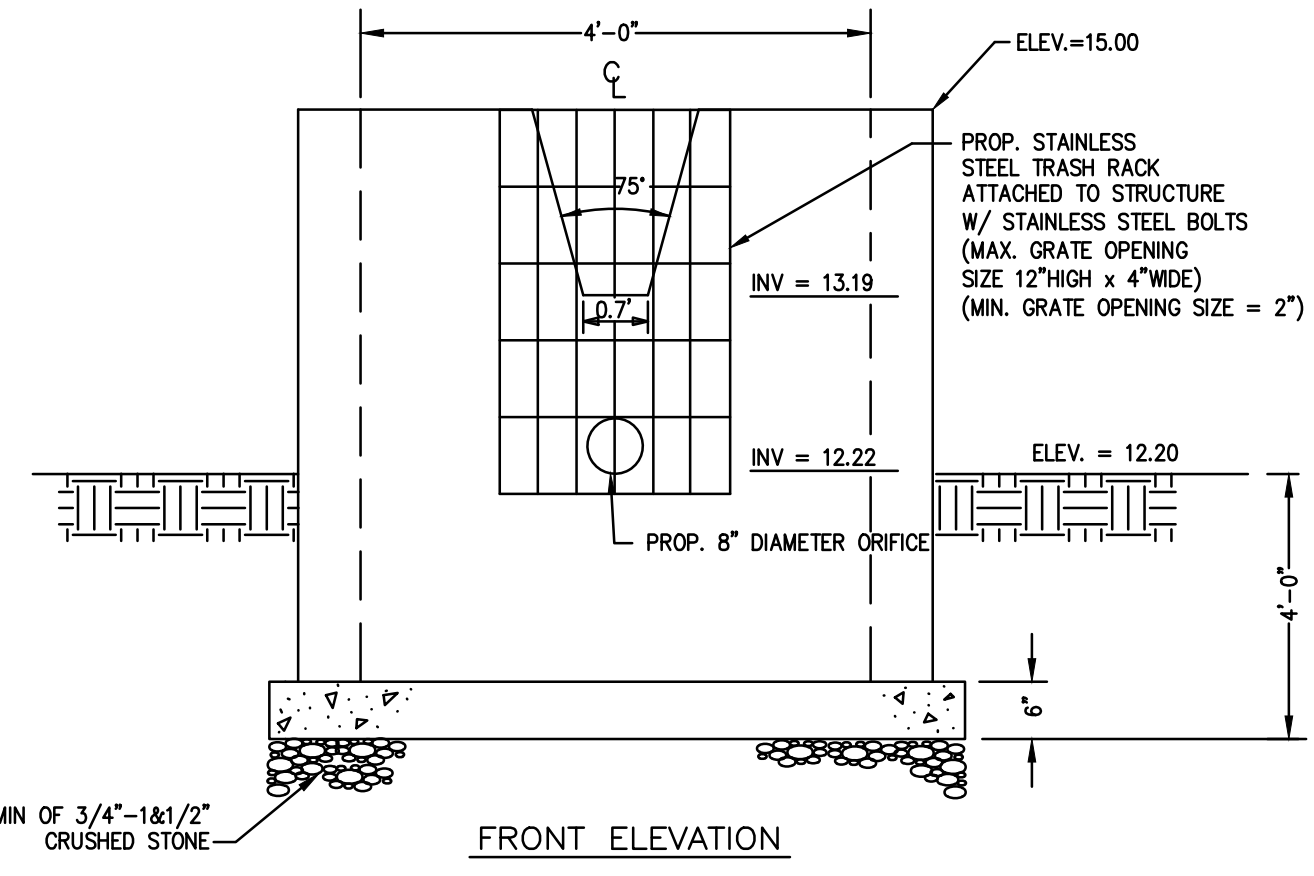
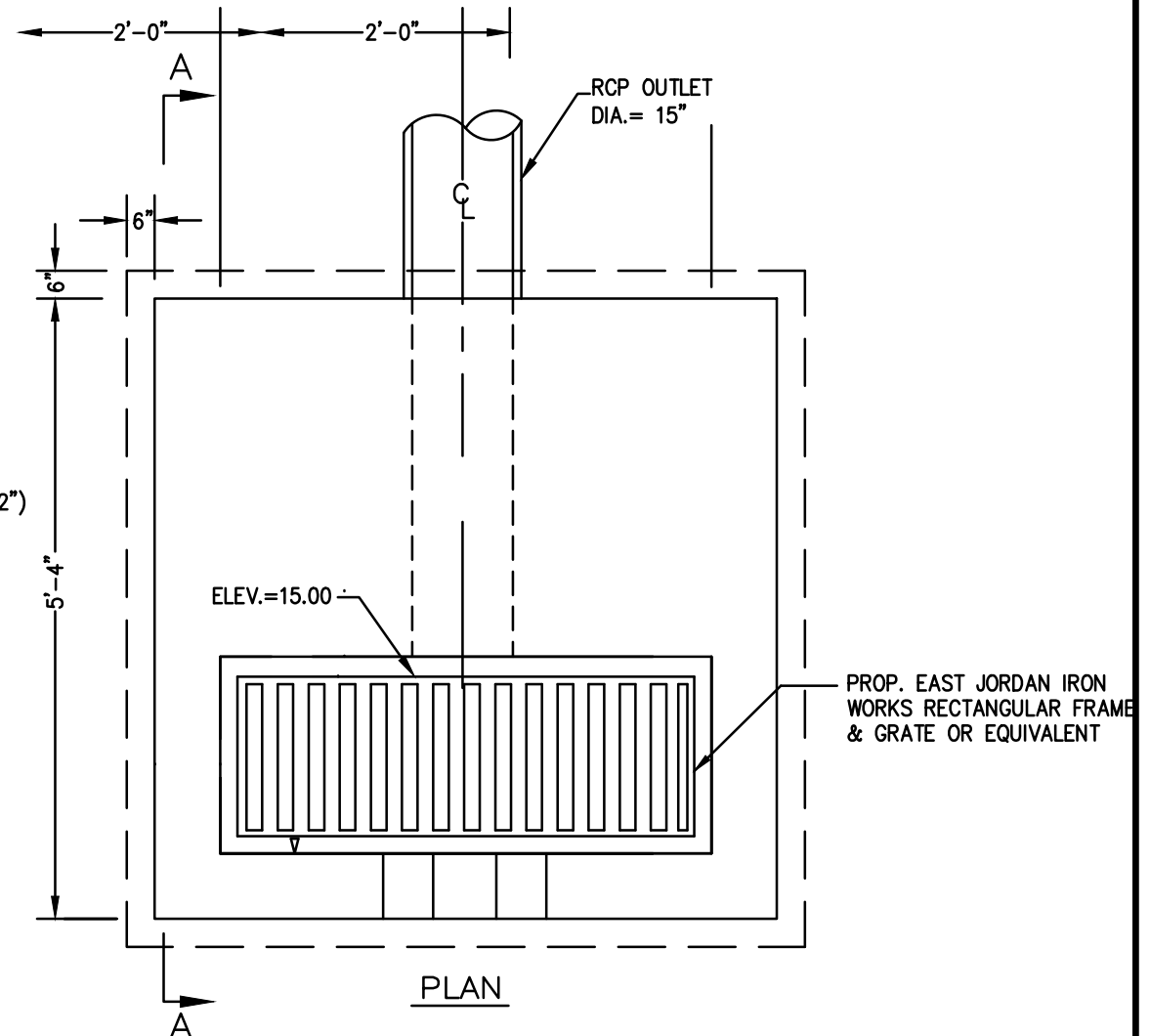
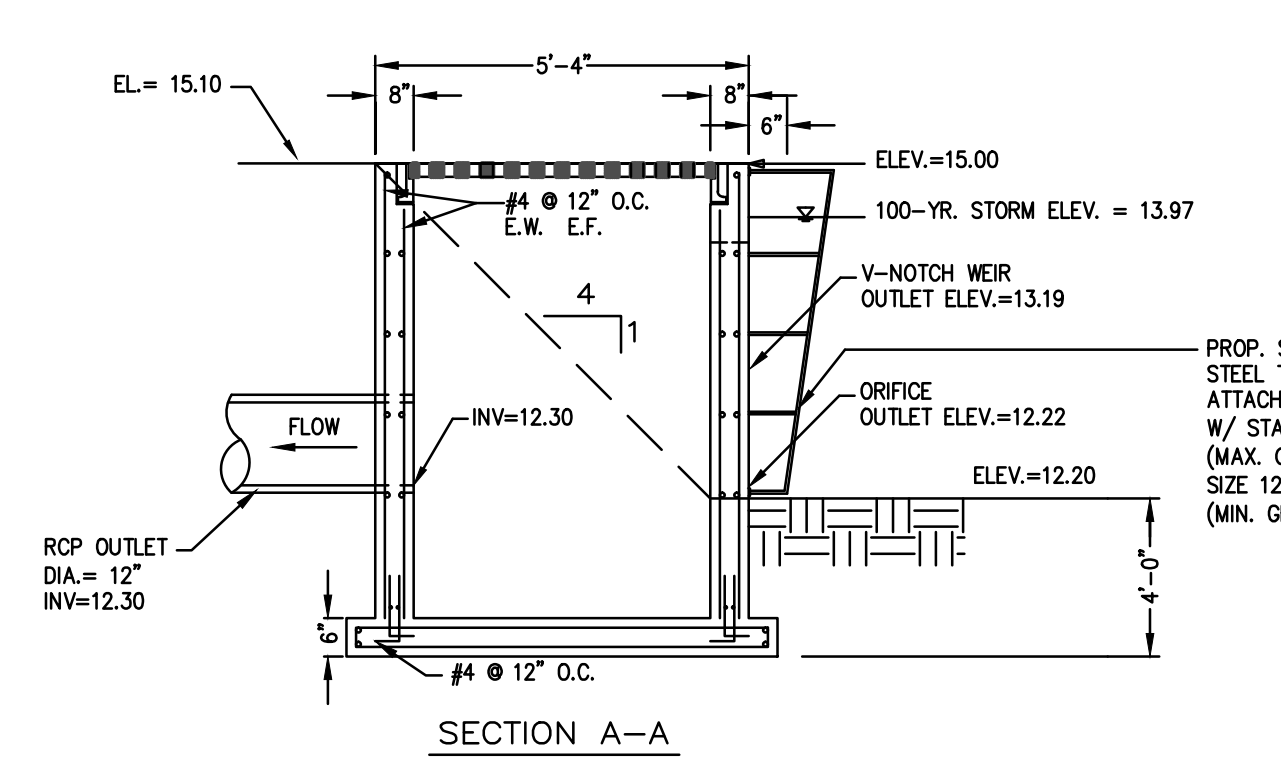
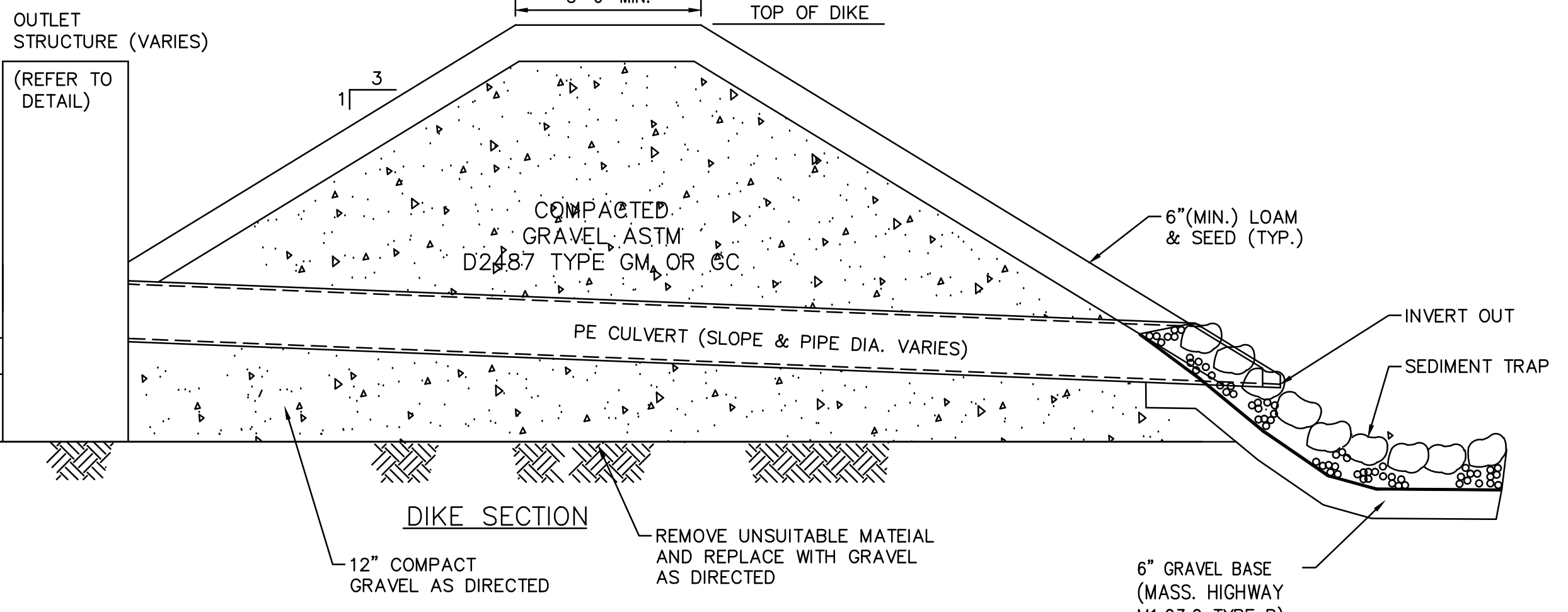

DETENTION BASIN #1 OUTLET CONTROL STRUCTURE
SCALE: N.T.S.

BY APP: []
ESS: []
BCM: []

DESCRIPTION: []
REVIEW COMMENTS: []

DATE: 4/29/20

REV: 1

MG
MCKENZIE
ENGINEERING GROUP

Assinippi Office Park
150 Longwater Drive, Suite 101
Norwell, MA 02061
P: 781.792.3900
F: 781.792.0333
www.mckeng.com

**SITE DEVELOPMENT PLANS
PROPOSED MEDICAL BUILDING
20 HENRY GRAF JR. ROAD
NEWBURYPORT, MASSACHUSETTS**

PROFESSIONAL ENGINEER:

BRADLEY C. MCKENZIE
REGISTERED PROFESSIONAL ENGINEER
No. 38917

APPLICANT:
**SPORTS MEDICINE NORTH
ORTHOPEDIC SURGERY, INC.
C/O CONSERV GROUP, INC.**
110 STATE ROAD
SAGAMORE BEACH, MASSACHUSETTS 02562

DRAWN BY: ESS
DESIGNED BY: ESS
CHECKED BY: BCM
APPROVED BY: BCM
DATE: MARCH 17, 2020
SCALE:
PROJECT NO.: 219-180
DWG. TITLE:

**CONSTRUCTION
DETAILS**

DWG. NO.: **D-4**

NOT FOR CONSTRUCTION

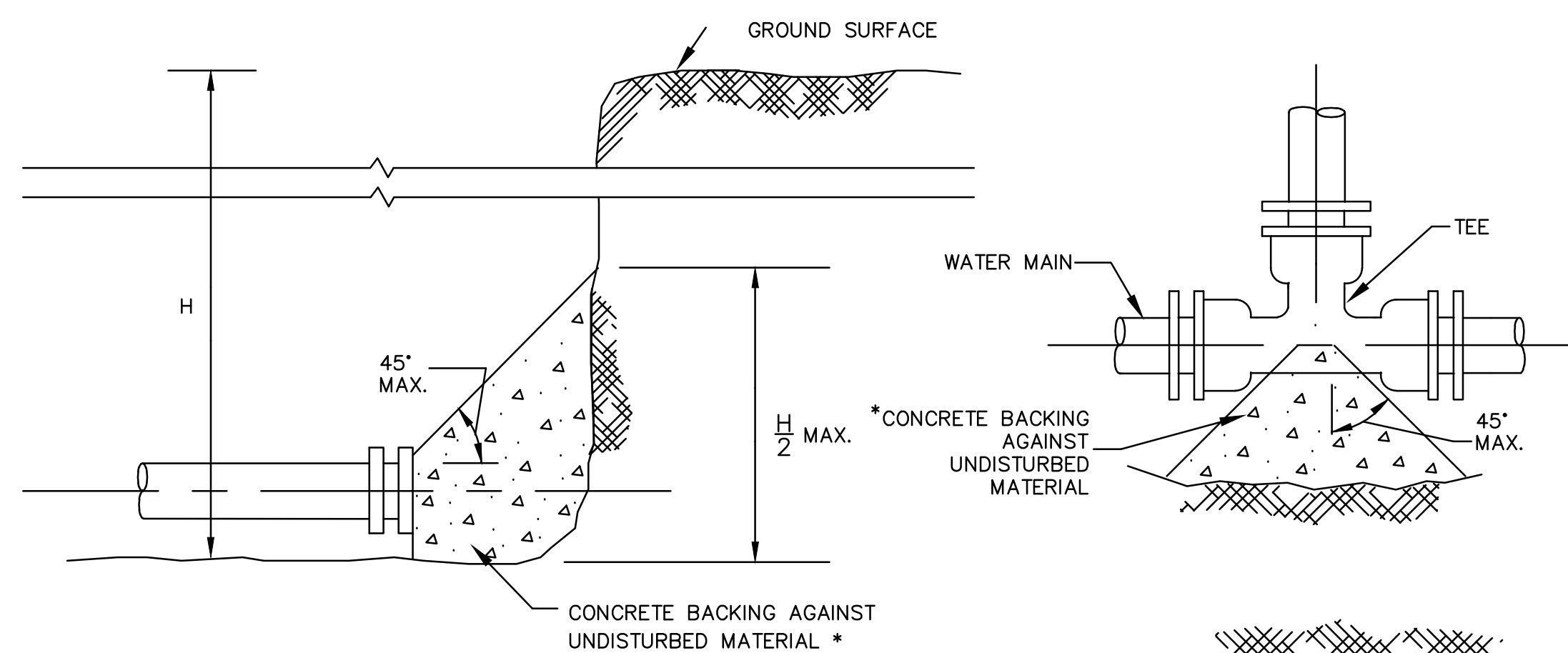

TYPICAL WATER MAIN PLUG
NOT TO SCALE

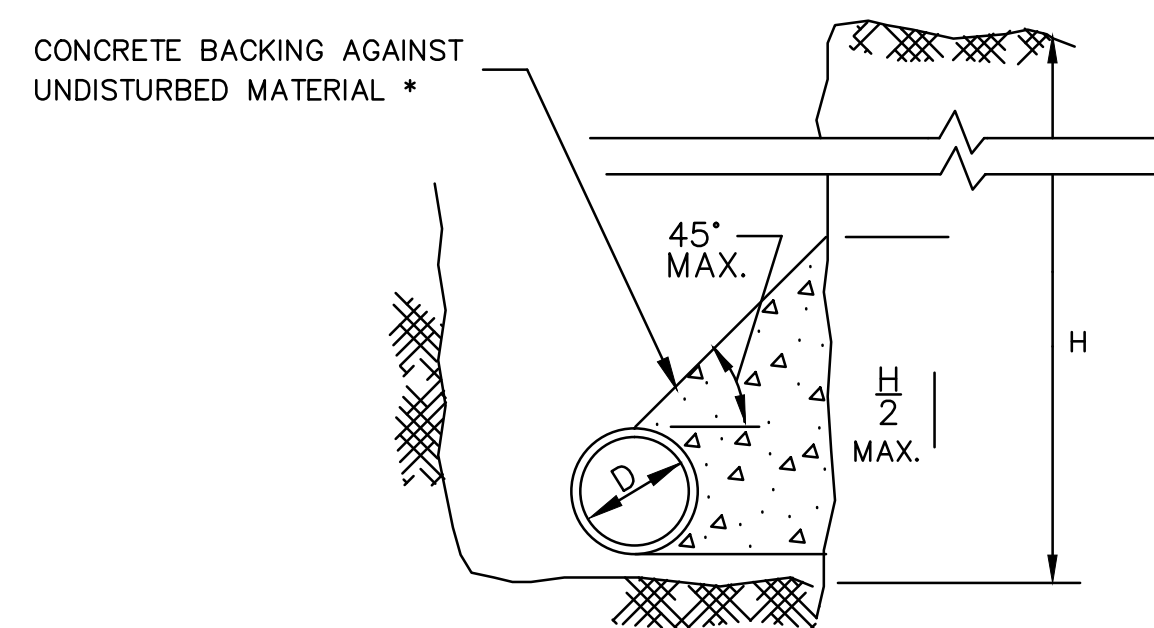

TYPICAL WATER MAIN THRUST BLOCK
SECTION DETAILS
NOT TO SCALE

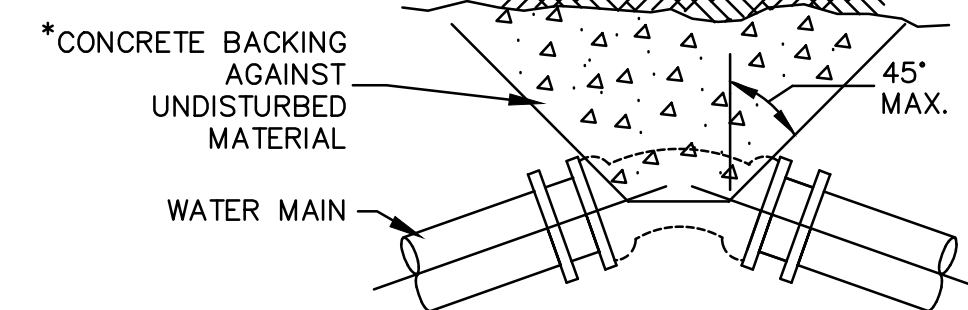

* SEE THRUST BLOCK BEARING AREAS TABLE FOR THE AREA OF CONCRETE REQUIRED.

TYPICAL WATER MAIN
THRUST BLOCK DETAILS
NOT TO SCALE

THRUST BLOCK BEARING AREAS
FOR WATER PIPE

TABLE OF BEARING AREAS IN SQ. FT. AGAINST UNDISTURBED MATERIAL FOR WATER MAIN FITTINGS*			
SIZE OF MAIN (IN.)	90° BEND	TEES AND PLUGS	45° BEND
6	4	2.5	2
8	6	4	3
12	12	9	7
16	21	16	12

* TYPE OF SOIL IS MEDIUM CLAYEY, 6 OR MORE BLOWS PER FOOT, OR LOOSE GRANULAR, 9 OR MORE BLOWS PER FOOT. SOIL CONDITIONS OTHER THAN THOSE GIVEN WILL REQUIRE LARGER BEARING AREAS.

NOTES:

- FOR FITTINGS WITH LESS THAN 45° DEFLECTION, USE BEARING AREAS FOR 45° BEND.
- BEARING AREAS BASED ON HORIZONTAL PASSIVE SOIL PRESSURE OF 2000 P.S.F. AND INTERNAL WATER PRESSURE OF 150 P.S.I.G. JOINTS SHALL NOT BE ENCASED IN CONCRETE. BEARING AREAS MAY BE DIRREGARDED FOR TRENCHES IN ROCK WHERE THE TOP OF THE ROCK FACE IS AT OR ABOVE THE CROWN OF THE PIPE. HOWEVER, CONCRETE BACKING SHALL BE PLACED BETWEEN THE PIPE AND THE ROCK FACE.
- THE CONTRACTOR SHALL SUBMIT 2 WEEKS IN ADVANCE OF PLACEMENT, WORKING DRAWINGS FOR EACH THRUST BLOCK TO THE ENGINEER FOR APPROVAL PRIOR TO INSTALLATION.
- ALL TEES, GATE VALVES, HYDRANTS AND FITTINGS SHALL BE MECHANICAL JOINTS WITH MEGA-LUGS.
- THRUST BLOCKS SHALL BE BARREL BLOCKS.

GENERAL NOTES

ALL WATER MAIN MATERIALS AND INSTALLATION SHALL BE IN ACCORDANCE WITH THE NEWBURYPORT WATER DEPARTMENT RULES AND REGULATIONS.

- IF SHEETING IS USED, IT SHALL BE CUT OFF NO MORE THAN 12" ABOVE TOP OF PIPE.
- ALL PIPES SHALL BE PRESSURE TESTED AT 200 PSI WORKING PRESSURE FOR A MINIMUM DURATION OF TWO HOUR.
- WATER SYSTEM IS TO BE DISINFECTED TO 50 P.P.M. AVAILABLE CHLORINE AND AFTER 24 HOURS TO 25 P.P.M. OR AS REQUIRED BY NEWBURYPORT WATER SUPERINTENDENT/ENGINEER.
- WATER PIPE IS TO BE CEMENT LINED DUCTILE IRON "TYTON" OR EQUAL TYPE JOINT, CONFORMING TO A.N.S.I./A.W.W.A. C150/A21.50, CLASS 52, AS APPROVED BY THE NEWBURYPORT WATER SUPERINTENDENT/ENGINEER.
- ALL PIPING SHALL BE INSTALLED AND TESTED IN ACCORDANCE WITH A.W.W.A. STANDARDS PRIOR TO PAVING IF PAVING ABOVE TRENCH IS REQUIRED.
- BACKFILL IS TO BE COMPACTED TO 90% MAXIMUM DRY DENSITY BY AASHTO T-180 D.
- ALL WATER PIPE SHALL BE LAID WITH A MINIMUM OF 5 FEET OF COVER OF APPROVED MATERIALS.
- ALL HYDRANT LOCATIONS ARE TO BE APPROVED BY FIRE DEPARTMENT.
- RESULTS FROM PRESSURE TESTING AND DISINFECTION SHALL BE FURNISHED TO THE DIRECTOR OF PUBLIC WORKS FOR APPROVAL PRIOR TO WATER BEING TURNED ON.
- ALL WORK SHALL BE IN CONFORMANCE WITH NEWBURYPORT WATER DEPARTMENT STANDARDS.
- ALL PERMITS REQUIRED FOR STREET OPENINGS AND WATER MAIN TAPPING MUST BE OBTAINED.
- NO WATER WILL BE TURNED ON IN THE PROJECT WITHOUT WATER DEPARTMENT APPROVAL.

REV	DATE	DESCRIPTION	BY	APP
1	4/29/20	REVIEW COMMENTS	ESS	BCM

MEG
MCKENZIE
ENGINEERING GROUP
Assinippi Office Park
150 Longwater Drive, Suite 101
Norwell, MA 02061
P: 781.792.3900
F: 781.792.0333
www.mckeng.com

**SITE DEVELOPMENT PLANS
PROPOSED MEDICAL BUILDING
20 HENRY GRAF JR. ROAD
NEWBURYPORT, MASSACHUSETTS**

PROFESSIONAL ENGINEER:



APPLICANT:
SPORTS MEDICINE NORTH
ORTHOPEDIC SURGERY, INC.
C/O CONSERV GROUP, INC.
110 STATE ROAD
SAGAMORE BEACH, MASSACHUSETTS 02562

DRAWN BY: ESS
DESIGNED BY: ESS
CHECKED BY: BCM
APPROVED BY: BCM
DATE: MARCH 17, 2020
SCALE:
PROJECT NO.: 219-180
DWG. TITLE:

**CONSTRUCTION
DETAILS**

DWG. NO:
D-5

NOT FOR CONSTRUCTION

EROSION AND SEDIMENTATION CONTROL

- WIDELY ACCEPTED PRACTICES FOR REDUCING EROSION AND SEDIMENTATION WILL BE EMPLOYED IN THE DEVELOPMENT OF THIS SITE.
- THE DEVELOPMENT OF THE SITE HAS BEEN PLANNED TO ENHANCE THE EXISTING TOPOGRAPHY AND VEGETATIVE COVER. ALL NATURAL DRAINAGE PATTERNS OF THE SITE HAVE BEEN MAINTAINED.
- STEEP SLOPES, WHERE POSSIBLE, WILL NOT BE DISTURBED.
- NATURAL WATERWAYS WILL BE PRESERVED AND PROTECTED, AND EXISTING VEGETATION WILL BE RETAINED AND PROTECTED TO THE EXTENT POSSIBLE.
- THE ROADWAY CONFORMS TO EXISTING LAND CONTOURS WHERE PRACTICAL.
- THE CONTRACTOR SHALL MINIMIZE THE AREA OF DISTURBED LAND TO THE EXTENT FEASIBLE.
- SEDIMENT CONTROL MEASURES WILL BE APPLIED TO CONTROL ANY SEDIMENTS THAT MAY BE PRODUCED AS A RESULT OF SITE CONSTRUCTION ACTIVITIES. EROSION AND DEPOSITION OF SEDIMENT WILL BE CLOSELY MONITORED DURING CONSTRUCTION.
- TEMPORARY EROSION CONTROL MEASURES WILL INCLUDE, BUT NOT BE LIMITED TO, HAY BALE CHECK DAMS, SEDIMENT FOREBAYS, STABILIZED CONSTRUCTION ENTRANCES, FILTER FABRIC SILT FENCES, SEEDING AND MULCHING, AND SEEDED FILTER STRIPS.
- TOPSOIL STRIPPED FROM CUT AND FILL AREAS WILL BE STOCKPILED FOR LOAMING AND SEEDING AT LATER CONSTRUCTION STAGES. THE STOCKPILES SHALL BE LOCATED SO AS TO ACT AS TEMPORARY DIVERSIONS, GENERALLY ON THE UPHILL SLOPE.
- ALL CUT AREAS LOCATED AT TOES OF SLOPES AND DITCHES THAT HAVE GRADES EXCEEDING 5% SHALL BE STABILIZED WITH RIP-RAP. THE RIP-RAP SHALL CONSIST OF 50% STONES GREATER THAN 6" IN SIZE. SWALES SHALL BE 6" IN DEPTH AND APPROXIMATELY 5' IN WIDTH. ALL SLOPES WILL BE BLENDED INTO THE EXISTING TOPOGRAPHY TO MINIMIZE IMPACT.
- SITE DEVELOPMENT WILL NOT COMMENCE UNTIL ALL TEMPORARY EROSION CONTROL MEASURES ARE IN PLACE. THESE MEASURES SHALL BE EMPLOYED UNTIL FINAL PAVING AND ADEQUATE VEGETATION HAS BEEN ESTABLISHED.
- REFER TO CONSTRUCTION PHASE BEST MANAGEMENT PRACTICES AS SPECIFIED IN "BEST MANAGEMENT PRACTICES OPERATION AND MAINTENANCE PLAN" PREPARED BY MCKENZIE ENGINEERING GROUP, INC. FOR STRUCTURAL STABILIZATION AND DUST CONTROL EROSION AND SEDIMENTATION CONTROL MEASURES.
- STABILIZATION PRACTICES UTILIZED FOR THE PROJECT WILL INCLUDE TEMPORARY SEEDING, GEOTEXTILES (JUTE MESH), MULCHING, AND PERMANENT SEEDING.

CONSTRUCTION PHASE BMP OPERATION & MAINTENANCE:

STRUCTURAL PRACTICES UTILIZED FOR THE PROJECT WILL INCLUDE SILT SOCK EROSION CONTROL BARRIERS, STABILIZED CONSTRUCTION ENTRANCES, TEMPORARY DIVERSION SWALES WITH CHECK DAMS, TEMPORARY SEDIMENT BASINS, AND INLET PROTECTION.

STABILIZATION PRACTICES UTILIZED FOR THE PROJECT WILL INCLUDE TEMPORARY SEEDING, GEOTEXTILES (JUTE MESH), MULCHING, AND PERMANENT SEEDING.

OPERATOR PERSONNEL AND/OR ITS CONSULTANTS MUST INSPECT THE CONSTRUCTION SITE AT LEAST ONCE EVERY 7 CALENDAR DAYS AND WITHIN 24 HOURS OF A STORM EVENT OF 1/2 INCH OR GREATER. THE INSPECTOR SHOULD REVIEW THE EROSION AND SEDIMENT CONTROLS WITH RESPECT TO THE FOLLOWING:

- WHETHER OR NOT THE BMP WAS INSTALLED/PERFORMED CORRECTLY.
- WHETHER OR NOT THERE HAS BEEN DAMAGE TO THE BMP SINCE IT WAS INSTALLED OR PERFORMED.
- WHAT SHOULD BE DONE TO CORRECT ANY PROBLEMS WITH THE BMP.

THE INSPECTOR SHALL COMPLETE THE INSPECTION SCHEDULE AND EVALUATION CHECKLIST FOR FINDINGS AND SHOULD REQUEST THE REQUIRED MAINTENANCE OR REPAIR. THE CHECKLIST IS PROVIDED WITHIN THE OPERATION AND MAINTENANCE PLAN.

THE TEMPORARY SEDIMENT BASINS SHALL BE INSPECTED AND CLEANED IF REQUIRED PRIOR TO ANY PREDICTED LARGE STORM EVENT.

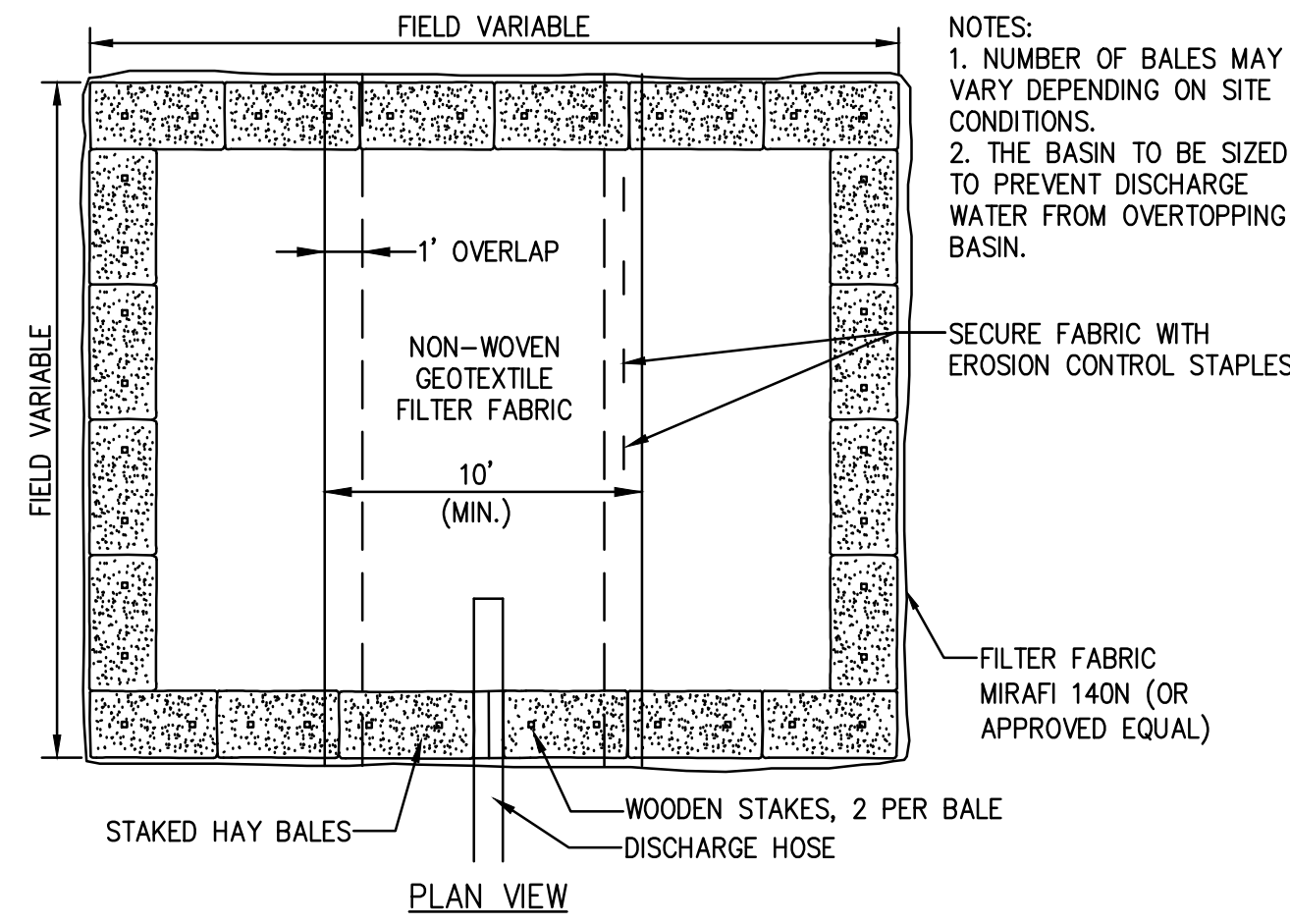

- NOTES:
- NUMBER OF BALES MAY VARY DEPENDING ON SITE CONDITIONS.
 - THE BASIN TO BE SIZED TO PREVENT DISCHARGE WATER FROM OVERTOPPING BASIN.

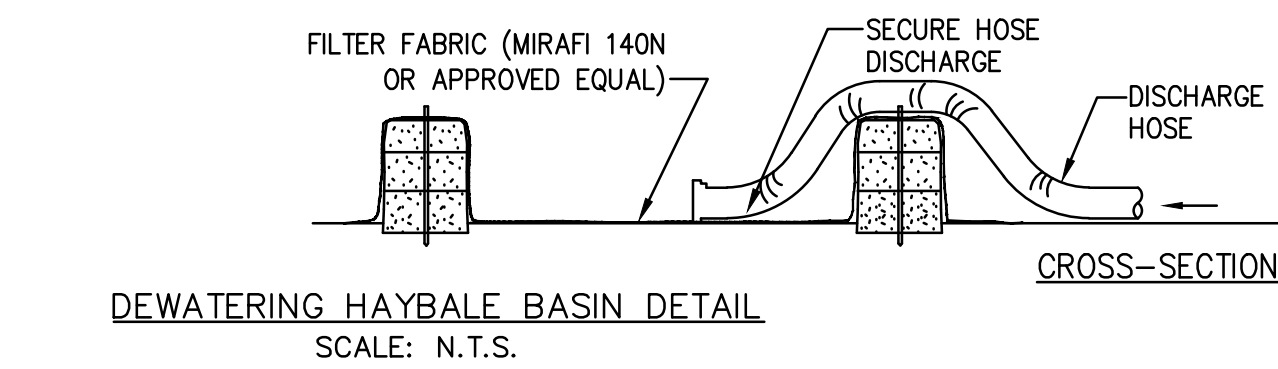

- NOTE:
- TO BE USED IN LOCATIONS WHERE EXIST. GROUND SLOPES IN TOWARD THE TOE OF THE EMBANKMENT. OR IN WIDE DITCHES.

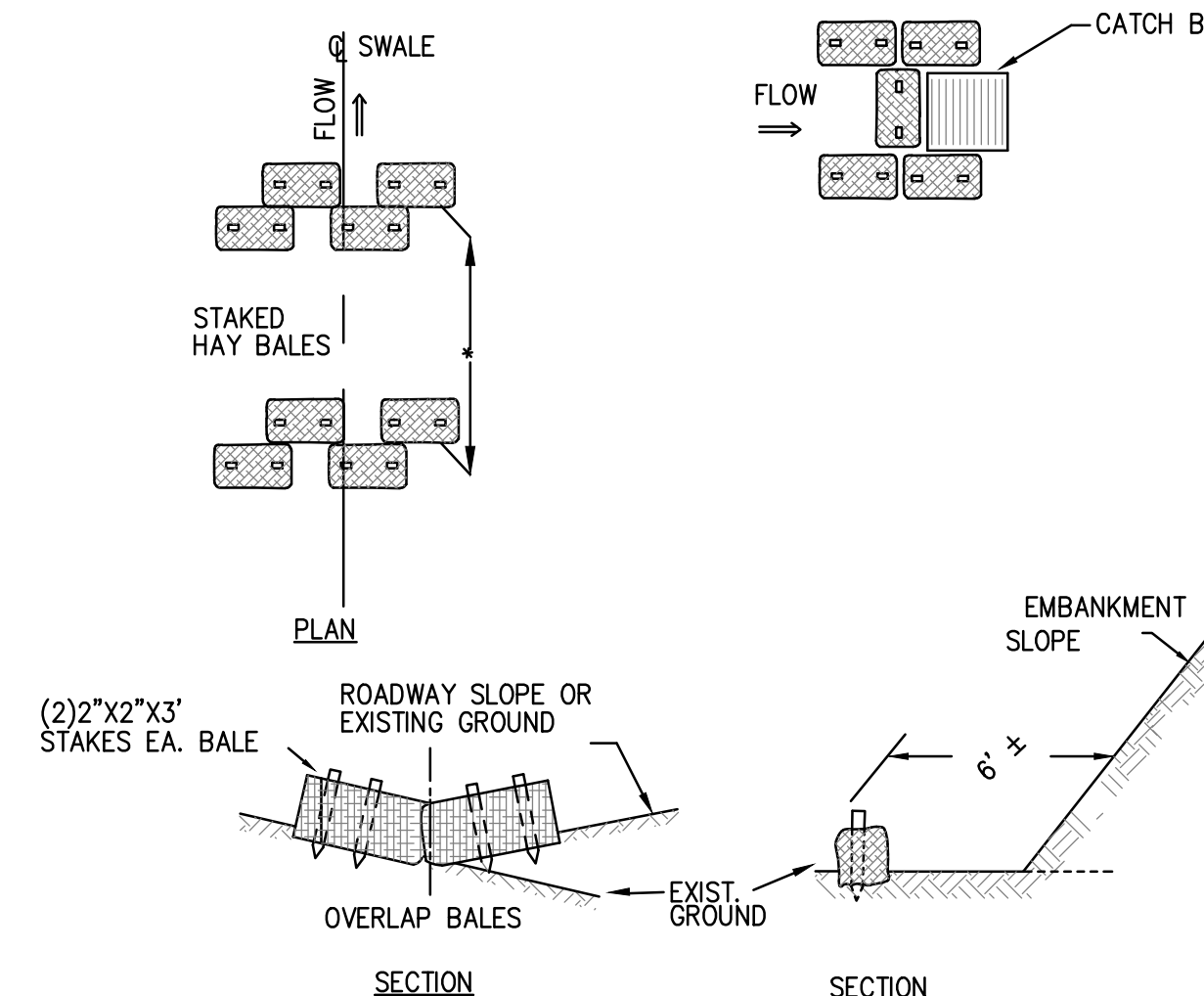

- NOTE:
- TO BE USED AROUND CATCH BASINS.

- NOTE:
- TO BE USED IN LOCATIONS WHERE EXIST. GROUND SLOPES IN TOWARD THE TOE OF THE EMBANKMENT. OR IN NARROW DITCHES.

- NOTE:
- TO BE USED AT BOTTOM OF FILL SLOPE WHERE HEAVY FLOW MAY BE ANTICIPATED.

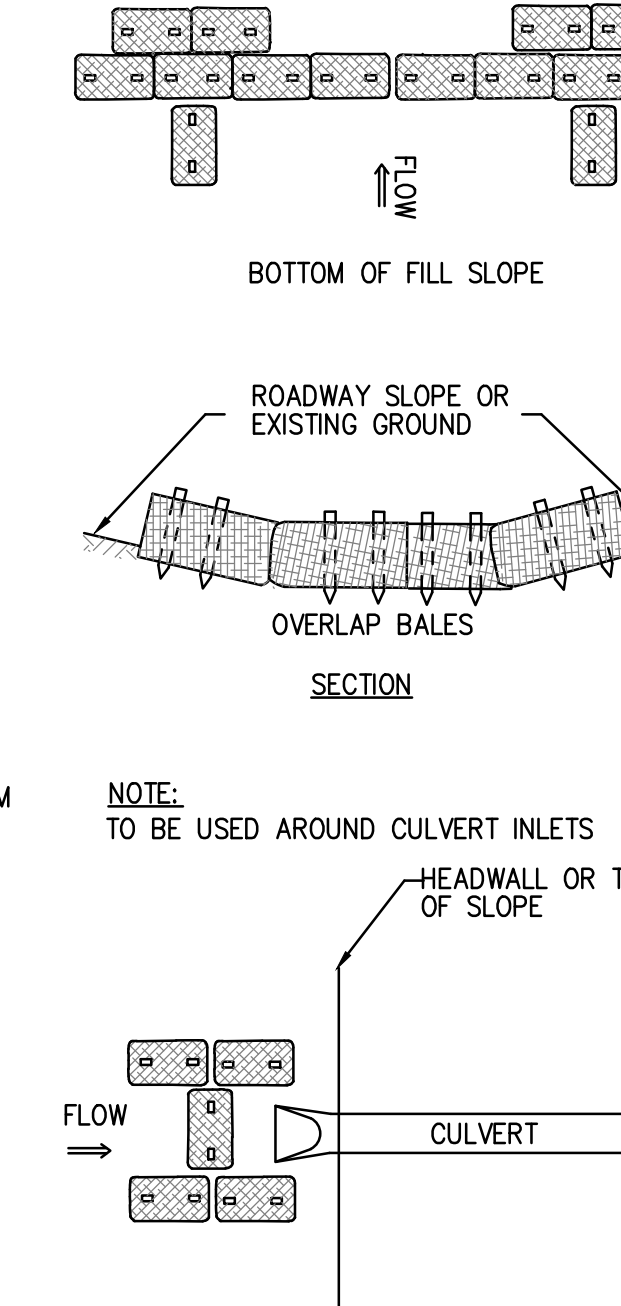

- NOTE:
- TO BE USED WHERE EXIST. GROUND SLOPES AWAY FROM THE TOE OF THE EMBANKMENT.

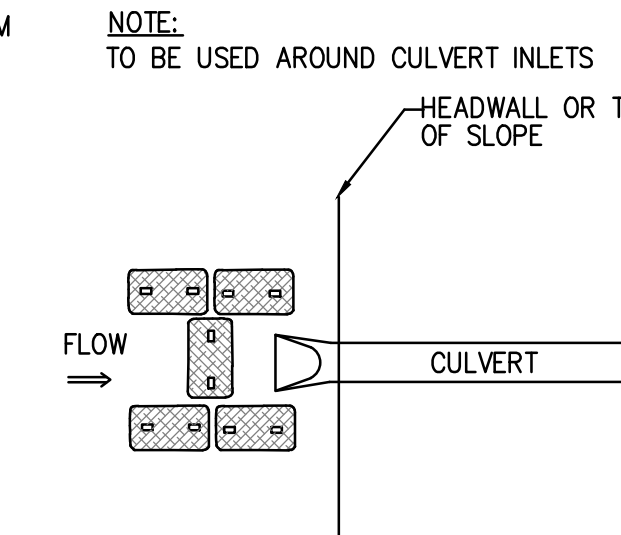

(SCE) CONSTRUCTION SPECIFICATIONS:

- STONE FOR A STABILIZATION CONSTRUCTION ENTRANCE SHALL BE 1 TO 2 INCH STONE, RECLAIMED STONE.
- THE LENGTH OF THE STABILIZED ENTRANCE SHALL NOT BE LESS THAN 50 FEET, EXCEPT FOR A SINGLE RESIDENTIAL LOT A 30 FOOT MINIMUM LENGTH WOULD APPLY.
- THE THICKNESS OF THE STONE FOR THE STABILIZED ENTRANCE SHALL NOT BE LESS THAN 6 INCHES.
- THE WIDTH OF THE ENTRANCE SHALL NOT BE LESS THAN A FULL WIDTH OF THE ENTRANCE WHERE INGRESS OR EGRESS OCCURS OR 10 FEET, WHICH EVER IS GREATER.
- GEOTEXTILE FILTER CLOTH SHALL BE PLACED OVER THE ENTIRE AREA PRIOR TO PLACING THE STONE.
- ALL SURFACE WATER THAT IS FLOWING TO OR DEVERTED TOWARDS THE CONSTRUCTION ENTRANCE SHALL BE PIPED BENEATH THE ENTRANCE. IF PIPING IS IMPRACTICAL, A BERM WITH 5:1 SLOPES THAT CAN BE CROSSED BY VEHICLES MAY BE SUBSTITUTED FOR THE PIPE.
- THE ENTRANCE SHALL BE MAINTAINED IN A CONDITION THAT WILL PREVENT TRACKING OR FLOWING OF SEDIMENT ONTO PUBLIC RIGHTS-OF-WAY. THIS MAY REQUIRE PERIODIC TOPDRESSING WITH ADDITIONAL STONE AS CONDITIONS DEMAND AND REPAIR AND/OR CLEANOUT OF ANY MEASURES USED TO TRAP SEDIMENT. SEDIMENT SPILLED, WASHED, OR TRACKED ONTO PUBLIC RIGHTS-OF-WAY MUST BE REMOVED PROMPTLY.

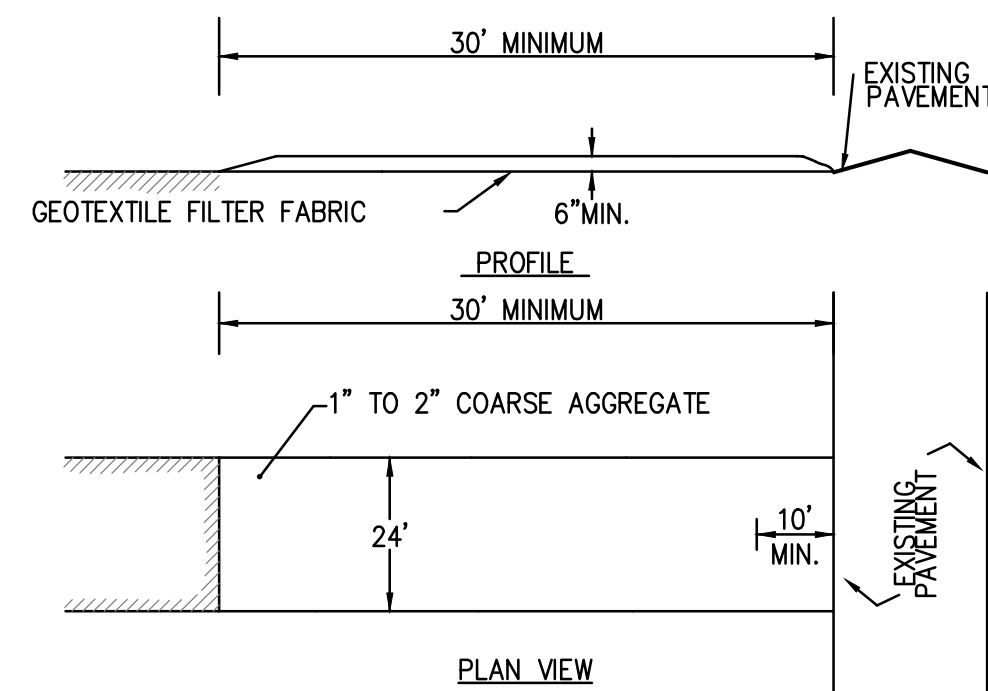

STABILIZED CONSTRUCTION ENTRANCE (SCE) DETAIL
SCALE: N.T.S.

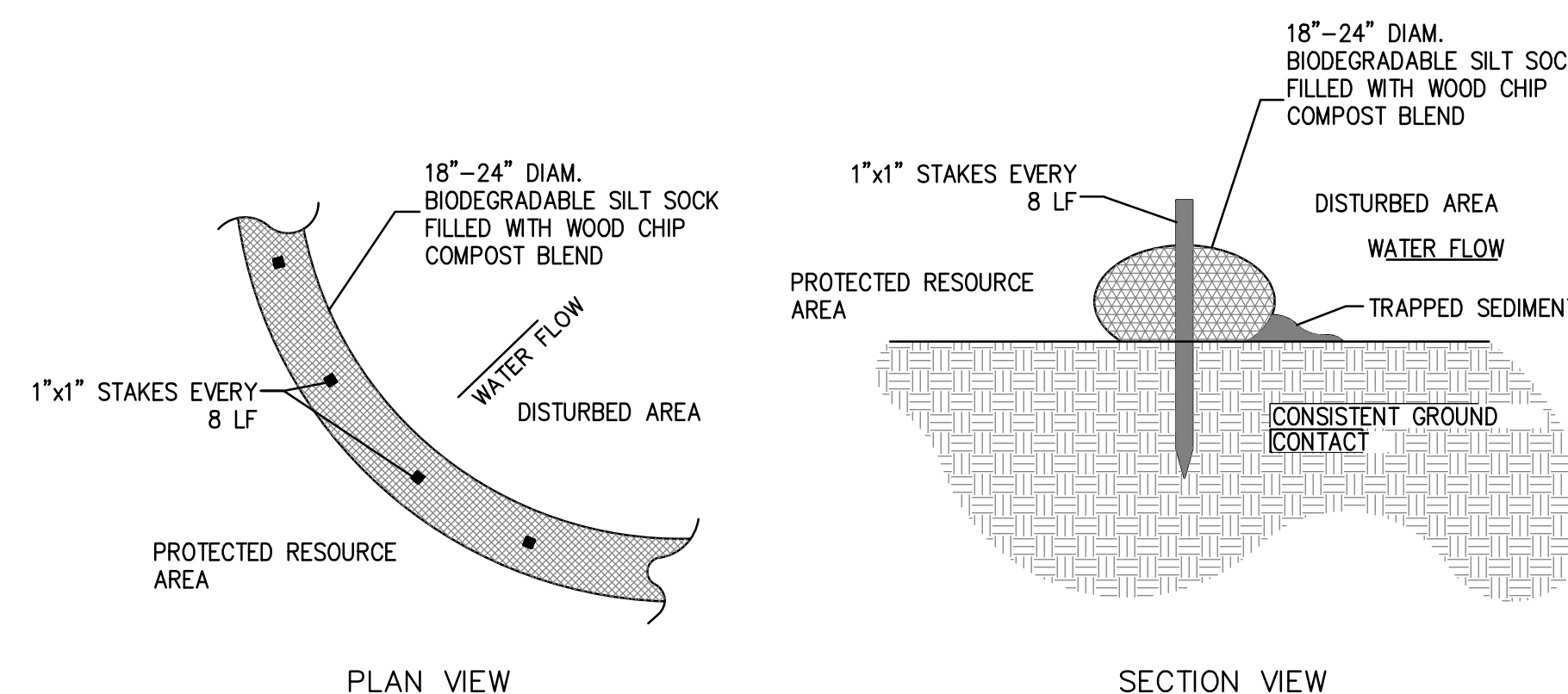

- CONSTRUCTION NOTES:
- SILT SOCKS SHALL BE PLACED IN A ROW WITH ENDS TIGHTLY ABUTTING OR LAPPING THE ADJACENT SECTIONS.
 - SILT SOCKS SHALL BE SECURELY ANCHORED IN PLACE BY STAKES OR RE-BARS DRIVEN EVERY 8 LF.
 - INSPECTION SHALL BE FREQUENT, AND REPAIR OR REPLACEMENT SHALL BE MADE PROMPTLY AS REQUIRED.
 - SILT SOCKS SHALL BE REMOVED WHEN THEY HAVE SERVED THEIR USEFULNESS, SO AS NOT TO BLOCK OR IMPEDE STORM FLOW OR DRAINAGE.

SILT SOCK DETAIL
SCALE: N.T.S.

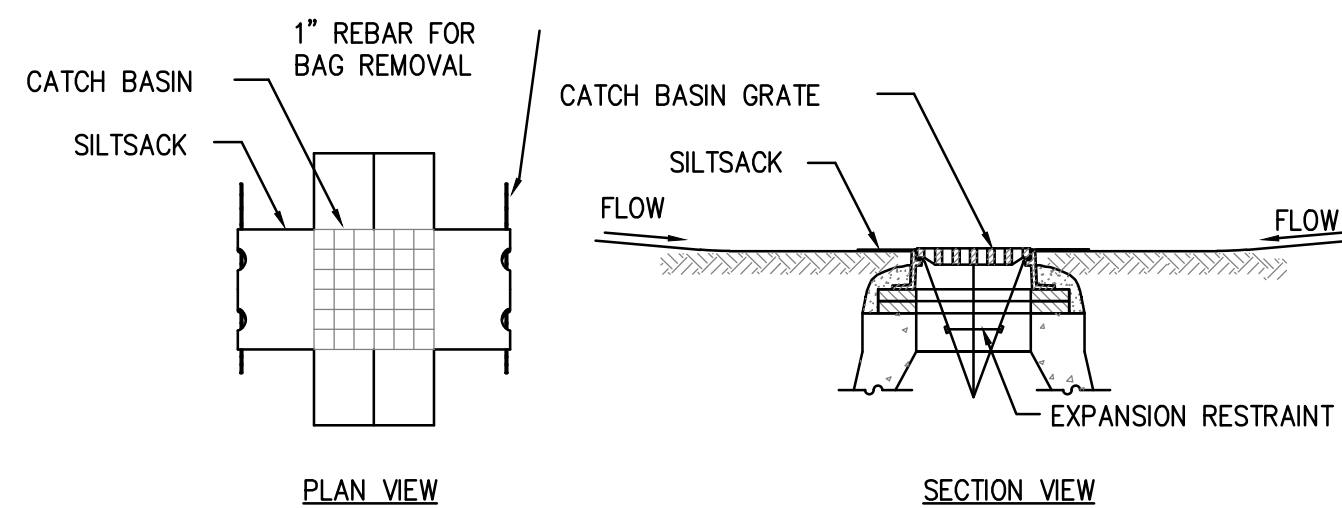

SILT SACK SEDIMENT TRAP CONSTRUCTION NOTES:

- INSTALL SILT SACK IN ALL CATCH BASINS WHERE INDICATED ON THE PLAN BEFORE COMMENCING WORK OR IN PAVED AREAS AFTER BINDER COURSE IS PLACED AND HAY BALES HAVE BEEN REMOVED.
- GRATE TO BE PLACED OVER SILT SACK.
- SILT SACK SHALL BE INSPECTED PERIODICALLY AND AFTER ALL STORM EVENTS AND CLEANING OR REPLACEMENT SHALL BE PERFORMED PROMPTLY AS NEEDED. MAINTAIN UNTIL UPSTREAM AREAS HAVE BEEN PERMANENTLY STABILIZED.

SILT SACK SEDIMENT TRAP
SCALE: N.T.S.

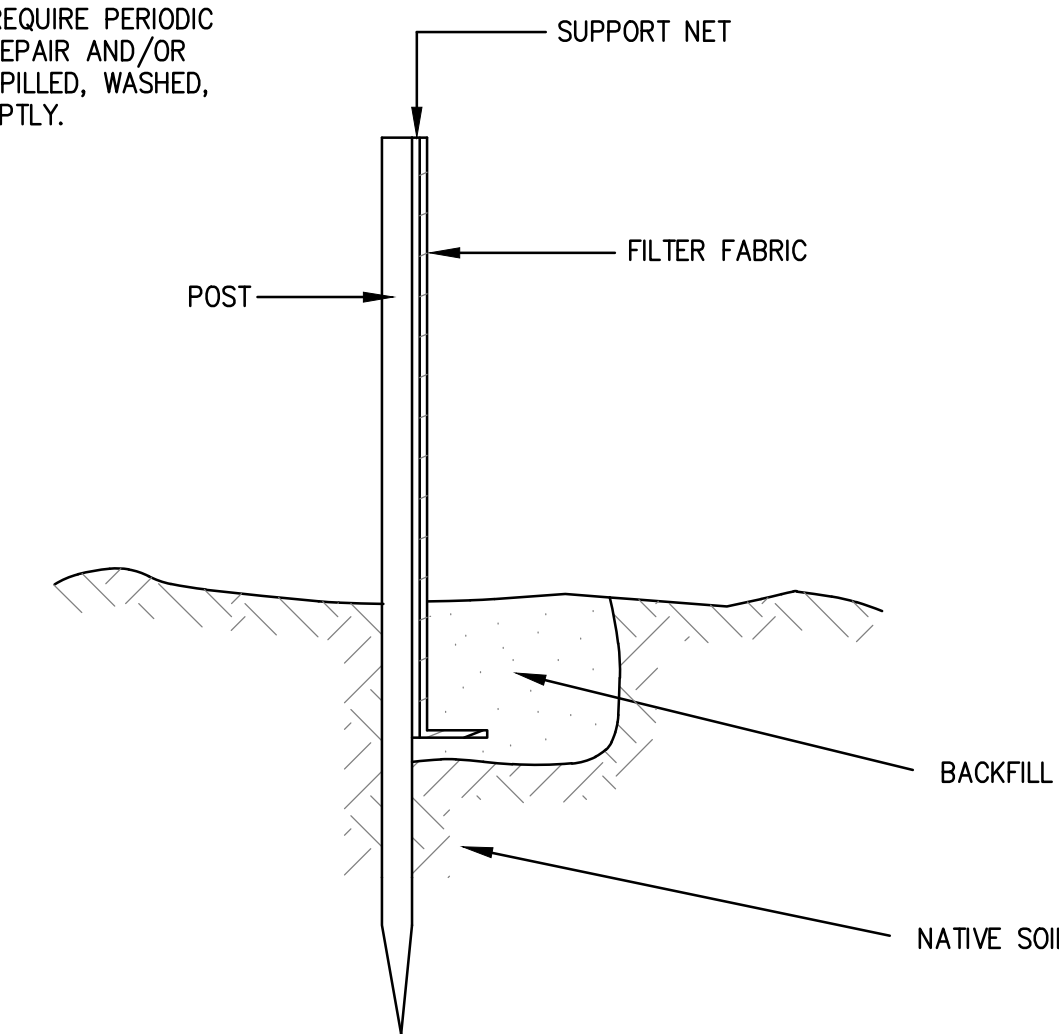

- CONSTRUCTION NOTES:
- WOVEN WIRE FENCE TO BE FASTENED SECURELY TO FENCE POSTS WITH WIRE TIES OR STAPLES.
 - FILTER CLOTH TO BE FASTENED SECURELY TO WOVEN WIRE FENCE WITH TIES SPACED EVERY 24" AT TOP AND MID SECTION.
 - WHEN TWO SECTIONS OF FILTER CLOTH ADJOIN EACH OTHER, THEY SHALL BE OVERLAPPED BY 6 INCHES AND FOLDED.
 - MAINTENANCE SHALL BE PERFORMED AS NEEDED AND MATERIAL REMOVED WHEN "BULGES" DEVELOP IN THE SILT FENCE.

SILTATION FENCE
SCALE: N.T.S.

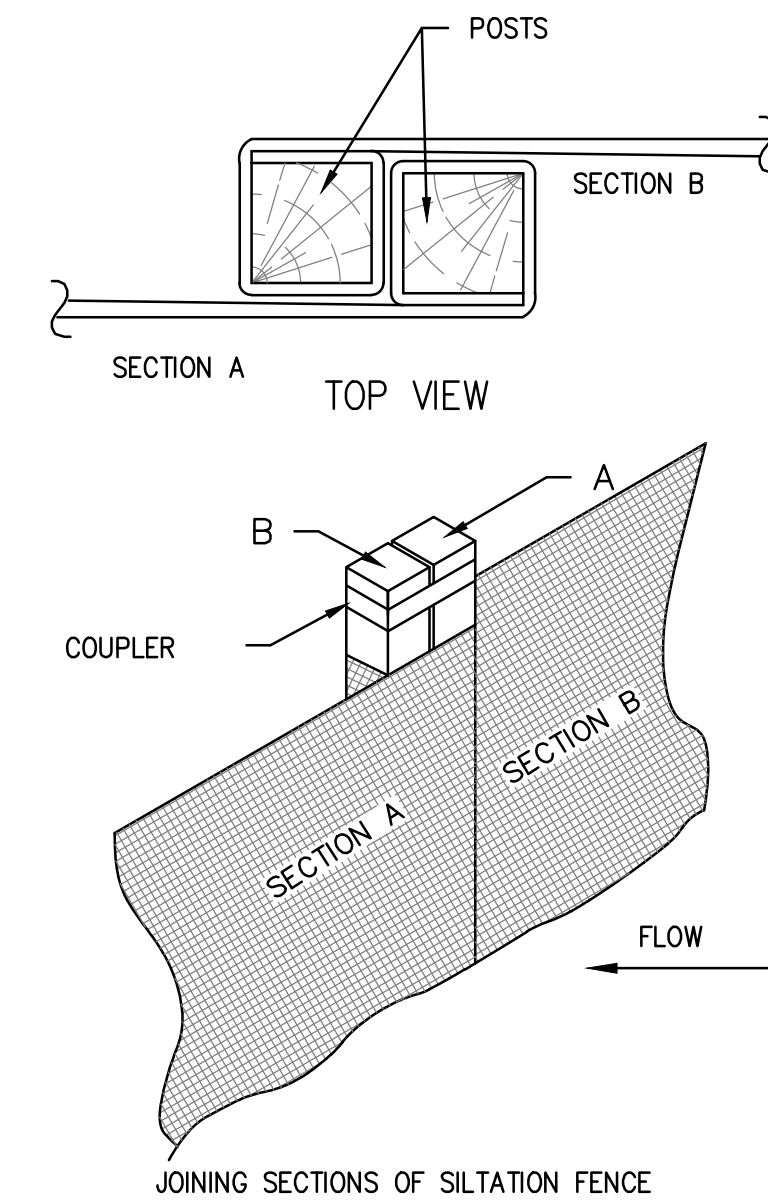

- NOTES:
- INSTALL SILT SACK IN ALL CATCH BASINS WHERE INDICATED ON THE PLAN BEFORE COMMENCING WORK OR IN PAVED AREAS AFTER BINDER COURSE IS PLACED AND HAY BALES HAVE BEEN REMOVED.
 - GRATE TO BE PLACED OVER SILT SACK.
 - SILT SACK SHALL BE INSPECTED PERIODICALLY AND AFTER ALL STORM EVENTS AND CLEANING OR REPLACEMENT SHALL BE PERFORMED PROMPTLY AS NEEDED. MAINTAIN UNTIL UPSTREAM AREAS HAVE BEEN PERMANENTLY STABILIZED.

© MCKENZIE ENGINEERING GROUP, INC.

REV	DATE	DESCRIPTION	BY	APP
1	4/29/20	REVIEW COMMENTS	ESS	BCM



SITE DEVELOPMENT PLANS PROPOSED MEDICAL BUILDING 20 HENRY GRAF JR. ROAD NEWBURYPORT, MASSACHUSETTS

PROFESSIONAL ENGINEER:



APPLICANT:
SPORTS MEDICINE NORTH
ORTHOPEDIC SURGERY, INC.
C/O CONSERV GROUP, INC.
110 STATE ROAD
SAGAMORE BEACH, MASSACHUSETTS 02562

DRAWN BY: ESS
DESIGNED BY: ESS
CHECKED BY: BCM
APPROVED BY: BCM
DATE: MARCH 17, 2020
SCALE:
PROJECT NO.: 219-180
DWG. TITLE:

CONSTRUCTION
DETAILS

DWG. NO.:
D-6

NOT FOR CONSTRUCTION