

PRESERVATION RESTRICTION AGREEMENT

Between

Newburyport Landing LLC
and the



SO.ESSEX #72 Bk:36493 Pg:037
01/26/2018 09:18 AM AGRT Pg 1/47
eRecorded

CITY OF NEWBURYPORT, MASSACHUSETTS

BY AND THROUGH THE NEWBURYPORT HISTORICAL COMMISSION

THIS PRESERVATION RESTRICTION is made this 30th day of OCTOBER 2017 (this "Restriction") by and between Newburyport Landing LLC c/o First Republic Corporation of America, located at 40 East 69th Street, New York, New York, 10021 ("Grantor"), and the CITY OF NEWBURYPORT ("Grantee"), a municipality duly organized under the laws of the Commonwealth of Massachusetts and located in Essex County, Massachusetts, to be managed and enforced by its agent, the NEWBURYPORT HISTORICAL COMMISSION (the "Commission"), located at 60 Pleasant Street, Newburyport, Massachusetts, 01950.

WHEREAS, the Grantor is owner in fee simple of certain real property located at 262 Merrimac Street, Newburyport, Massachusetts, being a portion of the same property conveyed to Newburyport Landing LLC in a deed recorded with the Essex South Registry of Deeds on September 26, 2016 in Book 35292 and Page 19, which portion is Lot 2 as described therein and in Exhibit A, attached hereto and incorporated herein by reference (the "Property"), and as shown on a plan entitled "Plan of Land at 260-276 Merrimac Street, Newburyport, MA Owner: FRCA of Newburyport LLC" by Port Engineering Associates, Inc., dated February 23, 2009 and recorded with the Essex South Registry of Deeds in Plan Book 420, Plan 50, a copy of which is attached hereto and incorporated by reference as Exhibit B-1. Said Property is improved by two (2) principal buildings thereon. This Restriction shall not apply to the multifamily building on the Property constructed in 2008. This Restriction shall apply to the interior and exterior of the building referred to as the "Samuel Morse House / 1690 House", which is adjacent to Merrimac Street, referred to hereinafter as "the Building" described as follows:

A two and a half story Georgian style house with a pitched roof symmetrical five-bay façade, center brick chimney, timber frame and clapboard siding. The house has later 19th century Greek Revival modifications, and retains three historic wood windows, interior wood shutters, brick chimney and fireboxes, entablature and masonry foundation. The key architectural features of the house are described and shown in further detail in the Baseline Documentation.

WHEREAS, the Building and the Property are a contributing resource to the Newburyport Historic District listed in the State and National Registers of Historic Places on August 2, 1984, are historically significant for their architecture, associations, and/or archeology, and qualify for the protections of perpetual preservation restrictions under Massachusetts General Laws, Chapter 184, sections 31, 32 and 33; and

WHEREAS, Grantor and Grantee recognize the architectural, historic and cultural values (hereinafter "preservation values") and significance of the Building and the Property, and have the common purpose of preserving the aforesaid preservation values and significance of the exterior of the Building; and

WHEREAS, the preservation values of the Building values are documented in a series of photographs and documents (hereinafter, "Baseline Documentation") incorporated herein and attached hereto as Exhibits A (Legal Property Description), B-1 (Recorded Plan of Property), B-2 (Detail of Plan of Property), C

(Massachusetts Historical Commission Inventory Form B), D (Baseline Photographic Documentation), and E (Key Architectural Features) which Baseline Documentation the parties agree provides an accurate representation of the Building as of the date hereof.

WHEREAS, the Baseline Photographic Documentation (Exhibit D) approved as a condition of approval of the sale of the Building and Property by the City of Newburyport shall consist of the following Nineteen (19) exterior and interior photographs taken between 2007 and 2017, more specifically:

- A set of 2 exterior photos taken in 2007
- A set of 4 exterior photos taken in April 2015;
- A set of 4 interior photos taken in June 2015;
- A set of 2 interior photos taken in March 2016;
- A set of 3 interior photos taken in March 2017; and
- A set of 4 exterior photos taken in April 2017.

Digital and archival photographic print copies of the Baseline Photographs shall be maintained by the Grantee with an address of:

City of Newburyport
c/o Newburyport Historical Commission
Newburyport City Hall,
60 Pleasant Street
Newburyport, MA 01950

WHEREAS, the Building is in need of preservation and restoration; and will have its exterior restored in accordance with the Restoration Plan (Exhibit G) and;

WHEREAS, the Grantor has received a Special Permit from the City of Newburyport issued December 5, 2007 and filed with the City Clerk December 10, 2007 and recorded in the Essex South Registry of Deed Book 27884 Page 293 as amended by the Special Permit modification issued on July 28, 2015 and filed with the City Clerk on July 28, 2015 and recorded in the Essex South Registry of Deeds Book 34318 Page 361 for the construction and renovation of the structure along with another residential development and the Grantor has agreed to impose a restriction in perpetuity on the Building and Property for the preservation and renovation of the aforementioned Building, under the terms and conditions set forth herein and in such other documents as the parties may execute (the "Restriction" or "Preservation Restriction");

WHEREAS, the Grantor agrees and desires to impose certain restrictions, obligations and duties upon itself, its successors and assigns, so as to maintain, protect and preserve the architectural and historical integrity of the Building; and

WHEREAS, the preservation of the Building is important to the public for the enjoyment and appreciation of its architectural and historical heritage and serves the public interest in a manner consistent with the purposes of Massachusetts General Laws, Chapter 184, Sections 31, 32 and 33 ("Act"); and

WHEREAS, the Commission is authorized to accept preservation restrictions in the name of the City of Newburyport and the Commission is a governmental body duly organized under the laws of the Commonwealth of Massachusetts, including the General Laws, Chapter 40, Section 8D, authorized and directed by the Grantee to manage the Property and Building burdened by such restrictions and to administer and enforce this restriction;

NOW THEREFORE, for good and valuable consideration, the receipt of which is hereby acknowledged, the Grantor does hereby irrevocably grant and convey to the Grantee in gross this Restriction over the Property

and the exterior of the Building and specified interior features of the Building to be administered, managed and enforced by the Commission during the Term of this Restriction.

1. Purpose: It is the purpose of this Restriction to assure that the architectural, historic, and cultural features of the exterior of the Building and specified interior features of the Building, as described and documented in the Baseline Documentation and Exhibit F (Restriction Guidelines) and, will be retained and maintained forever substantially in their historically-appropriate condition for preservation purposes and to prevent any use or change to the exterior of the Building and specified interior features of the Building or the Property that will significantly impair or interfere with the Building's Preservation Values (the "Purpose of this Restriction") and Restoration Plan (Exhibit G). Characteristics that contribute to the architectural and historical integrity of the Property including include, but are not limited to, the setting and location of the Building; and architectural features, materials, appearance, and workmanship of the Building. All Exhibits shall be attached to and recorded with this Restriction.
2. Preservation Restriction: The Grantor grants the grantee the right to forbid or limit:
 - a. Any alteration to the appearance, materials, workmanship, condition or structural stability of the Building unless (i) clearly of minor nature and not affecting the characteristics which contribute to the architectural or historical integrity of the Building and the Property, or (ii) the Grantee has previously determined that it will not impair such characteristics after reviewing plans and specifications submitted by Grantor in accordance with the requirements of paragraph 7, which determination shall not be unreasonably withheld, or (iii) required by casualty or other emergency promptly reported to Grantee in accordance with requirements in paragraph 9. For the purposes of this Agreement, interpretation of what constitutes alterations of a minor nature and ordinary maintenance and repair is governed by the Restriction Guidelines, which are attached hereto as Exhibit F.
 - b. Any alteration to the appearance, materials, workmanship, condition or structural stability of the Building governed by the Newburyport Historical Commission as listed and attached hereto as Exhibit F.
 - c. Any other act or use that may be harmful to the historic preservation of the Building or the Property.
 - d. Notwithstanding anything to the contrary in this section 2, in the event the Grantor is required by law to make improvements to the Building or Property or is required in writing by its insurance carrier to make improvements to the Building or Property in order to avoid revocation of insurance and the Grantor has exhausted all methods of variance or appeal process related to either applicable law or insurance qualifications, the Grantee and the Grantor agree that the Grantee may not forbid or limit the Grantor's ability to make the improvements. Said changes or improvements shall comply with the Secretary of Interior's Standards for the Treatment of Historic Properties with Guidelines for Preserving, Rehabilitating, Restoring and Reconstructing Historic Buildings (36CFR 67 and 68) (hereinafter the "Secretary's Standards"), and shall be designed in consultation with and subject to reasonable review by Grantee.
 - e. Grantor agrees at all times to maintain the exterior of the Building and the Property, the wood interior shutters, the three original windows and the main beams exposed in the second floor and the stone and granite foundation together with the brick arches; the roof, roof line, including the chimneys and form of the building as shown in the baseline documentation and in accordance with this Restriction and in compliance with all Federal, state and local laws, codes and ordinances applicable to the Property and/or the Building. Grantor's obligation to maintain shall require repair, reconstruction and, where necessary, replacement in kind whenever necessary to preserve the Building in a good, sound condition and state of repair.
3. Grantor's Covenants: Covenant to Maintain: Subject to paragraph 2 and the terms and conditions of this Restriction and such other terms and conditions as the Commission may reasonably impose to

accomplish the purposes of this Restriction, the Grantor covenants and agrees at all times to maintain the Building in the same structural condition and state of repair existing as of the date of this Restriction, and thereafter to that existing following the substantial completion of restoration work to be completed. Grantor's obligation to maintain shall require replacement, repair, and reconstruction by Grantor whenever necessary to preserve the exterior of the Building and specified interior features of the Building. Subject to the casualty provisions of paragraphs 9 and 10, this obligation to maintain shall require replacement, rebuilding, repair, and reconstruction of the Building whenever necessary in accordance with the policies and procedures of the Commission and in accordance with the Secretary's Standards.

4. Grantor's Covenants: Prohibited Activities: The following acts or uses are expressly forbidden except as otherwise conditioned in this paragraph:
 - a. The Building shall not be demolished, removed, or razed except as provided in Paragraphs 9 and 10;
 - b. The dumping of ashes, trash, rubbish, or any other unsightly or offensive materials is prohibited on the Property;
 - c. No above-ground utility transmission lines, except those reasonably necessary for the existing Building, may be created on the Property, subject to utility easements already recorded;
 - d. No additions and/or outbuildings may be attached to the Building without prior approval of the Commission; and
 - e. Moving the Building to another location shall be forbidden without prior approval of the Commission.

5. Conditional Rights Requiring Grantee Approval: Subject to Paragraphs 3 and 4, and the terms and conditions of this Restriction and such other terms and conditions as the Commission may reasonably impose to accomplish the purposes of this Restriction, the Grantor shall not alter the Building without prior express written approval of the Commission. Without said approval Grantor shall not make any changes to the Building, including the alteration, partial removal, construction, remodeling, or other physical or structural change, including permanent signs, and any change in material or color or any change to the footprint, size, mass, ridge-line, and rooflines of the Building. Grantor shall similarly not make any alterations to the surrounding Property that would obscure the current view of the Building, such as the installation of permanent signage without approval of the Commission.

Activities by Grantor to maintain the Building and the Property, which are intended to be performed in accordance with the provisions of paragraph 3, and which are of a minor nature, shall not require the prior approval of the Commission. For the purposes of this section, interpretation of what constitutes ordinary maintenance of a minor nature is governed by Restriction Guidelines (Exhibit F), which are attached to this Agreement and hereby incorporated by reference.

6. Grantor's Reserved Rights Not Requiring Further Approval by the Grantee: Subject to the provisions of paragraphs 2 and 4, the following rights, uses and activities of or by Grantor on, over, or under the Property are permitted by this Restriction and by the Commission without further approval by the Commission:
 - a. The right to engage in all those acts and uses that:
 - i. Are permitted by governmental statute or regulation;

- ii. Do not substantially impair the preservation values of the Building and Property; and
 - iii. Are not inconsistent with the Purpose of this Restriction;
 - iv. Without further approval, are in conformance with the Restriction Guidelines attached as Exhibit F and Restoration Plan attached as Exhibit G.
 - b. Pursuant to the provisions of paragraph 3, the right to maintain and repair the Building strictly according to the Secretary's Standards. As used in this sub-paragraph, the right to maintain and repair shall mean the use by the Grantor of in-kind materials and colors, applied with workmanship comparable to that which was used in the construction or application of those materials being repaired or maintained, for the purpose of retaining in good condition the appearance and construction of the exterior of the Building. The right to maintain and repair as used in this sub-paragraph shall not include the right to make changes in appearance, materials, workmanship from that existing prior to the maintenance and repair without the prior approval of the Commission in accordance with the provisions of paragraph 5.
7. Review of Grantor's Requests for Approval: Grantor shall submit to the Commission for the Commission's approval of those conditional rights set out at paragraphs 2 and 5 two copies of information (including plans, specifications, and designs where appropriate) identifying the proposed activity sufficient to permit the Commission to monitor such activity. Within forty-five (45) days of the Commission's receipt of any plan or written request for approval hereunder, the Commission shall certify in writing that (a) it approves the plan or request, or (b) it disapproves the plan or request as submitted, in which case the Commission shall provide Grantor with written suggestions for modification or a written explanation for the Commission's disapproval. Any failure by the Commission to act within forty-five (45) days or receipt of Grantor's submission or resubmission of plans or requests shall be deemed to constitute approval by the Commission of the plan or request as submitted, so long as the request sets forth the provisions of this section relating to deemed approval after the passage of time, provided nothing herein shall be construed to permit Grantor to undertake any of the activities prohibited hereunder.
8. Standards for Review: In exercising any authority created by this Restriction to inspect the Building; to review any construction, alteration, repair, or maintenance; or to review casualty damage or to reconstruct or approve reconstruction of the Building following casualty damage, the Commission shall apply the Secretary's Standards.
9. Casualty Damage or Destruction: In the event the Building or Property shall be damaged or destroyed by fire, flood, windstorm, hurricane, earth movement or other casualty, Grantor shall notify the Commission in writing within fourteen (14) days of damage or destruction, such notification including what, if any, temporary emergency work has already been completed. No repairs or reconstruction of any type, other than temporary emergency work to prevent further damage to the Building and Property and to protect public safety, shall be undertaken by Grantor without the Commission's prior written approval of the work. Within one hundred twenty (120) days of the date of damage or destruction, if required by the Commission, Grantor at its expense shall submit to the Commission a written report prepared by a qualified restoration architect and an engineer who are acceptable to the Grantor and the Commission, which Commission approval shall not be unreasonably withheld, which report shall include the following:
- a. An assessment of the nature and extent of damage;
 - b. A determination of the feasibility of the restoration of the Building and/or reconstruction of damaged or destroyed portions of the Building; and

- c. A report of such restoration/reconstruction work necessary to return the Building to the condition existing at the date hereof or the condition subsequently approved by the Commission.

10. Review After Casualty Damage or Destruction: If, after reviewing the report provided in paragraph 9 and assessing the availability of insurance proceeds after satisfaction of any mortgagee's/lender's claims under paragraph 11, Grantor and the Commission agree that the Purpose of the Restriction will be served by such restoration/reconstruction, Grantor and the Commission shall establish a schedule under which Grantor shall complete the restoration/reconstruction of the Building in accordance with plans and specifications consented to by the parties up to at least the total of the casualty insurance proceeds available to Grantor.

If, after reviewing the report and assessing the availability of insurance proceeds after satisfaction of any mortgagee's/lender's claims under paragraph 11, Grantor and the Commission agree that restoration/reconstruction of the Building is impractical or impossible, or agree that the Purpose of the Restriction would not be served by such restoration/reconstruction and Grantor may, with prior written consent of the Commission, alter, demolish, remove or raze the Building, and/or construct new improvements on the Property. Grantor and Grantee may agree to extinguish this Restriction in accordance with the laws of the Commonwealth of Massachusetts and paragraph 23 hereof.

If, after reviewing the report and assessing the availability of insurance proceeds after satisfaction of any mortgagee's/lender's claims under paragraph 11, Grantor and the Commission are unable to agree that the Purpose of the Restriction will or will not be served by such restoration/reconstruction, the matter may be referred by either party to binding arbitration and settled in accordance with the Commonwealth of Massachusetts arbitration statute then in effect, and all other applicable laws, rules, regulations, and ordinances. Arbitrator shall have experience in historic preservation matters.

11. Insurance: Grantor shall keep the Building insured by an insurance company rated "A-1" or better by Best's for the full replacement value against loss from the perils commonly insured under standard fire and extended coverage policies and comprehensive general liability insurance against claims for personal injury, death and property damage. Property damage insurance shall include change in condition and building ordinance coverage, in form and amount sufficient to replace fully the damaged Building without cost or expense to Grantor or contribution or coinsurance from Grantor. Grantor shall deliver to the Commission, within ten (10) business days of the Commission's written request thereof, certificates of such insurance coverage. Provided, however, that whenever the Property is encumbered with a mortgage or deed of trust nothing contained in this paragraph shall jeopardize the prior claim, if any, of the mortgagee/lender to the insurance proceeds.
12. Indemnification: Grantor hereby agrees to pay, protect, indemnify, hold harmless and defend, at its own cost and expense, Grantee, its boards, commissions, appointees, agents, directors, employees, or independent contractors from and against any and all claims, liabilities, expenses, costs, damages, losses and expenditures (including attorneys' fees and disbursements hereafter incurred) arising out of or in connection with injury to or death of any person as a result of the existence of this Restriction; physical damage to the Building; the presence or release in, on, or about the Property, at any time, of any substance now or hereafter defined, listed or otherwise classified pursuant to any law, ordinance or regulation as a hazardous, toxic, polluting or contaminating substance; or other injury or other damage occurring on or about the Building; unless such injury, death, or damage is caused by Grantee or its boards, commission, appointees, agents, directors, employees, or independent contractors. In the event that Grantor is required to indemnify Grantee pursuant to the terms of this paragraph, the amount of such indemnity, until discharged, shall constitute a lien on the Property with the same effect and priority as a mechanic's lien.

13. Written Notice: Any notice which either Grantor or Grantee may desire or be required to give to the other party shall be in writing;

Grantor: Newburyport Landing LLC
c/o The First Republic Corporation of America
40 East 69th Street
New York, New York, 10021

Grantee: City of Newburyport
c/o Newburyport Historical Commission
Newburyport City Hall
60 Pleasant Street
Newburyport, MA 01950

Each party may change its address set forth herein by a notice to such effect to the other party.

14. Evidence of Compliance: Upon reasonable request by Grantor, Grantee shall promptly furnish Grantor with certification that, to the best of Grantee's knowledge, Grantor is in compliance with the obligations of Grantor contained herein, or that otherwise evidence the status of this Restriction to the extent of Grantee's knowledge thereof.
15. Inspection: With the consent of Grantor, Grantee or its representatives shall be permitted at reasonable times to inspect the exterior of the Buildings and the Property on an annual basis. Grantor covenants not to withhold unreasonably its consent in determining dates and times for such inspections.
16. Grantee's Remedies: The Grantor, for itself, its assigns and successors, expressly acknowledges that a violation of this Preservation Restriction Agreement may result in the Commission exercising its right to enforce the terms and conditions of the Restriction by seeking appropriate legal and equitable relief, including, but not limited to, restoration of the Building and such other legal and equitable remedies as may be available to the Commission to effectuate the purposes of this Restriction and to enforce the Grantor's obligations hereunder.

In the event Grantor is found to have violated any of its obligations, Grantor shall reimburse Grantee for any costs or expenses incurred in connection with Grantee's enforcement of the terms of this Restriction, including all court costs, and attorneys', architectural, engineering, and expert-witness fees. Grantor shall, at its own expense and with approval of Commission, reverse any actions or activities which violated this restriction and altered the Building.

Nothing in this Restriction shall impose upon the Commission any duty to maintain or require that the Building be maintained in any particular state or condition; notwithstanding the Commission's acceptance hereof Enforcement of the terms of this Preservation Restriction shall be at the discretion of the Commission. Any election by the Commission as to the manner and timing of exercising of its right to enforce this Preservation Restriction or otherwise exercise its rights hereunder shall not be deemed or construed to be a waiver of such rights. By its acceptance of this Preservation Restriction, the Commission does not assume any liability or obligation relating to the condition of the Building or the Property, including compliance with hazardous materials or other environmental laws and regulations.

17. Notice from Government Authorities: Grantor shall deliver to Grantee copies of any notice of violation or lien relating to the Buildings or Property received by Grantor from any government authority within five (5) business days of receipt by Grantor. Upon request by Grantee, Grantor shall promptly furnish Grantee with evidence of Grantor's compliance with such notice or lien where compliance is required by law.

18. Notice of Proposed Sale: Grantor shall promptly notify Grantee in writing of any proposed sale of the Property and provide the opportunity for Grantee to explain the terms of the Restriction to potential new Grantors prior to sale closing.
19. Runs with the Land: Except as provided in paragraphs 9 and 10, the restrictions, obligations and duties set forth in this Restriction shall run with the Property and shall inure to the benefit of the Commission and all parties claiming by, through or under the Commission and shall bind the Grantor and all parties claiming by, through or under the Grantor. The rights hereby granted to the Commission constitute the perpetual right of the Commission to enforce this Preservation Restriction Agreement. The Grantor hereby covenants for itself to stand seized and hold title to the Property subject to the terms of respective successors in interest and all persons hereafter claiming under or through Grantor and Grantee, and the words "Grantor", "Grantee" when used herein shall include all such persons. Any right, title, or interest herein granted to Grantee also shall be deemed granted to each successor and assign of Grantee and each such following successor and assign thereof, and the word "Grantee" shall include all such successors and assigns. Anything contained herein to the contrary notwithstanding, Grantor of the Property shall have no obligation pursuant to this instrument where such Grantor shall cease to have any Grantorship interest in the Premises by reason of bona fide transfer. The restrictions, stipulations and covenants contained in this Restriction shall be inserted by Grantor, verbatim or by express reference, in any deed or other legal instrument by which Grantor divests itself of either the fee simple title to or any lesser estate in the Property or any part thereof, including by way of example and not limitation, a lease of all or a portion of the Property.
20. Assignment: Grantee may convey, assign, or transfer this Restriction to a unit of federal, state, or local government, to a local, state, or national charitable corporation or trust that qualifies under the Act, and whose purposes, inter alia, are to promote preservation of historical, cultural, or architectural resources. Conveyance, assignment, or transfer of this Restriction requires that the Purpose for which the Restriction was granted will continue to be carried out. Grantee shall seek Grantor's approval of said conveyance, assignment or transfer and Grantor shall give prior written approval of such conveyance, assignment, or transfer by Grantee, such approval not to be unreasonably withheld.
21. Alternate Designee: Grantee may, at its discretion, remove and replace the Commission as its designee to administer, manage, and enforce this Restriction, provided that any new designee is qualified as such under the Act and other applicable law. In the event Grantee does so remove, the Grantee shall provide notice of same to the Grantor and shall forthwith provide the Grantor with the name, address and further contact information of the designee.
22. Recording and Effective Date: Grantee shall do and perform at its own cost all acts necessary to the prompt recording of this Restriction which shall become effective upon its being duly executed by the Grantor, the City of Newburyport, its being accepted and approved by the Massachusetts Historical Commission, and its being recorded with the Southern Essex District Registry of Deeds.
23. Extinguishment: Grantor and Grantee hereby recognize that an unexpected change in conditions surrounding the Property may make impossible the continued Grantorship or use of the Property for the Purpose of this Restriction and necessitate extinguishment of the Restriction. Such a change in conditions may include, but is not limited to, partial or total destruction of the Building resulting from casualty. Such an extinguishment must meet all the requirements of the Act for extinguishment, including approvals by the City of Newburyport and the Massachusetts Historical Commission following public hearings to determine that such extinguishment is in the public interest. In the event of a sale of the Property, net proceeds of sale shall be paid to Grantor.

24. Condemnation: If all or any part of the Property is taken under the power of eminent domain by public, corporate, or other authority, or otherwise acquired by such authority through a purchase in lieu of a taking, Grantor and Grantee shall join in appropriate proceedings at the time of such taking to recover the full value of those interest in the Property that are subject to the taking and all incidental and direct damages resulting from taking shall be paid out of the recovered proceeds. Such recovered proceeds shall be paid to Grantor.
25. Interpretation: The following provisions shall govern the effectiveness, interpretation, and duration of the Restriction:
- a. Any rule of strict construction designed to limit the breadth of restrictions on alienation or use of the Property shall not apply in the construction or interpretation of this Restriction and this instrument shall be interpreted broadly to affect is Purpose and the transfer of rights and the restrictions on use contained herein.
 - b. This instrument may be executed in two counterparts, one of which is to be retained by Grantor and the other, after recording, to be retained by Grantee. In the event of any disparity between the counterparts produced, the recorded counterpart shall constitute the entire Restriction of the parties.
 - c. This instrument is made pursuant to the Act, but the invalidity of such Act or any part thereof shall not affect the validity and enforceability of this Restriction according to its terms, it being the intent of the parties to agree and to bind themselves, their successors and their assigns in perpetuity to each term of this instrument whether this instrument be enforceable by reason of any statute, common law or private Restriction either in existence now or at any time subsequent hereto.
 - d. Nothing contained herein shall be interpreted to authorize or permit Grantor to violate any ordinance or regulation relating to building materials, construction methods or use. In the event of any conflict between any such ordinance or regulation and the terms hereof Grantor promptly shall notify Grantee of such conflict and shall cooperate with Grantee and the applicable governmental entity to accommodate the purposes of both this Restriction and such ordinance or regulation.

If any court or other tribunal determines that any provision of this instrument is invalid or unenforceable, such provision shall be deemed to have been incorporated herein automatically to conform to the requirements for validity and enforceability as determined by such court or tribunal. In the event any provision invalidated is of such a nature that it cannot be modified, the provision shall be deemed deleted from this Preservation Restriction as though it had never been included herein. In either case, the remaining provisions of this instrument shall remain in full force and effect.

26. Amendment: If circumstances arise under which an amendment to or modification of this Restriction would be appropriate, Grantor and Grantee may by mutual written agreement jointly amend this Restriction, provided that no amendment shall be made that will adversely affect the qualification of this Restriction or the status of Grantee under any applicable law. Any such amendment shall be consistent with the protection of the preservation values of the Property and the Purpose of this Restriction; shall not affect its perpetual duration; shall not permit any private inurement to any person or entity; and shall not adversely impact the overall architectural and historic values protected by this Restriction. Any such amendment shall be effective when the requirements of the Act with respect to amendments have been met and the amendment is recorded in the Southern Essex District Registry of Deeds. Nothing in this paragraph shall require Grantor or Grantee to agree to any amendment or to consult or negotiate regarding any amendment.

- 27. Release: This Preservation Restriction is intended to be a restriction in gross in perpetuity and may only be released, in whole or in party, by the Grantee pursuant to the procedures for release established by the Act and otherwise by law, including approvals following public hearings by the City of Newburyport and the Massachusetts Historical Commission to determine that such a release is in the public interest.
- 28. Archeological Activities: The conduct of archaeological activities on the Property, including without limitation survey, excavation, and artifact retrieval, may occur only following the submission of an archaeological field investigation plan prepared by the Grantor approved in writing by the Grantee and the State Archaeologist of the Massachusetts Historical Commission (M.G.L. C. 9, Sec. 27C, 950 C.M.R. 70.00).
- 29. Revised Baseline Documentation: Following completion of the approved work as specified in the Restoration Plan (Exhibit G), a new set of comprehensive Baseline photographs shall be prepared to be filed with the Grantor and Grantee. Digital and archival photographic print copies of the Baseline Photographs shall be maintained by the Grantee with an address of:

City of Newburyport
 c/o Newburyport Historical Commission
 Newburyport City Hall,
 60 Pleasant Street
 Newburyport, MA 01950

IN WITNESS WHEREOF, the Grantor sets its hand and seal this 30th day of OCTOBER, 2017.
 By:

GRANTOR:

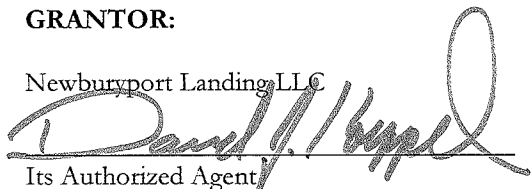
Newburyport Landing LLC

 Its Authorized Agent
 David J. Koeppel, President

New York

New York, ss.

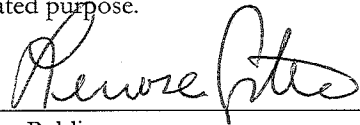
On this 30th day of OCTOBER, 2017, before me, the undersigned notary public, personally appeared David J. Koeppel, as aforesaid, proved to me through satisfactory evidence of identification, which was (a current driver's license) (current U.S. passport) (my personal knowledge of the identity of the principal), to be the person whose name is signed above, and acknowledged the foregoing to be signed by him voluntarily for its stated purpose.

 Notary Public
 My Commission Expires: _____

LENORE GITTO
 Notary Public, State of New York
 No. 01G16124322
 Qualified in Nassau County
 Commission Expires March 28, 2021

ACCEPTANCE BY THE NEWBURYPORT HISTORICAL COMMISSION



Sarah White, duly authorized
Chair, Newburyport Historical Commission

COMMONWEALTH OF MASSACHUSETTS

Essex, ss.

On this 1 day of Dec, 2017, before me, the undersigned notary public, personally appeared Sarah White, as aforesaid, proved to me through satisfactory evidence of identification, which was (a current driver's license) (a current U.S. passport) (my personal knowledge of the identity of the principal), to be the person whose name is signed above, and acknowledged the foregoing to be signed by him voluntarily for its stated purpose.



Notary Public
My Commission Expires: 6-22-2017

ACCEPTANCE AND APPROVAL BY THE CITY OF NEWBURYPORT

I, the undersigned City Clerk of the City of Newburyport, Massachusetts, hereby certify that at a meeting duly held on November 27, 2017, the City Council voted to approve and accept the foregoing Preservation Restriction Agreement for the preservation of the historic resources of said City and being the public interest pursuant to Massachusetts General Laws Chapter 184, Section 32.

CITY OF NEWBURYPORT

By its Clerk

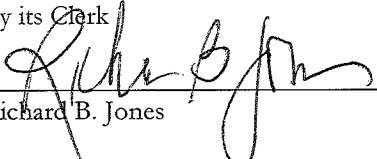
Richard B. Jones

The undersigned hereby certifies that the foregoing preservation restrictions have been approved and accepted by the City of Newburyport

CITY OF NEWBURYPORT

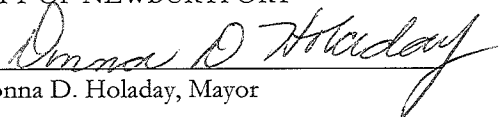

Donna D. Holaday, Mayor

COMMONWEALTH OF MASSACHUSETTS

Essex, ss.

On this 30th day of November, 2017, before me, the undersigned notary public, personally appeared Richard B. Jones, as aforesaid, proved to me through satisfactory evidence of identification, which was (a current driver's license) (a current U.S. passport) (my personal knowledge of the identity of the principal), to be the person whose name is signed above, and acknowledged the foregoing to be signed by him voluntarily for its stated purpose.

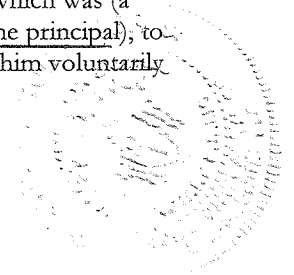

Notary Public
My Commission Expires: 2/27/20



COMMONWEALTH OF MASSACHUSETTS

Essex, ss.

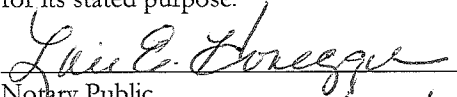
On this 30th day of November, 2017, before me, the undersigned notary public, personally appeared Donna D. Holaday, as aforesaid, proved to me through satisfactory evidence of identification, which was (a current driver's license) (a current U.S. passport) (my personal knowledge of the identity of the principal), to be the person whose name is signed above, and acknowledged the foregoing to be signed by him voluntarily for its stated purpose.

Notary Public
My Commission Expires: 2/27/20

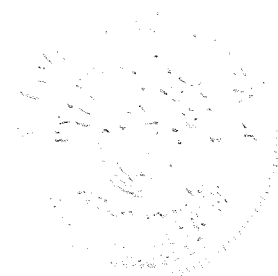

APPROVAL BY THE MASSACHUSETTS HISTORICAL COMMISSION

COMMONWEALTH OF MASSACHUSETTS

The undersigned Executive Director and Clerk of the Massachusetts Historical Commission hereby certifies that foregoing preservation restriction has been approved pursuant to Massachusetts General Law, chapter 184, section 32.

MASSACHUSETTS HISTORICAL
COMMISSION

By: Brona Simon
Brona Simon
Executive Director and Clerk

COMMONWEALTH OF MASSACHUSETTS

Suffolk, ss.

On this 10th day of January, 2018, before me, the undersigned notary public, personally appeared Brona Simon, as aforesaid, proved to me through satisfactory evidence of identification, which was (~~a current driver's license~~) (~~a current U.S. passport~~) (my personal knowledge of the identity of the principal), to be the person whose name is signed above, and acknowledged the foregoing to be signed by him voluntarily for its stated purpose.

Nancy Maida
Notary Public
My Commission Expires: January 25, 2019

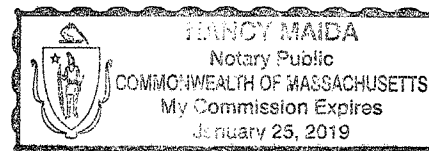

List of Exhibits/Attachments

Exhibit A: Legal Property Description

Exhibit B-1: Recorded Plan of Property

Exhibit B-2: Detail of Plan of Property

Exhibit C: Massachusetts Historical Commission Inventory Form B

Exhibit D: Baseline Photographic Documentation

Exhibit E: Key Architectural Features

Exhibit F: Restriction Guidelines

Exhibit G: Restoration Plan

Exhibit A
Legal Property Description

A certain lot or parcel of land on the easterly side of Merrimac Street, Newburyport, Massachusetts as shown on a plan entitled "Plan of Land at 260-276 Merrimac St., Newburyport MA" by Port Engineering Associates, Inc., dated February 23, 2009 and recorded at the Essex South Registry of Deeds in Plan Book 420, Plan 50 as Lot 2.

Beginning at a point on the easterly sideline of Merrimac Street at other land of FRCA of Newburyport, LLC, said point being the most northwesterly corner of the parcel, thence,

N61 degrees 28' 33" E 49.81' by other land of FRCA of Newburyport LLC to a point, thence,

N64 degrees 26' 33" E 79.12' by other land of FRCA of Newburyport LLC to a point, thence,

N61 degrees 53' 54" E 47.78' by other land of FRCA of Newburyport LLC to a point, thence,

S19 degrees 10' 11" W 115.50' by other land of FRCA of Newburyport LLC to a point, thence,

S71 degrees 05' 04" E 175.48' by other land of FRCA of Newburyport LLC to a point on the easterly sideline of Merrimac Street, thence,

N18 degrees 51' 00" W 87.50' by the easterly sideline of Merrimac Street to the point of the beginning.

Said lot contains 18,064 +/- square feet or 0.415 +/- acres of land area and is shown as Lot 2 on said plan as recorded.

Said lot is subject to and with the benefits of a Tyng Street view corridor all as shown on said plan as recorded.

Exhibit B-1 Recorded Plan of Property

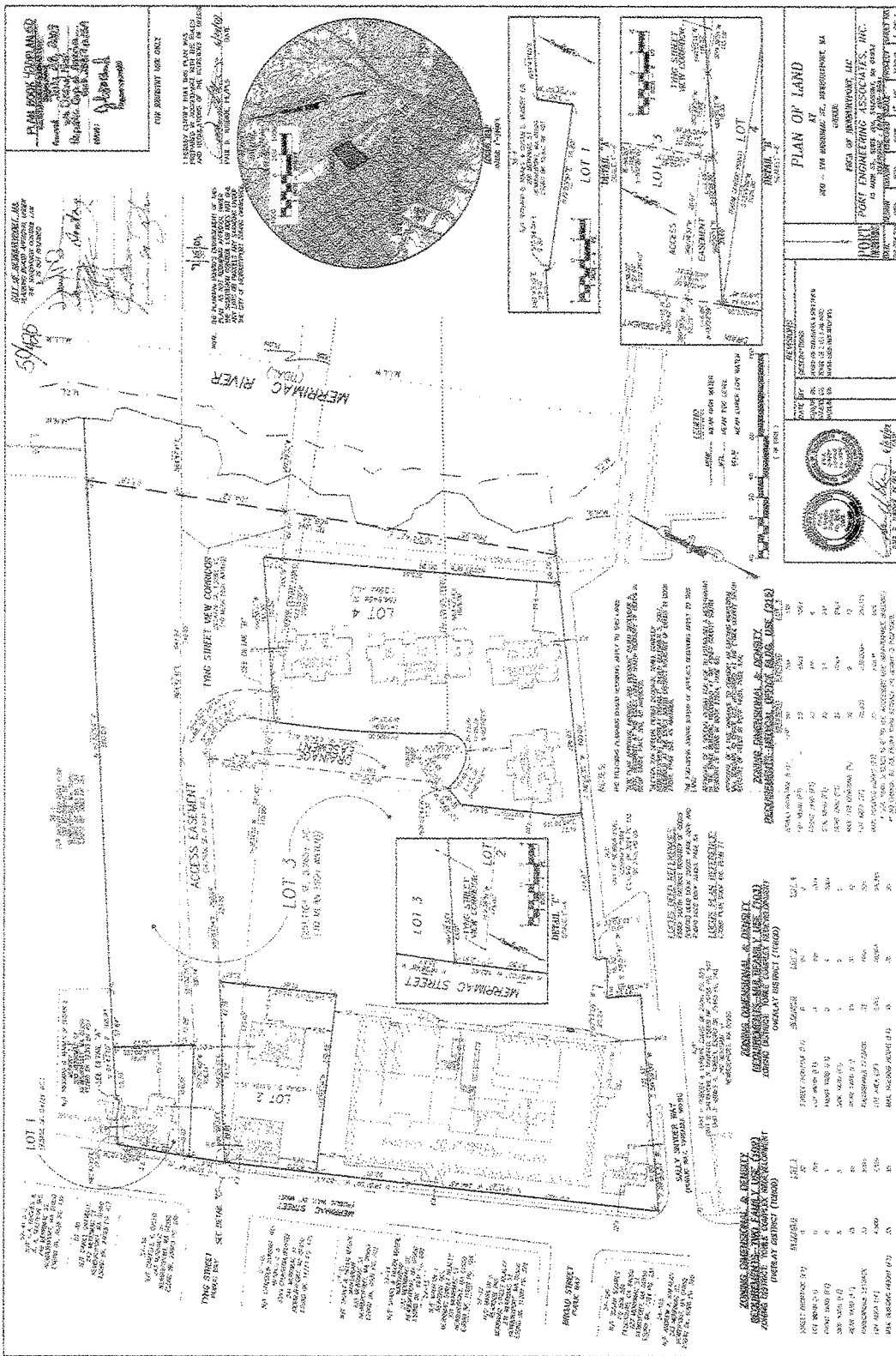

ZONING INFORMATION & DEENSITY

ZONING REGULATORY BODY: [Name]

ZONING DISTRICT: [Name]

LOT	AREA (SQ. FT.)	AREA (ACRES)	DENSITY
LOT 1	10,000	0.23	1.00
LOT 2	10,000	0.23	1.00
LOT 3	10,000	0.23	1.00
LOT 4	10,000	0.23	1.00
LOT 5	10,000	0.23	1.00
TOTAL	50,000	1.15	5.00

OVERLAY DISTRICT (IF ANY):

REMARKS:

Exhibit B-2 Detail of Plan of Property

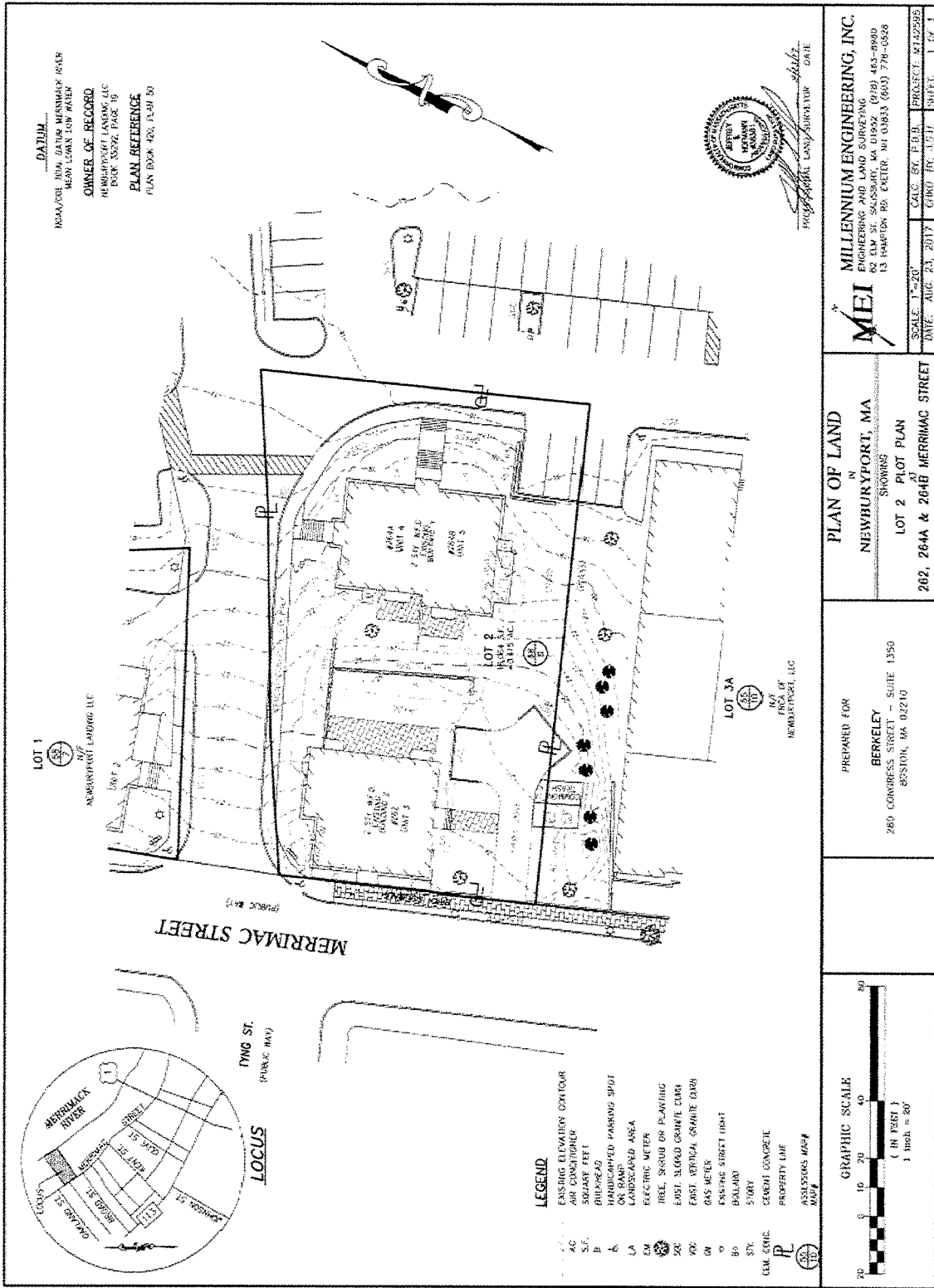

Exhibit C
Massachusetts Historical Commission Inventory Form B

FORM B – BUILDING

MASSACHUSETTS HISTORICAL COMMISSION
MASSACHUSETTS ARCHIVES BUILDING
220 MORRISSEY BOULEVARD
BOSTON, MASSACHUSETTS 02125

Assessor's Number USGS Quad Area(s) Form Number

58-9 Newburyport NWB.L
NRDIS 1984 NWB.L NWB.257/667

Town/City: Newburyport

Place: *(neighborhood or village):*

Photograph



Address: 262-264 Merrimac Street

Historic Name: George Burroughs - Benjamin Choate –
William H. Morse House

Uses: Present: Single-Family Residential

Original: Single-Family Residential

Date of Construction: ca 1773

Source: O.B. Merrill – North End Papers

Style/Form: Georgian

Architect/Builder: George Burroughs

Exterior Material:

Foundation: Fieldstone / Brick

Wall/Trim: Wood Clapboards

Roof: Asphalt Shingles

Outbuildings/Secondary Structures:

Major Alterations *(with dates):*

Rear addition (Late nineteenth century)

Door and window replacement (2016)

Condition: Good

Moved: no yes Date:

Acreage: .41 acres

Setting: Located in a mixed-use area along the west bank of the Merrimack River. The property is located to the north of the Merrimack Arms Manufacturing Company – Towle Manufacturing Company (NWB.255). The surrounding area includes commercial and residential uses on Merrimac Street with a neighborhood of single-family homes to the west.

Locus Map

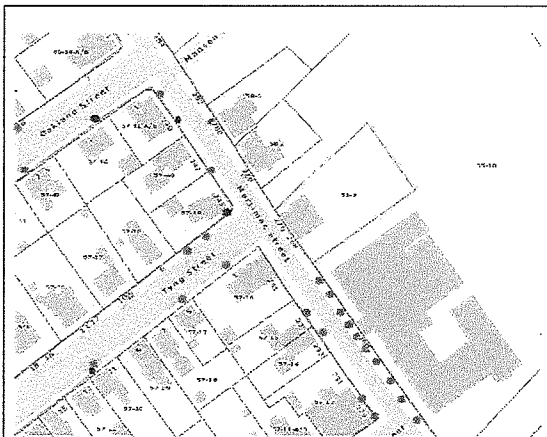

Recorded by: Geoff Melhuish
Organization: Epsilon Associates, INC
Date *(month / year)*: July 2017

INVENTORY FORM B CONTINUATION SHEET

NEWBURYPORT 262-264 MERRIMAC STREET

MASSACHUSETTS HISTORICAL COMMISSION
220 MORRISSEY BOULEVARD, BOSTON, MASSACHUSETTS 02125

Area(s) Form No.

NWB.I	NWB.257/667
NWB.L	

 Listed in the National Register of Historic Places.

Use as much space as necessary to complete the following entries, allowing text to flow onto additional continuation sheets.

ARCHITECTURAL DESCRIPTION:

Describe architectural features. Evaluate the characteristics of this building in terms of other buildings within the community.

262-264 Merrimac Street (NWB.257/667) is a two-story, five-bay wood-frame Georgian style residence. The symmetrical façade with center entry, the second floor windows immediately below the cornice and the side gable roof are all expressive of the Georgian style. The five-by-four bay residence is oriented to the south on the east side of Merrimac Street with a secondary entrance facing the street. The building adopts an L-shaped plan on a low fieldstone foundation and terminates in a side gable roof sheathed with asphalt shingles. The residence is clad with painted wood clapboards. Access to the residence is provided by a centrally located entrance on the south elevation (façade). The opening is set within a simple wood surround with four-light sidelights and a wood pilaster to each side. The five panel wood door, sidelights and surround are replacements installed in 2016. Two, 6/6 double-hung wood sash windows are located to each side of the entry. The sash are set within a projecting wood surround capped by a molded entablature, a Georgian detail. Window openings are stacked above the first floor openings. Second floor windows to the right of the entry feature thin muntins, a later Federal period detail.

A two-story ell projects from the north elevation. The ell terminates in a gable roof sheathed with asphalt shingles. An offset wide brick chimney pierces the roof plane of the ell to the west of the ridgepole. A secondary entrance is located on the west elevation. The opening, like that on the south façade is set within a replacement wood surround with four-light sidelights and a wood pilaster to each side. Two, 6/6 double-hung wood sash windows are located to the north of the entry and a single 6/6 double-hung wood sash entry is located to the south. The sash are set within a projecting wood surround capped by a molded entablature. A second floor window to the right of the entry features a twelve-over-eight double-hung sash, a typical Georgian period detail. A later two-story addition projects from the north and east elevations of the ell. The ell is constructed on a brick foundation and terminates in a hipped roof sheathed with asphalt shingles. Although the property has recently undergone a rehabilitation, the interior of the residence maintains its center-passage plan and features areas of exposed framing, several historic wood-sash windows with original interior shutters on the second floor and exposed brick arch chimney supports in the basement.

HISTORICAL NARRATIVE:

Discuss the history of the building. Explain its associations with local (or state) history. Include uses of the building, and the role(s) the owners/occupants played within the community.

The house is reported, by O.B. Merrill in his *North End Papers 1618-1880 Newburyport, Massachusetts, Development of the North End of the City* to have been built by George Burroughs in 1773 after purchasing the land from Richard Kent. O.B. Merrill reports that Burroughs sold the house and land in 1782 to George Searle for \$900. Burroughs is also credited with constructing 274-276 Merrimac Street (NWB.258) to the north as well. In 1798 the house was sold by Searle's widow, Mary to Jephtha Spaulding and then used the property as a tavern. Benjamin Choate (1770-1856), ship-joiner, acquired the house in 1812 from the estate of Spaulding. It is reported that the property was continued to be used as a tavern for many years and then about 1827 was operated by Pottle Richardson as a "house of entertainment." The property first appears on the 1851 Map of Newburyport as the residence of Benjamin Choate.

Choate's estate sold the house to William H. Morse (1824-1902). Morse was also involved in Newburyport's shipbuilding trade as a ship joiner. The Atlas of Essex County indicates that a boat shop was located to the east of the residence in 1884. The boat shop has since been removed from the property. In the early 20th century, William Morse's son Fred H. Morse (b. 1869) owned the home and worked next door at the Towle Manufacturing Company (NWB.255/2955) as a silversmith, as did his son Fred Jr. as a cabinetmaker. Approximately 1940, Fred Sr. sold the home to the Towle Manufacturing Company for use as a showroom and giftshop. It then became known as the "1690 House" since the Moulton Family (whom Anthony Francis Towle purchased the business from) is credited with making silverware since 1690. 262-264 Merrimac Street remained the showroom and giftshop for the company until 1990 when the plant was closed.

Continuation sheet 1

INVENTORY FORM B CONTINUATION SHEET

NEWBURYPORT 262-264 MERRIMAC STREET

MASSACHUSETTS HISTORICAL COMMISSION
220 MORRISSEY BOULEVARD, BOSTON, MASSACHUSETTS 02125

Area(s) Form No.

NWB.I	NWB.257/667
NWB.L	

BIBLIOGRAPHY and/or REFERENCES:

Ancestry.com, <http://www.ancestrv.com>. Accessed June 20-21, 2017.

McIntyre, Henry. Plan of Newburyport Mass. from an actual survey. Philadelphia: H. McIntyre, 1851. [online at <http://www.nbptpreservationtrust.org/historicmaps>]

Merrill, Oliver B. *North End Papers 1618-1880 Newburyport, Massachusetts, Development of the North End of the City*. Baltimore: Geneological Publishing Company, 2007. Originally published in 1906 and 1908 in the Newburyport Daily News.

Moyes, Marion A. Massachusetts Historical Commission Form B- Building Survey for 268-270 Merrimac Street. Newburyport, MA: Office of Community Development. 1980. [Massachusetts Historical Commission NWB.667]

Stirgwort, Mary Jane. Massachusetts Historical Commission Form B- Building Survey for 262 Merrimac Street. Newburyport, MA: Office of Community Development. 1980. [Massachusetts Historical Commission NWB.257]

Walker, George H. Atlas of Essex County. Boston: Geo H. Walker & Co. 1884. [online at <http://www.nbptpreservationtrust.org/historicmaps>]

ADDITIONAL PHOTOGRAPHS:

262-264 Merrimac Street, Camera facing northwest

Continuation sheet 2

INVENTORY FORM B CONTINUATION SHEET

NEWBURYPORT 262-264 MERRIMAC STREET

MASSACHUSETTS HISTORICAL COMMISSION
220 MORRISSEY BOULEVARD, BOSTON, MASSACHUSETTS 02125

Area(s) Form No.

NWB.J	NWB.257/667
NWB.L	



262-264 Merrimac Street, camera facing northeast



262-264 Merrimac Street, camera facing southwest

Continuation sheet 3

Exhibit D
Baseline Photographic Documentation



1. South elevation 2007



2. Detail of window entablature, 2007



3. Street (west) elevation – April 2015



4. Left (north) elevation – April 2015



5. Rear (east) elevation – April 2015



6. Right (south) elevation – April 2015



7. Basement arch and foundation – June 2015

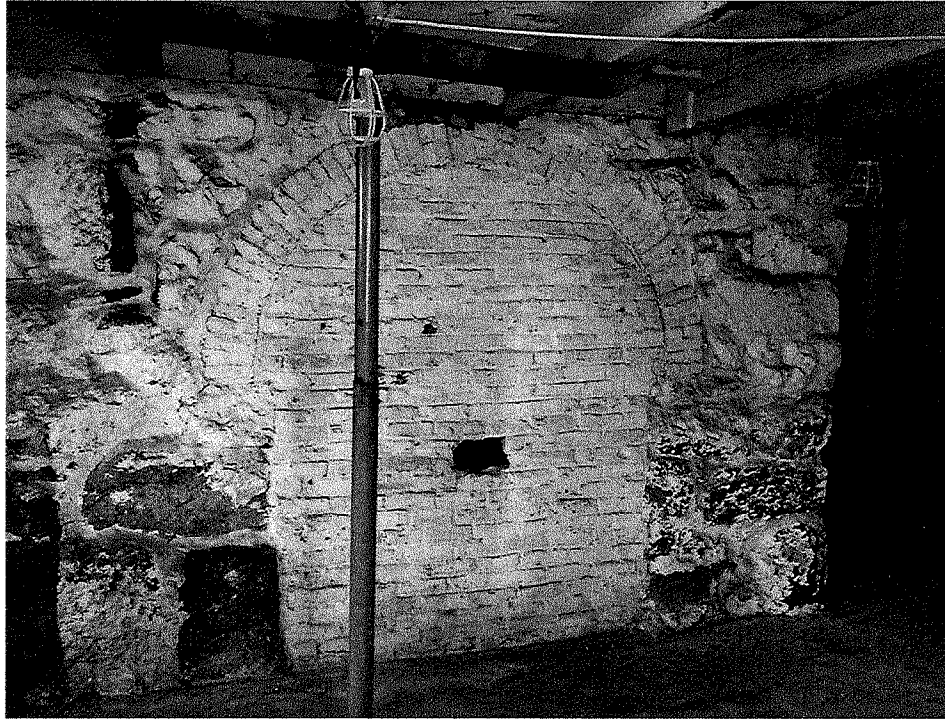

8. Basement arch and foundation – June 2015



9. Basement arch and foundation – June 2015



10. Basement condition – June 2015

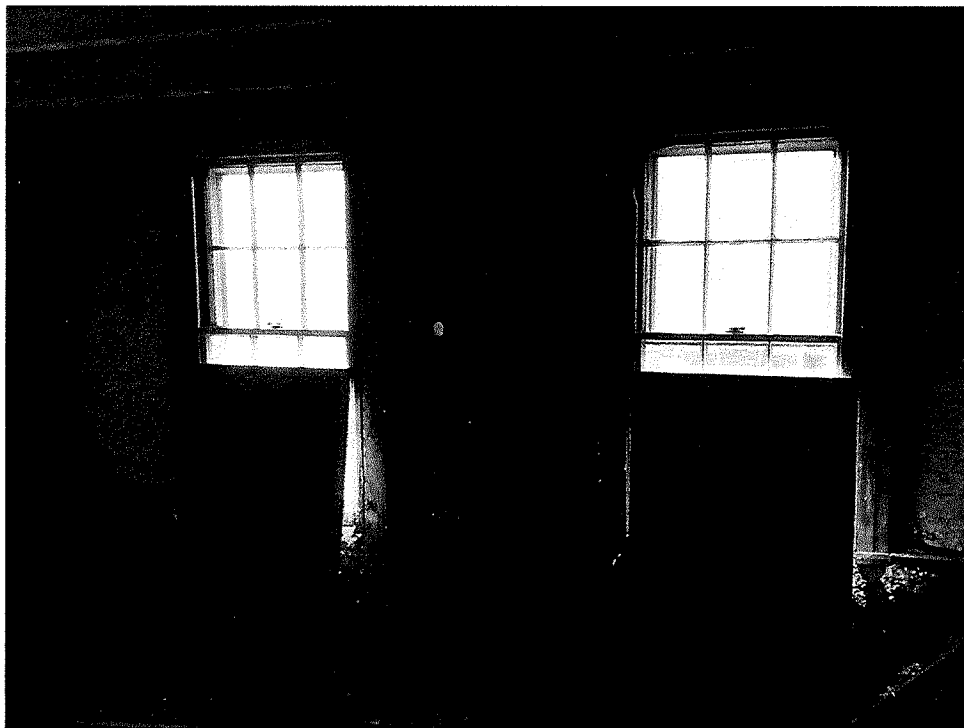

11. Interior shutters beside corresponding windows on second floor, right (south) elevation – March 2016



12. Interior shutters for window on second floor, street (west) elevation –
March 2016



13. Exposed second floor beams – March 2017



14. Exposed beams at second floor master bedroom – March 2017



15. Exposed beams and column in second floor master bedroom – March 2017



16. Street (west) elevation with original window indicated – April 2017



17. Left (north) elevation – April 2017



18. Rear (east) elevation – April 2017



19. Facade (south) elevation with original windows indicated – April 2017

Exhibit E
Key Architectural Features of the Samuel Morse House

Any changes which would impact the exterior envelope of the Building must be reviewed and approved by the Commission prior to receiving a building permit. Changes shall include both repair and replacement of existing key features and historically-accurate restoration where possible of missing or replaced key features. The Commission will give special consideration to changes which will impact the key architectural features (Key Features) of the Building including the following:

Exterior

1. *Form*: Two and a half-story, side-gable main block and two-story rear ell.
2. *Foundation*: Fieldstone, except rear addition which has a brick foundation.
3. *Facade*: Wood clapboard with corner boards.
4. *Roof*: Asphalt shingles, corbelled brick chimney.
5. *South and West Elevation Entrances*: Wood panel doors with sidelights and entablature
6. *Windows*: Historic Wood true-divided 6/6 windows (south elevation second story) and 12/6 (second story west elevation). Replacement windows with consistent and historically accurate muntin patterns located elsewhere.
7. *Cornice*: Box cornice with returns.

Site

Public views: View of Building Merrimac Street.

Interior

1. Form including circulation patterns and division of interior spaces
2. The brick and stone foundation and the brick chimney arches at the basement level.
3. The interior wood shutters.
4. Exposed wood beams
5. Brick fireboxes (concealed behind finished walls)

Exhibit F Restriction Guidelines

The purpose of the Restriction Guidelines is to clarify paragraph three of the terms of the preservation restriction, which deals with alterations to the Property. Under this section permission from the GRANTEE is required for any major alteration. Alterations of a minor nature, which are part of ordinary maintenance and repair, do not require GRANTEE review.

In an effort to explain what constitutes a minor alteration and what constitutes a major change, which must be reviewed by the GRANTEE, the following list has been developed. By no means is this list comprehensive: it is only a sampling of some of the more common alterations, which may be contemplated by the property owner.

PAINT

Minor - Exterior or interior hand scraping and repainting of non-decorative and non-significant surfaces as part of periodic maintenance.

Major - Painting or fully stripping decorative surfaces or distinctive stylistic features including murals, stenciling, ornamental woodwork, stone, masonry, decorative or significant original stucco or plaster.

WINDOWS AND DOORS

Minor - Regular maintenance including caulking, painting and necessary reglazing. Repair or in-kind replacement of existing individual decayed window parts.

Major - Wholesale replacement of units; change in fenestration or materials; alteration of profile or setback of windows. The addition of storm windows is also considered a major change; however, with notification it is commonly acceptable.

EXTERIOR

Minor - Spot repair of existing cladding and roofing including in-kind replacement of clapboards, shingles, slates, etc.

Major - Large-scale repair or replacement of cladding or roofing. Change involving inappropriate removal or addition of materials or building elements (i.e. removal of chimneys or cornice detailing; installation of architectural detail which does not have a historical basis); altering or demolishing building additions; spot repointing of masonry. Structural stabilization of the property is also considered a major alteration.

LANDSCAPE/OUTBUILDINGS

Minor - Routine maintenance of outbuildings and landscape including lawn mowing, pruning, planting, painting, and repair.

Major - Moving or subdividing buildings or property; altering of property; altering or removing significant landscape features such as gardens, vistas, walks, plantings, walls, fences; ground disturbance affecting archaeological resources.

HEATING/AIR CONDITIONING/ELECTRICAL/PLUMBING SYSTEMS

Minor - Repair of existing systems.

Major - Installing or upgrading systems which will result in major exterior appearance changes (i.e. exterior ducts, piping, ventilators, HVAC units); the removal of substantial quantities of original materials in the course of construction.

Changes classified as major alterations are not necessarily unacceptable. Under the preservation restriction such changes must be reviewed by the GRANTEE and their impact on the historic integrity of the property assessed.

It is the responsibility of the property owner to notify the GRANTEE in writing when any major alterations are contemplated. Substantial alterations may necessitate review of plans and specifications.

The intent of the preservation restriction is to enable the GRANTEE to review proposed alterations and assess their impact on the integrity of the building, not to preclude future change. GRANTEE will attempt to work with property owner to develop mutually satisfactory solutions, which are in the best interests of the Property.

**Exhibit G:
Restoration Plan**

Bruner/Cott & Associates

262 Merrimac Street, Newburyport, Massachusetts

Exhibit G

October 30, 2017 revision

MHC Preservation Restriction Intent

Preservation restriction governs massing, roof line, chimney, and general arrangement of windows and door surrounds. Preservation restriction to conserve original historic building form and features that remain intact. West elevation as façade visible from Tyng Street with south elevation as second generally intact entrance frontage seen from Merrimac Street. Original windows, masonry foundation, and upper portions of south entrance surround are original. The north facade of the house was altered under a prior ownership with a two-story, shallow addition and projecting bay window prior to the current ownership.

Significance

The house occupies terminal view-point at the end of Tyng Street, a remarkably continuous double-sided procession of historic houses. Massing and roof outline of the west and south façades are intact- including massive chimney. Fenestration pattern and door locations are unchanged.

Restoration Plan

On south, west, and original north elevations replace aluminum-clad thermal windows (installed 2015) with wood frames and individually glazed multi-paned sashes fitted top and bottom with an interior glass 'energy panel'. Frame, stile, and rail dimensions to match originals that remain in place. Install half-screens externally. Reposition second story windows vertically to correspond to original relationship to eaves. Replace trim at all replacement windows to match original profiles on south, west, and north façades. Replace all affected clapboard siding. Adjust millwork at both entrance doorways to approximate original sidelight and entablature proportions. Continue clapboard paint finish through foundation boards on all four façades.

Restoration Plan Drawings

R-101A, R-102A, R-103A, R-104A, R-105A, R-106A, R-107A, R-108A and photographic renderings for proposed West and South façades. Drawing titles note October 30, 2017 revision. Revisions address window 'entablature' sections and entrance lighting.

South Elevation -

1. Windows -
 - a. Replace- Aluminum clad thermal windows with new wood windows to match dimensions of originals. See drawing for details.
 - b. Position - Raise the three new wooden 2nd floor windows to match the two original windows' placement at eave for second floor.

- c. Trim - Replace trim on new windows to match original. This will result in essentially re-siding of the facade.
- d. Cornice ('entablatures') – Remove existing and adjust dimensions and profile as shown on detailed drawing.
- e. Shutters - Install wood shutters with pintles in trim. Shutters to match those as depicted in the 2007 photos.
- f. Replace full screens with half screens.
- g. Replace exterior storm windows at two 2nd floor original windows with interior storms.

2. Entry -

- a. Door – Replace existing five-panel door with new six-panel leaf, but express the frame at head and continue across sidelights. Retain and protect original cornice and flat portion of the entablature.
- b. Sidelights – Replace sidelights with narrower panes and panel by adding mullions next to pilasters.
- c. Casing and entablature - Modify and replace pilaster per design to reestablish historic proportions, base and capital details.
- d. Light –Position single 5 ½" wide x 11 ½" high , wall-mounted lantern at latch side of door on pilaster. Lantern by House of Antique Hardware, Monte Grande Colonial Style Slate finish (# RS-035SHL-5-254-25).

3. Painting -

- a. Window trim - White.
- b. Shutters - Black.
- c. Clapboard - Repaint gray color to match existing.
- d. Foundation trim - Repaint to match clapboard.
- e. Entry door – Black (gloss).
- f. Entry sidelights - White.
- g. Entry casing and entablature - White.
- h. Corner and cornice trim - White.

West Elevation (Merrimac Street) -

1. Windows -

- a. Replace- Aluminum clad thermal windows with new wood windows to match dimensions of originals. See drawing for details.
- b. Position - Raise the three new windows on the 2nd floor to match the historic windows on the south elevation in placement at eave. Lower attic

window opening to allow restoration of original trim in relation to gable trim.

- c. Trim - Replace trim to match original. This will result in essentially re-siding the facade.
- d. Cornice ('entablatures') – Remove existing and adjust dimensions and profile as shown on detailed drawing.
- e. Shutters - Install wood shutters with pintles in trim. Shutters to match those as depicted in the 2007 photos.
- f. Replace full screens with half screens.

2. Entry -

- a. Door - Replace existing five-panel door with new six-panel leaf, but express the frame at head and continue across sidelights.
- b. Sidelights – Replace sidelights with narrower panes and panel by adding mullions next to pilasters.
- c. Casing and entablature - Modify and replace pilaster per design to reestablish historic proportions, base and capital details.
- d. Light –Position single 5 ½" wide x 11 ½" high, wall-mounted lantern at latch side of door on pilaster. Lantern by House of Antique Hardware, Monte Grande Colonial Style Slate finish (# RS-035SHL-5-254-25).

3. Painting -

- a. Clapboard - Repaint gray color to match existing.
- b. Window trim - White.
- c. Shutters - Black.
- d. Entry door - Keep black (gloss).
- e. Entry sidelights - White.
- f. Entry casing and entablature - White.
- g. Foundation trim - Repaint same color as clapboard.
- h. Corner and cornice trim - Keep white.

North Elevation -

1. Windows -

- a. Replace windows in original house façade as in South and West elevations.
- b. No change to windows in addition.
- c. Replace full screens with half screens.
- d. Trim – Replace to match original window trim at all but bow window.
- e. Replace 'entablatures' at two attic windows.

- f. Shutters - Install wood shutters with pintles in trim. Shutters to match those as depicted in the 2007 photos

2. Painting -

- a. Clapboard - No change, keep same grey.
- b. Window trim - Keep white.
- c. Shutters - Black.
- d. Foundation trim - Repaint same color as clapboard including the extra trim piece at the addition.
- e. Corner and cornice trim - White.
- f. East (Rear) Elevation - No major change due to lack of historic conditions, but add muntin grid to lower sashes to make 6/6 DHSS on five existing windows. Paint trim board at foundation to match clapboards above.

October 30, 2017

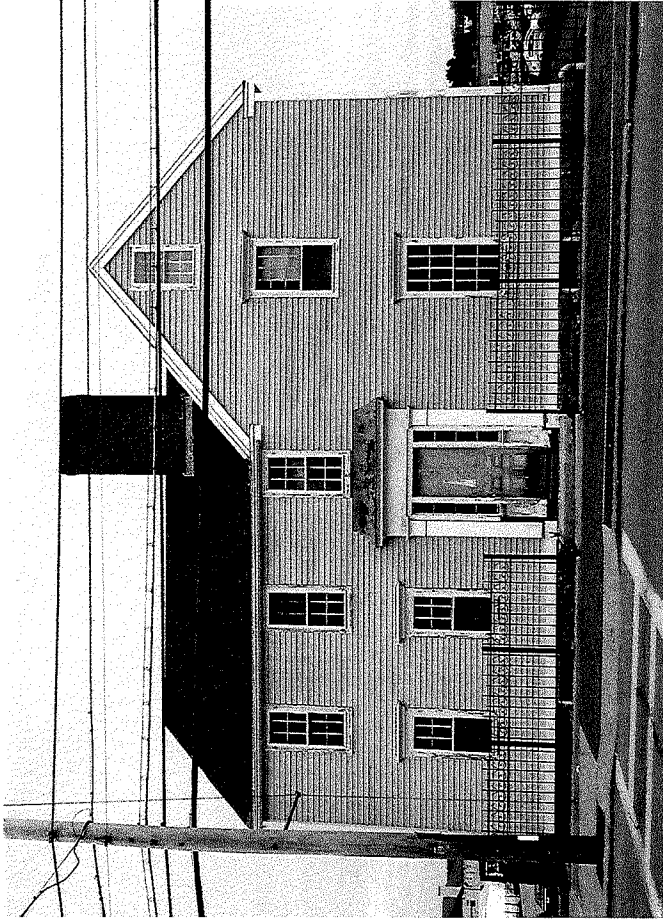

1 WEST ELEVATION PHOTO - 2015
SCALE: 1/4" = 1'-0"

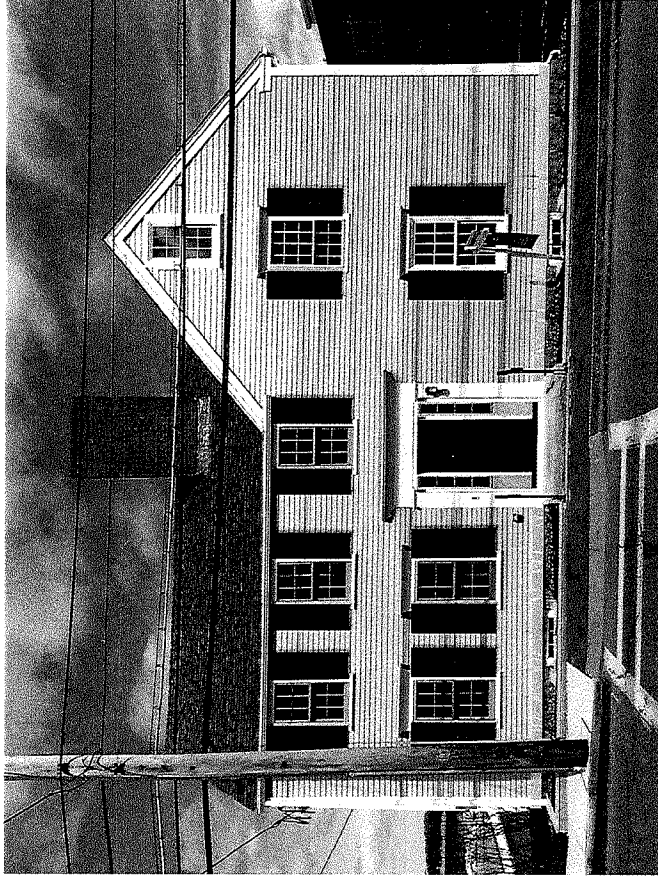

2 PROPOSED WEST ELEVATION PHOTO
SCALE: 1/4" = 1'-0"

1690 HOUSE PRESERVATION RESTRICTION - WEST PHOTO ELEVATION

NEWBURYPORT LANDING
Bunce/Cut & Associates

10/30/2017

RF-102A

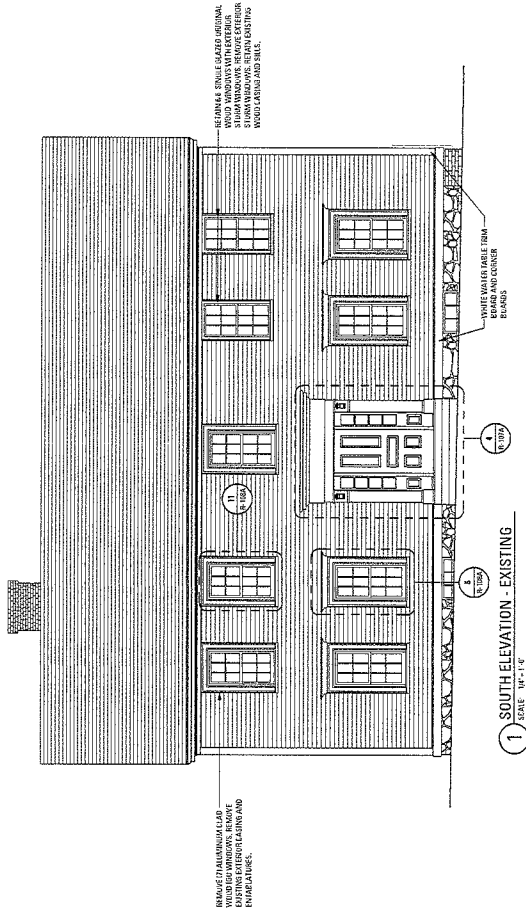

1 SOUTH ELEVATION - EXISTING
SCALE: 1/4" = 1'-0"

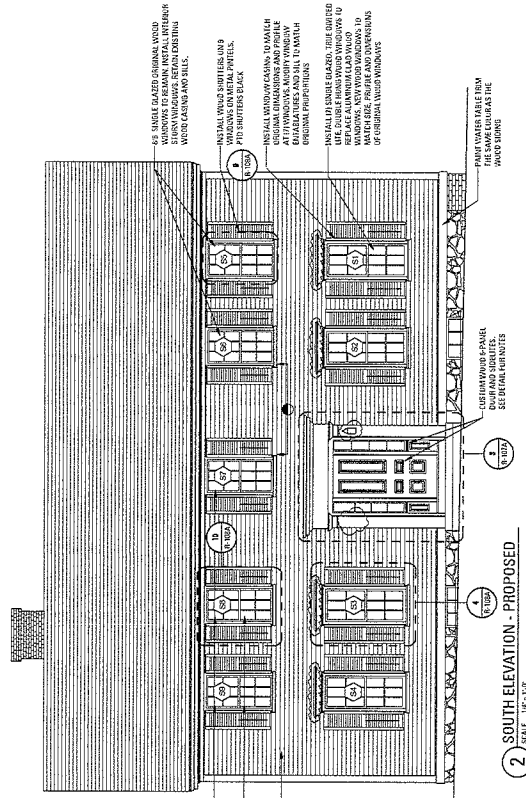

2 SOUTH ELEVATION - PROPOSED
SCALE: 1/4" = 1'-0"

SOUTH ELEVATION WINDOW SCHEDULE

COORD.	FRAME DIMENSIONS	WINDOW TYPE	CASING	SHTTERS	COMMENTS
31	24" x 66"	NEW WOOD SINGLE GLAZED	NEW	NEW WOOD	
32	24" x 66"	NEW WOOD SINGLE GLAZED	NEW	NEW WOOD	
33	24" x 66"	NEW WOOD SINGLE GLAZED	NEW	NEW WOOD	
34	24" x 66"	NEW WOOD SINGLE GLAZED	NEW	NEW WOOD	
35	N/A	SHOWER WOODS DOUBLE GLAZED (SEE ELEVATION FOR DETAILS)	EXISTING	NEW WOOD	REPAIR IMPERVAIRES
36	N/A	SHOWER WOODS DOUBLE GLAZED (SEE ELEVATION FOR DETAILS)	EXISTING	NEW WOOD	REPAIR IMPERVAIRES
37	24" x 66"	NEW WOOD SINGLE GLAZED	NEW	NEW WOOD	SHAKE WINDOW HEAD
38	24" x 66"	NEW WOOD SINGLE GLAZED	NEW	NEW WOOD	SHAKE WINDOW HEAD
39	24" x 66"	NEW WOOD SINGLE GLAZED	NEW	NEW WOOD	INSTALL INTERIOR SHTTERS

VERTICAL DIMENSIONS IN FEET. VERIFY LOCATION OF ORIGINAL WINDOW OPERABLE FOR THE LOCATION OF WINDOW SHTTERS.

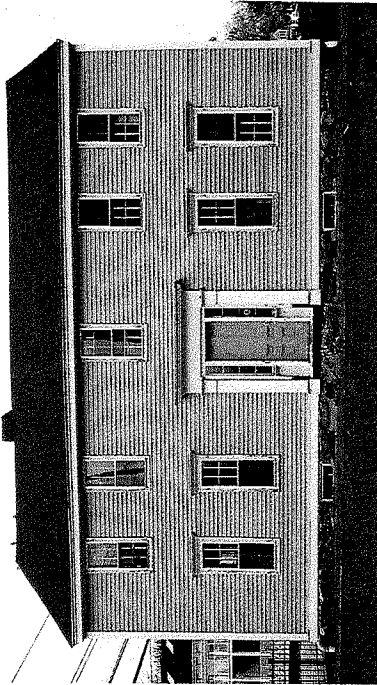

3 SOUTH ELEVATION PHOTO - 2015

1690 HOUSE PRESERVATION RESTRICTION - SOUTH ELEVATION

SCALE: 1/4" = 1'-0"

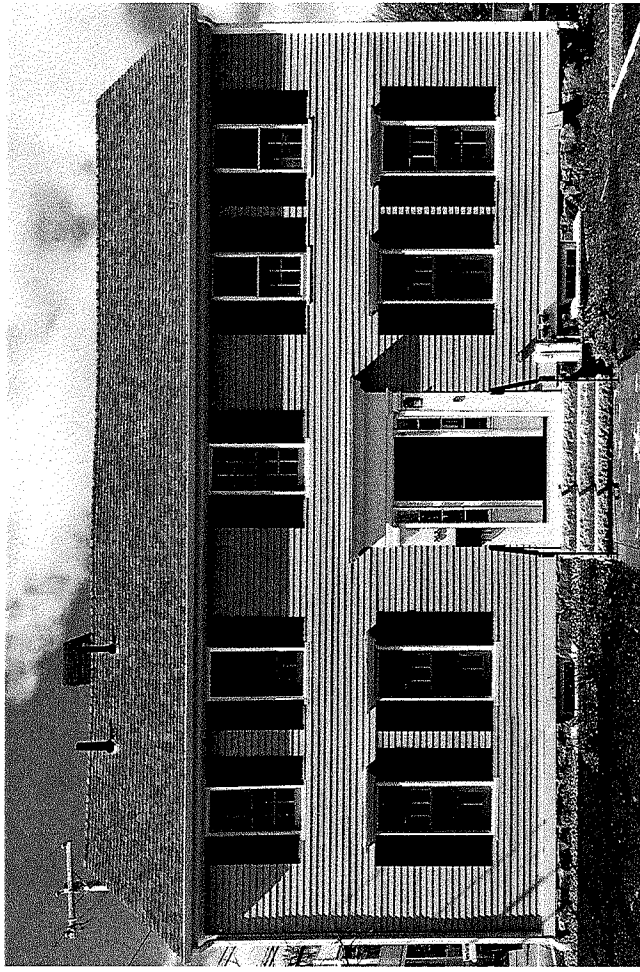

2 PROPOSED SOUTH ELEVATION PHOTO

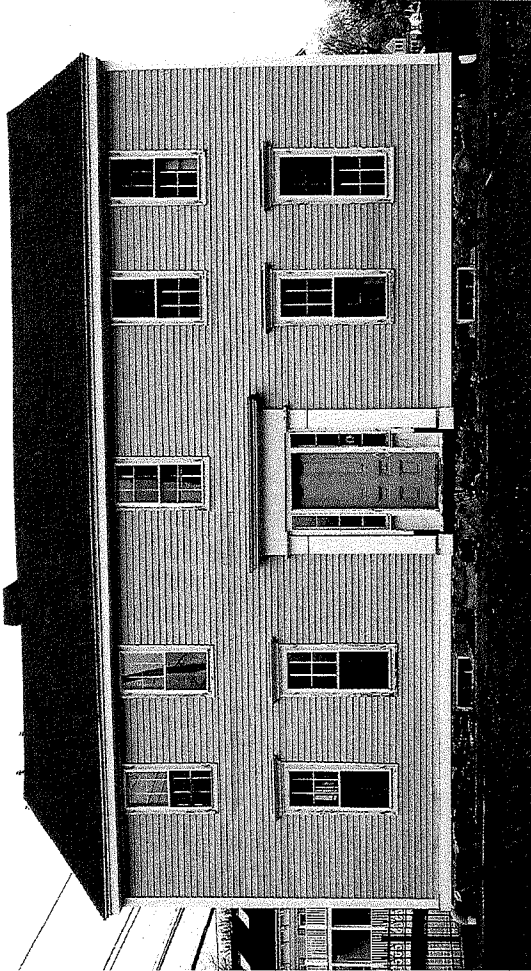

1 SOUTH ELEVATION PHOTO - 2015

1690 HOUSE PRESERVATION RESTRICTION - SOUTH PHOTO ELEVATION
SCALE 1/4" = 1'-0"

NEWBURYPORT LANDING
Bunney/Cott & Associates

10/30/2017

R104A

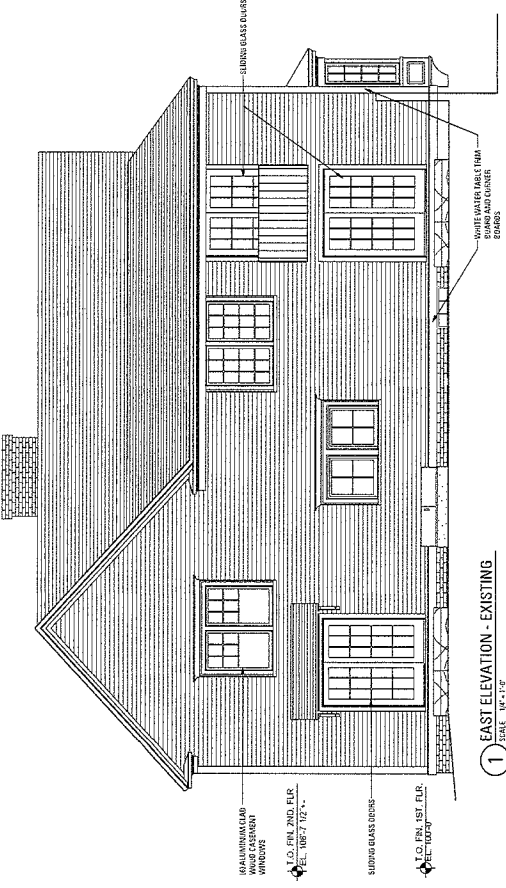

1 EAST ELEVATION - EXISTING
SCALE 1/4" = 1'-0"

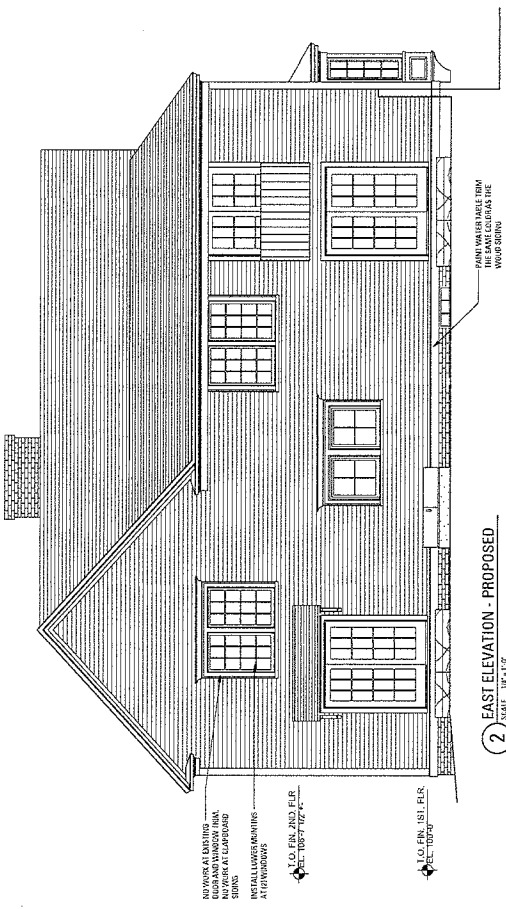

2 EAST ELEVATION - PROPOSED
SCALE 1/4" = 1'-0"



3 EAST ELEVATION PHOTO - 2015
SCALE 1/4" = 1'-0"

1690 HOUSE PRESERVATION RESTRICTION - EAST ELEVATION
SCALE 1/4" = 1'-0"

NEWBURYPORT LANDING
Bursell/Coff & Associates

10/30/2017



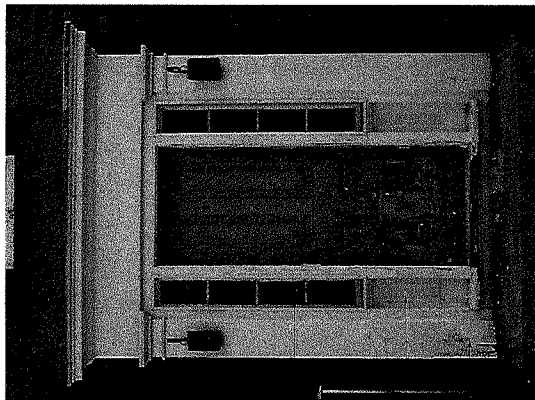

ORIGINAL LUDLOW CAPITAL MOLDING

SINGLE SQUARE WOOD SILLING

PAINTED AND REFINED WOOD MOUNT PANELS

NO BASE AT CURBWAY

9 ENTRANCE DOOR (WEST) - BEFORE 2007
SCALE: 3/4" = 1'-0"

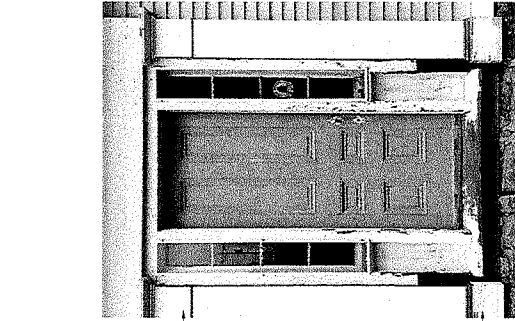

FRAMER TO BE REFINISHED AND PAINTED TO MATCH EXISTING SURROUND

INSTALL 6" x 6" BRASS AND 2" x 4" BRASS

8 ENTRANCE DOOR (SOUTH) - 2015
SCALE: 3/4" = 1'-0"

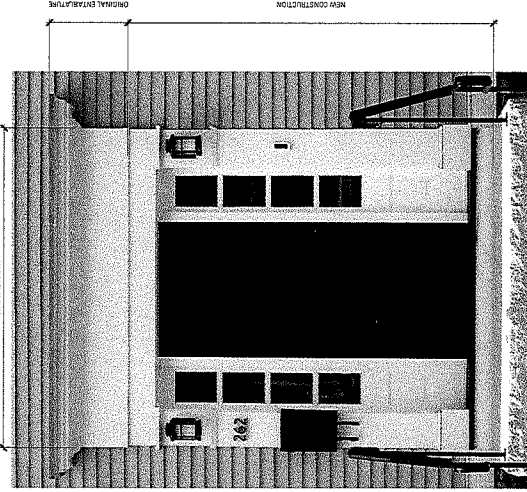

ORIGINAL ENTRAILLATURE

NEW CONSTRUCTION

7 ENTRANCE DOOR (SOUTH) - 2017
SCALE: 3/4" = 1'-0"

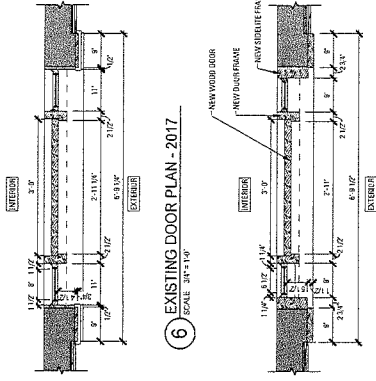

6 EXISTING DOOR PLAN - 2017
SCALE: 3/4" = 1'-0"

5 RESTORATION PLAN DOOR PLAN
SCALE: 3/4" = 1'-0"

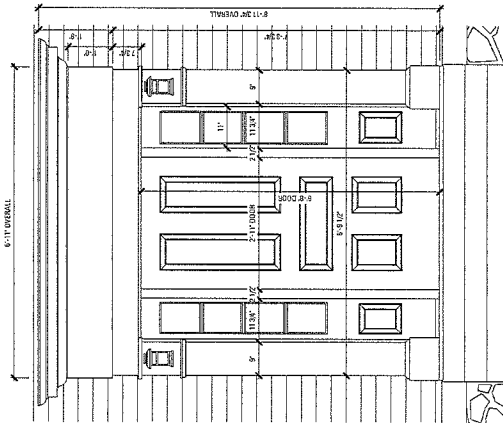

4 EXISTING ENTRY DOOR ELEVATION - 2017
SCALE: 3/4" = 1'-0"

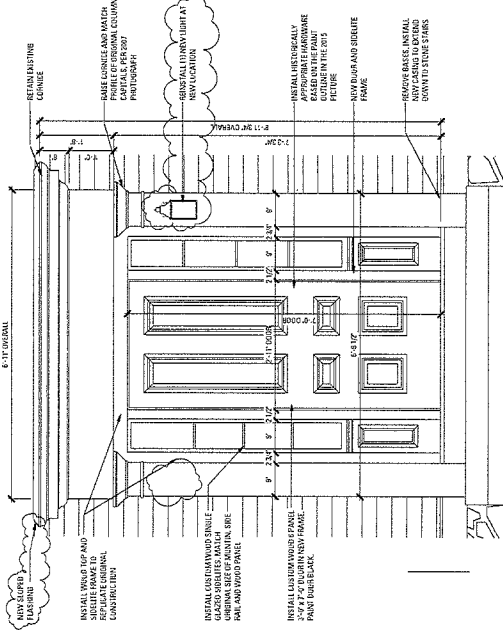

3 RESTORATION PLAN ENTRY DOOR ELEVATION
SCALE: 3/4" = 1'-0"

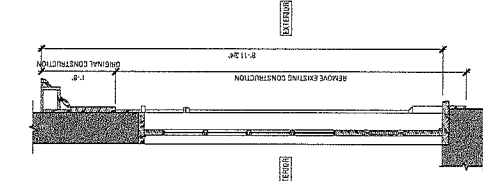

2 EXISTING SECTION THROUGH ENTRY SIDELITE - 2017
SCALE: 3/4" = 1'-0"

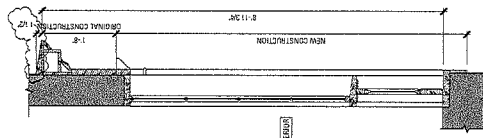

1 RESTORATION PLAN SECTION THROUGH ENTRY SIDELITE - COMPARE TO PHOTO 8
SCALE: 3/4" = 1'-0"

1690 HOUSE PRESERVATION RESTRICTION - DOOR DETAILS

SCALE: 3/4" = 1'-0"

NEWBURYPORT LANDING

Bancroft & Associates

10/30/2017



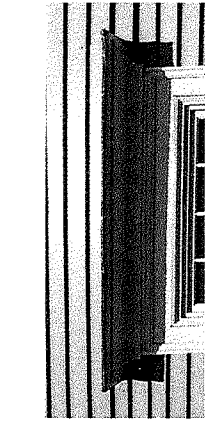

12 EXISTING WINDOW ENTABLATURE - 2017



13 ORIGINAL WINDOW ENTABLATURE

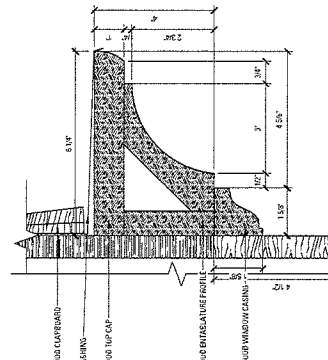

14 EXISTING WINDOW ENTABLATURE SECTION - 2017

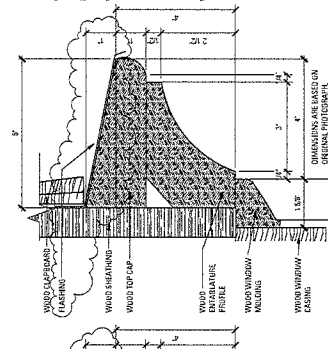

15 ORIGINAL ENTABLATURE SECTION

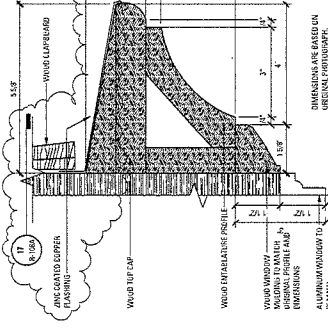

16 RESTORATION PLAN WINDOW ENTABLATURE SECTION



6 ORIGINAL WINDOW CASING TO REPLICATE

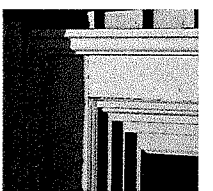

7 EXISTING WINDOW CASING TO BE REMOVED - 2017

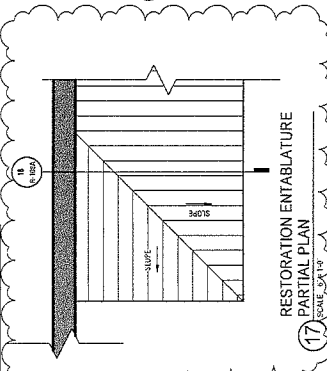

17 RESTORATION ENTABLATURE PARTIAL PLAN

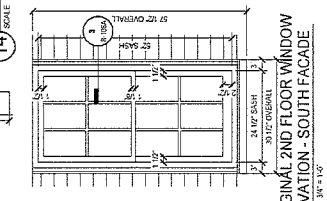

9 ORIGINAL 2ND FLOOR WINDOW ELEVATION - SOUTH FACADE

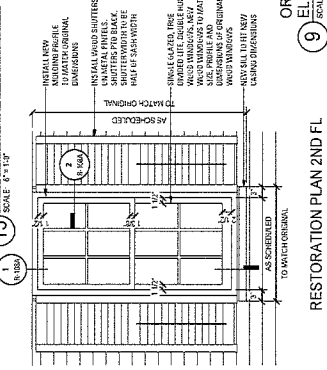

10 RESTORATION PLAN 2ND FL WINDOW ELEVATION

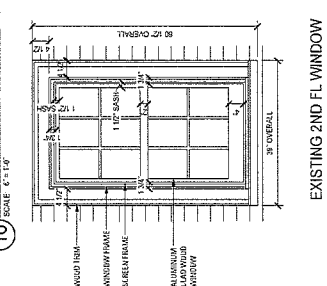

11 EXISTING 2ND FL WINDOW ELEVATION - 2017

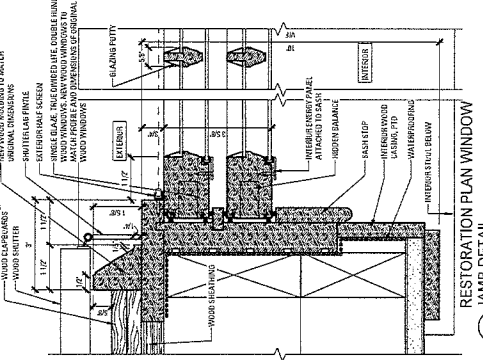

1 RESTORATION PLAN WINDOW HEADSILL DETAIL

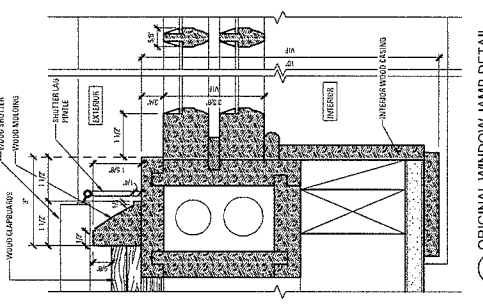

2 RESTORATION PLAN WINDOW JAMB DETAIL

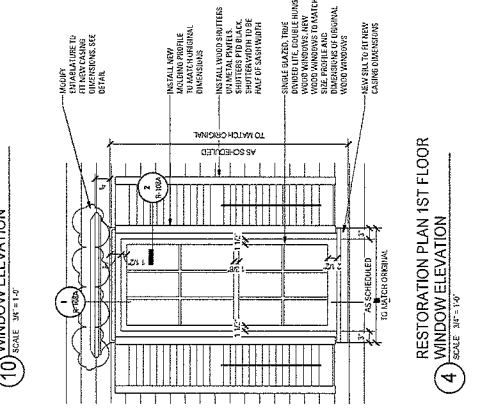

4 RESTORATION PLAN 1ST FLOOR WINDOW ELEVATION

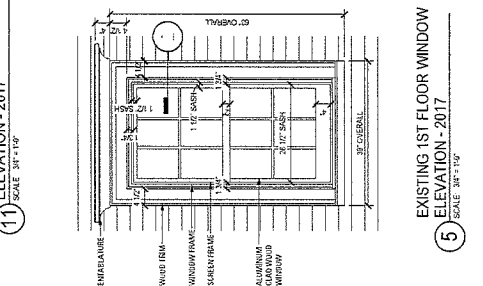

5 EXISTING 1ST FLOOR WINDOW ELEVATION - 2017



10/30/2017

NEWBURYPORT LANDING
Bassett/Carl & Associates

1690 HOUSE PRESERVATION RESTRICTION - WINDOW DETAILS
SCALE: As indicated