

CITY COUNCIL MEETING

AGENDA

May 13, 2024 7:00 pm

City Council Chambers, City Hall

60 Pleasant Street, Newburyport

Zoom details for City Council Meeting:

<https://us02web.zoom.us/j/81299990548>

Or One tap mobile:

US: +19292056099,81299990548#

Or Telephone US: +1 929 205 6099

Webinar ID: 812 9999 0548

- 1. **MOMENT OF SILENCE**
- 2. **PLEDGE OF ALLEGIANCE**
- 3. **CALL TO ORDER**
- 4. **LATE FILE**
- 5. **PUBLIC COMMENT**
- 6. **MAYOR'S COMMENT**

CONSENT AGENDA

NOTE: ALL ITEMS LISTED UNDER CONSENT AGENDA WILL BE ENACTED BY ONE MOTION. THERE WILL BE NO SEPARATE DISCUSSION OF THESE ITEMS. IF DISCUSSION IS DESIRED, THAT ITEM WILL BE REMOVED FROM THE CONSENT AGENDA AND CONSIDERED SEPARATELY.

7. APPROVAL OF MINUTES

April 29, 2024

(Approve)

8. COMMUNICATIONS

- APPL00203_05_13_2024 52 Temple St. Block Party 8/1 Temple St. between Federal and Fair (L&P)
- COMM00552_05_13_2024 Firefighters of Local 827 "Fill the Boot Drive" August 1st, 2nd, & 3rd 10am-4pm (L&P)
- COMM00553_05_13_2024 Mark Murray as City Marshal beginning 5/11/2024 on a temporary basis (PW&S)

9. TRANSFERS

- TRAN00193_05_13_2024 LT Debt - Principal \$28,500 to Elections \$25,000, (B&F)
CLK Dues/Subscriptions \$3,000, CLK Lease Copier \$500
- TRAN00194_05_13_2024 Multiple (see attached) \$3,247,088.76 to (B&F)
FY'25 Special Purpose/Capital Projects - Multiple (see attached) \$3,247,088.76

10. APPOINTMENTS

- APPT00488_05_13_2024 Leslie Eckholdt 36 Warren St., Newburyport Waterfront Trust 2/15/2026 (CS)
- APPT00489_05_13_2024 Curtis Davis 6 Market St., Newburyport Waterfront Trust 7/1/2029 (CS)
- APPT00490_05_13_2024 Robert Koup 36 Lime St., Newburyport Planning Board 7/1/2027 (P&D)

ALL ITEMS NOTED BELOW ARE REMOVED FROM THEIR RESPECTIVE COMMITTEES WITH THE MOTION TO APPROVE THE CONSENT AGENDA

BUDGET & FINANCE

- TRAN00189_04_08_2024 Mayor's Office: General Fund Free Cash \$25,852.84 to
Fire Injured-on-Duty \$25,852.84 (COTW)
- ORDR00554_04_08_2024 Senior Work-Off Program Increase Max. Assistance Amount to \$2000 (COTW)
- TRAN00192_04_29_2024 Finance Dept.: LT Debt-Principal \$80,000 & LT Debt-Interest \$75,000

to Health Insurance Premiums \$155,000

- TRAN00190_04_29_2024
- TRAN00191_04_29_2024
- ORDR00560_04_29_2024
- ORDR00561_04_29_2024
- ORDR00562_04_29_2024

Mayor's Office: Interest on Short-Term Notes \$18,000 to Veterans Benefits \$18,000
 DPS:RRFA-Development Impact Fees \$30,000 to
 Intersection Improvements Study \$30,000
 Gift Acceptance Hinkel Park Bench \$5000
 Gift Acceptance Pioneer League Batting Cage \$30,076.53
 Grant Acceptance Form FY23 FY24 Cultural District Grants \$30,000.00

COMMUNITY SERVICES

- APPT00483_04_08_2024
- COMM00525_01_08_2024
- COMM00541_02_26_2024
- ORDR00474_07_10_2023

Kevin Hunt 14 Tenth St., Newbury Veterans Agent for Newburyport 5/1/2025
 Letter from Joe Morgan re: Frog Pond Restoration Project
 Kim Turner letter including supporting documents COTW)
 Plan Approval Bartlet Mall Improvement Project (COTW)

LICENSES & PERMITS

- APPL00199_04_29_2024
- APPL00200_04_29_2024
- APPL00201_04_29_2024

10th Annual Harborside Half Marathon & 5K Sunday, Nov. 10th 9am-1:30pm
 Tri-State Trek Sat. 6/22 10:30am-2:30pm
 NPS- Kona Ice Truck Waterfront Performing Arts Festival 5/18 1-4pm

PUBLIC WORKS & SAFETY

- APPT00484_04_08_2024
Re-appointment:
- APPT00487_04_29_2024
- ODNC00171_04_29_2024
- COMM00527_01_08_2024

Thomas Baillie 35 Marlboro St. Water Sewer Comm. Alt. 4/30/2026
 Adam Armstrong 5 Buck St. Harbor Commission 6/1/2027
 Amend Ch.13 to move the HP on Pleasant St.
 Letter from Philip Cootey

END OF CONSENT AGENDA

REGULAR AGENDA

9. MAYOR'S UPDATE

10. FIRST READING APPOINTMENTS

11. COMMUNICATIONS

12. TRANSFERS

13. SECOND READING APPOINTMENTS

14. ORDERS

- ORDR00567_04_29_2024
- ORDR00568_05_13_2024
- ORDR00569_05_13_2024
- ORDR00570_05_13_2024
- ORDR00571_05_13_2024

Saltbox Financial Gift \$1810
 Gift Acceptance \$5,000 Lithograph Norman Rockwell
 FY2025 Budget Order
 FY25-29 CIP Order
 Waiver for Asphalt on Willow and Moseley Ave.

15. ORDINANCES

- ODNC00166_03_11_2024
- ODNC00167_04_08_2024
- ODNC00168_04_08_2024
- ODNC00172_05_13_2024

2nd Reading Amend Ch 5-65 Specialized Energy Code (COTW)
2nd Reading Residential Seasonal Dock Fee
2nd Reading HP Spaces
 Zoning Amendment R2 At Hale and Low Street

- ODNC00173_05_13_2024 Amend Ch. 8 Trash Rules and Regs

16. COMMITTEE ITEMS

Budget & Finance

In Committee:

- TRAN00189 04 08 2024 Mayor's Office: General Fund Free Cash \$25,852.84 to Fire Injured-on-Duty \$25,852.84 (COTW)
- ORDR00554 04 08 2024 Senior Work-Off Program Increase Max. Asst. Amount to \$2000 (COTW)
- TRAN00192 04 29 2024 Finance Dept.: LT Debt-Principal \$80,000 & LT Debt-Interest \$75,000 to Health Insurance Premiums \$155,000
- TRAN00190 04 29 2024 Mayor's Office: Interest on Short-Term Notes \$18,000 to Veterans Benefits \$18,000
- TRAN00191 04 29 2024 DPS:RRFA-Development Impact Fees \$30,000 to Intersection Improvements Study \$30,000
- ORDR00560 04 29 2024 Gift Acceptance Hinkel Park Bench \$5000
- ORDR00561 04 29 2024 Gift Acceptance Pioneer League Batting Cage \$30,076.53
- ORDR00562 04 29 2024 Grant Acceptance Form FY23 FY24 Cultural District Grants \$30,000.00
- ORDR00555_04_08_2024 Consolidation of Functions: School Committee with the City (COTW) M.G.L. c.71, §37M
- ORDR00563_04_29_2024 NRYS Bond Debt Exclusion (COTW)

Community Services

In Committee:

- APPT00483 04 08 2024 Kevin Hunt 14 Tenth St., Newbury Veterans Agent for Nbpt 5/1/2025
- COMM00525 01 08 2024 Letter from Joe Morgan re: Frog Pond Restoration Project
- COMM00541 02 26 2024 Kim Turner letter including supporting documents (COTW)
- ORDR00474 07 10 2023 Plan Approval Bartlet Mall Improvement Project (COTW)

General Government

In Committee:

- ORDR00527_01_08_2024 Council Rules 2024
- COMM00550_04_29_2024 Letter re: Newburyport Library and a request for an investigation into HR

Licenses & Permits

In Committee:

- APPL00193_04_08_2024 Ride to End ALZ Saturday, June 1st 8-11am
- APPL00199 04 29 2024 10th Annual Harborside Half Marathon & 5K Sun., Nov. 10th 9am-1:30pm
- APPL00200 04 29 2024 Tri-State Trek Sat. 6/22 10:30am-2:30pm
- APPL00201 04 29 2024 NPS- Kona Ice Truck Waterfront Performing Arts Festival 5/18 1-4pm (with additional documentation)
- APPL00202_04_29_2024 Amendment to a Parklet application APPL00178_02_12_2024

Planning & Development

In Committee:

- COMM00549_04_29_2024 Memo re: MBTA Unit Capacity Options with Attachments (COTW)
- COMM00529_01_29-2024 Letter from Jim McCarthy re: Request to update codified sign ordinances
- COMM00530_01_29_2024 Update Regarding Zoning Studies & Amendments (COTW) Related to Storey Ave & "MBTA Communities"(COTW)
- COMM00534_02_12_2024 Administration Memo re: COMM00529_01_29_2024 (Jim McCarthy letter to request an update codified sign ordinances)

- COMM00540_02_26_2024 Newburyport-MBTA-Communities-Storey-Ave-Slides (COTW)

Public Works & Safety

In Committee:

- APPT00484 04 08 2024 Thomas Baillie 35 Marlboro St. Water Sewer Comm. Alt. 4/30/2026

Re-appointment:

- APPT00487 04 29 2024 Adam Armstrong 5 Buck St. Harbor Commission 6/1/2027
- ODNC00171 04 29 2024 Amend Ch.13 to move the HP on Pleasant St.
- COMM00527 01 08 2024 Letter from Philip Cootey
- COMM00533_02_12_2024 Middle Street Plummer Spring Bridge - Proposed next steps
- COMM00538_02_26_2024 Plummer Spring Bridge Memo
- COMM00544_03_11_2024 Email from Laurie O'Donnell re Flooding at 29 Marquand Lane
- ODNC00169_04_08_2024 Amend Municipal Fees Street Permits
- ODNC00170_04_08_2024 Amend Municipal Parking Facilities
- ORDR00449_04_24_2023 Approving Shared Streets Grant, High Street Traffic Calming
- ORDR00564_04_29_2024 Licensing Agreement between the City of Newburyport and
New England Development for the parking lot at 9 Titcomb St. (COTW)
- ORDR00565_04_29_2024 Licensing Agreement between the City of Newburyport and
New England Development for the parking lot at 90 Pleasant St. (COTW)
- ORDR00566_04_29_2024 G. Mello - Collection and Hauling Contract (5-Year)

17. GOOD OF THE ORDER

18. ADJOURNMENT

CONSENT AGENDA

CITY COUNCIL MEETING

MINUTES

April 29, 2024 7:00 pm

City Council Chambers, City Hall

60 Pleasant Street, Newburyport

Executive Session

Zoom details for City Council Meeting:
<https://us02web.zoom.us/j/81299990548>

Or One tap mobile:

US: +19292056099,81299990548#

Or Telephone US: +1 929 205 6099

Webinar ID: 812 9999 0548

1. **MOMENT OF SILENCE** Remembering Robert Fuller, Paul Tirone
2. **PLEDGE OF ALLEGIANCE**
3. **CALL TO ORDER** 7:00pm the City Clerk called the roll; the following City Councillors answered present: Wright, Zeid, Donahue, Granas, Harman, Khan, Lane, McCauley, Preston, Shand, and Cameron. 11 present.
4. **LATE FILE**
Re-appointment:
 - APPT00487_04_08_2024 Adam Armstrong 5 Buck St. Harbor Commission 6/1/2027 (PW&S)
 - TRAN00192_04_29_2024 Finance Dept.: LT Debt-Principal \$80,000 & LT Debt-Interest \$75,000 to Health Insurance Premiums \$155,000 (B&F)
 - APPL00201_04_29_2024 NPS- Kona Ice Truck Waterfront Performing Arts Festival 5/18 1-4pm (L&P)
 Motion to waive the rules and accept the late files referring them to their respective committees by Councillor Zeid, seconded by Councillor Preston. So voted.
5. **PUBLIC COMMENT**
 Barry Connell, 36 Woodland St.
 Tarah MacGregor, 19 Chestnut St.
 Shannon Flynn, 22 Marquard Ln.
 Patty Myers, 14 Sylvester St.
 Philip Cootey, 22 Phillips St.
 Ted Boretti, 67 Marlboro St.
 Mike Leonard, 13 Tyng St.
 George J. Haseltine, 8 Boardman St.
 Molly Ettenborough, 35 Toppans Ln.
 Frank Weishaupt, 293 High St.
 Kristen Farrell, 28 Spofford St.
 Beth Trach, 144 Low St.
6. **MAYOR'S COMMENT**

CONSENT AGENDA

NOTE: ALL ITEMS LISTED UNDER CONSENT AGENDA WILL BE ENACTED BY ONE MOTION. THERE WILL BE NO SEPARATE DISCUSSION OF THESE ITEMS. IF DISCUSSION IS DESIRED, THAT ITEM WILL BE REMOVED FROM THE CONSENT AGENDA AND CONSIDERED SEPARATELY.

7. **APPROVAL OF MINUTES**
 April 8, 2024

(Approve)

8. COMMUNICATIONS

- APPL00199_04_29_2024 10th Annual Harborside Half Marathon & 5K Sunday, Nov. 10th 9am-1:30pm (L&P)
- APPL00200_04_29_2024 Tri-State Trek Sat. 6/22 10:30am-2:30pm (L&P)
- COMM00549_04_29_2024 Memo re: MBTA Unit Capacity Options with Attachments (P&D/COTW)

9. TRANSFERS

- TRAN00190_04_29_2024 Mayor's Office: Interest on Short-Term Notes \$18,000 to Veterans Benefits \$18,000 (B&F)
- TRAN00191_04_29_2024 DPS:RRFA-Development Impact Fees \$30,000 to Intersection Improvements Study \$30,000 (B&F)

10. APPOINTMENTS

ALL ITEMS NOTED BELOW ARE REMOVED FROM THEIR RESPECTIVE COMMITTEES WITH THE MOTION TO APPROVE THE CONSENT AGENDA

BUDGET& FINANCE

- ORDR00556_04_08_2024 FY21 Perkins Park Project Amendment (COTW)
- ORDR00558_04_08_2024 Bartlet Mall Loan Order (COTW)
- TRAN00188_04_08_2024 Mayor's Office: ARPA State & Local Fiscal Recovery Funds \$964,675.13 to Phillips Drive Project \$700,000 , Marquand Lane Study \$120,000 , and Streets and Sidewalks \$144,675.13 (COTW)
- TRAN00185_03_11_2024 Mayor: ARPA State & Local Fiscal Recovery Funds \$282,653.87 & Joppa Park Walkway \$30,487.91 to Lower Atkinson Common Improvements \$313,141.78 (COTW)
- ORDR00553_04_08_2024 Refunding Bonds
- ORDR00551_04_08_2024 Gift Acceptance Pioneer League Fencing \$13,400
- ORDR00552_04_08_2024 Gift Acceptance FNCOA \$6,316
- ORDR00557_04_08_2024 FY25 CPC Recommendations (COTW)

COMMUNITY SERVICES

- ORDR00537_02_12_2024 Youth and Recreation Center Design Approval (COTW) *Amended*
- APPT00479_03_11_2024 Karen M. Cullinane 88 Federal St. Library Board of 4/15/2031
Newburyport Directors

LICENSES & PERMITS

- APPL00189_03_25_2024 Flag Day 5K Saturday, June 15th 12pm-8pm Cashman Park
- APPL00194_04_08_2024 Pride Parade Saturday, June 1st 11am-4pm Barlett Mall up Brown Square
- APPL00195_04_08_2024 Olive's Maker's Market Saturday, July 20th 9am-1pm High St.
- APPL00196_04_08_2024 Block Party Howard St. between Forrester St. & Chapel St.
Tuesday, June 18th (last day of school) 10am-6pm
- APPL00197_04_08_2024 Lions Yankee Homecoming 10M & 5K Tuesday, July 30th 6-8:30pm
- APPL00198_04_08_2024 Lions Bed Race Thursday, August 1st 5-8pm

PUBLIC WORKS & SAFETY

- APPT00485_04_08_2024 Wilfred“Paul” 7 Hunter Dr. Water/Sewer 2/1/25
Suozzo, Jr. Newburyport Commission
- APPT00486_04_08_2024 Police Marshal Screening Committee (COTW)
- ODNC00168_04_08_2024 HP Spaces
- ORDR00559_04_08_2024 Police Marshal Committee Order (COTW)

END OF CONSENT AGENDA

Motion to collectively approve the Consent Agenda and receive and file the Mayor’s update by Councillor Zeid, seconded by Councillor Lane. So voted.

REGULAR AGENDA

9. MAYOR'S UPDATE

10. FIRST READING APPOINTMENTS

11. COMMUNICATIONS

- COMM00550_04_29_2024 Letter re: Newburyport Library and a request for an investigation into HR Motion to refer to General Government and COTW by Councillor Shand, seconded by Councillor Harman. Roll call vote, 9 yes, 2 no (Zeid, Lane), motion passes.
- APPL00202_04_29_2024 Amendment to a Parklet application APPL00178_02_12_2024 Motion to refer to Licenses & Permits by Councilor McCauley, seconded by Councillor Preston. So voted.

12. TRANSFERS

13. SECOND READING APPOINTMENTS

14. ORDERS

- ORDR00560_04_29_2024 Gift Acceptance Hinkel Park Bench \$5000 Motion to collectively refer ORDR00560, ORDR00561, and ORDR00562 to Budget & Finance by Councillor Zeid, seconded by Councillor Harman. So voted.
- ORDR00561_04_29_2024 Gift Acceptance Pioneer League Batting Cage \$30,076.53 Motion to collectively refer ORDR00560, ORDR00561, and ORDR00562 to Budget & Finance by Councillor Zeid, seconded by Councillor Harman. So voted.
- ORDR00562_04_29_2024 Grant Acceptance Form FY23 FY24 Cultural District Grants \$30,000.00 Motion to collectively refer ORDR00560, ORDR00561, and ORDR00562 to Budget & Finance by Councillor Zeid, seconded by Councillor Harman. So voted.
- ORDR00563_04_29_2024 NRYs Bond Debt Exclusion Motion to refer to Budget & Finance and COTW by Councillor Zeid, seconded by Councillor Preston. Roll call vote, 11 yes, motion passes.
- ORDR00564_04_29_2024 Licensing Agreement between the City of Newburyport and New England Development for the parking lot at 9 Titcomb St.
- ORDR00565_04_29_2024 Licensing Agreement between the City of Newburyport and New England Development for the parking lot at 90 Pleasant St. Motion to collectively refer ORDR00564 and ORDR00565 to Public Works & Safety and COTW by Councillor McCauley, seconded by Councillor Preston. So voted.
- ORDR00566_04_29_2024 G. Mello - Collection and Hauling Contract (5-Year) Motion to refer to Public Works & Safety by Councillor Khan, seconded by Councillor Preston. So voted.

15. ORDINANCES

- ODNC00166_03_11_2024 **Tabled** Amend Ch 5-65 Specialized Energy Code (COTW) Motion to take ODNC00166 off the table by Councillor Shand, seconded by Councillor Khan. So voted. Motion to approve on 1st reading as amended in committee to include the language not to begin “until July 2025” by Councillor Shand, seconded by Councillor Khan. Roll call vote, 7 yes (Wright, Granas, Harman, Khan, Preston, Shand, and Cameron) 4 no (Zeid, Donahue, Lane, McCauley), motion passes.
- ODNC00167_04_08_2024 Residential Seasonal Dock Fee Motion to approve on 1st reading by Councillor Zeid, seconded by Councillor McCauley. Roll call vote, 11 yes, motion passes.
- ODNC00171_04_29_2024 Amend Ch.13 to move the HP on Pleasant St. Motion to refer to Public Works & Safety by Councillor McCauley, seconded by Councillor Preston. Roll call vote, 11 yes, motion passes.

COMMITTEE ITEMS

Budget & Finance

In Committee:

- **ORDR00556 04 08 2024** **FY21 Perkins Park Project Amendment (COTW)**

Motion to approve by Councillor Zeid, seconded by Councillor Preston. So voted.

- **ORDR00558 04 08 2024** **Bartlet Mall Loan Order (COTW)**

Motion to approve by Councillor Zeid, seconded by Councillor Wright. Roll call vote, 11 yes, motion passes.

- **TRAN00188 04 08 2024** **Mayor's Office: ARPA State & Local Fiscal Recovery Funds \$964,675.13 to Phillips Drive Project \$700,000 , Marquand Lane Study \$120,000 , and Streets and Sidewalks \$144,675.13 (COTW)**

Motion to approve by Councillor Zeid, seconded by Councillor Wright. So voted.

- **TRAN00185 03 11 2024** **Mayor: ARPA State & Local Fiscal Recovery Funds \$282,653.87 & Joppa Park Walkway \$30,487.91 to Lower Atkinson Common Improvements \$313,141.78 (COTW)**

Motion to approve by Councillor Zeid, seconded by Councillor McCauley. So voted.

- **ORDR00553 04 08 2024** **Refunding Bonds**

Motion to approve by Councillor Zeid, seconded by Councillor Wright. Roll call vote, 11 yes, motion passes.

- **ORDR00551 04 08 2024** **Gift Acceptance Pioneer League Fencing \$13,400**

Motion to collectively approve ORDR00551 and ORDR00552 by Councillor Zeid, seconded by Councillor Lane. So voted.

- **ORDR00552 04 08 2024** **Gift Acceptance FNCOA \$6,316**

Motion to collectively approve ORDR00551 and ORDR00552 by Councillor Zeid, seconded by Councillor Lane. So voted.

- **ORDR00557 04 08 2024** **FY25 CPC Recommendations (COTW)**

Motion to approve by Councillor Zeid, seconded by Councillor Khan. Roll call vote, 11 yes, motion passes.

- **ORDR00554_04_08_2024** **Senior Work-Off Program Increase Maximum Assistance Amount to \$2000 (COTW)**
- **ORDR00555_04_08_2024** **Consolidation of Functions: School Committee with the City (COTW) M.G.L. c.71, §37M (COTW)**
- **TRAN00189_04_08_2024** **Mayor's Office: General Fund Free Cash \$25,852.84 to Fire Injured-on-Duty \$25,852.84 (COTW)**

Community Services

In Committee:

- **ORDR00537 02 12 2024** **Youth and Recreation Center Design Approval (COTW) Amended**

Motion to approve as amended in committee by Councillor Preston, seconded by Councillor Harman. Roll call vote, 10 yes, 1 no (Zeid), motion passes.

- **APPT00479 03 11 2024** **Karen M. Cullinane 88 Federal St. Library Board of Dir. 4/15/2031**

Motion to approve by Councillor Preston, seconded by Councillor Donahue. Roll call vote, 11 yes Motion passes.

- **APPT00483_04_08_2024** **Kevin Hunt 14 Tenth St., Newbury Veterans Agent for Newburyport 5/1/2025**
- **COMM00525_01_08_2024** **Letter from Joe Morgan re: Frog Pond Restoration Project**
- **ORDR00474_07_10_2023** **Plan Approval Bartlet Mall Improvement Project (COTW)**
- **COMM00541_02_26_2024** **Kim Turner letter including supporting documents COTW**

General Government

In Committee:

- **ORDR00527_01_08_2024** **Council Rules 2024**

Licenses & Permits

In Committee:

- **APPL00189 03 25 2024** **Flag Day 5K Saturday, June 15th 12pm-8pm Cashman Park**

Motion to approve by Councillor Wright, seconded by Councillor McCauley. 9, 0, 2 (Khan, Lane). So voted.

- **APPL00194 04 08 2024** **Pride Parade Saturday, June 1st 11am-4pm Barlett Mall up Brown Square**

Motion to approve by Councillor Wright, seconded by Councillor Harman. 10, 0, 1 (Lane). So voted.

- **APPL00195 04 08 2024** **Olive's Maker's Market Saturday, July 20th 9am-1pm High St.**
Motion to approve by Councillor Wright, seconded by Councillor McCauley. 10, 0, 1 (Harman). So voted.
- **APPL00196 04 08 2024** **Block Party Howard St. between Forrester St. & Chapel St.**
Tuesday, June 18th (last day of school) 10am-6pm
Motion to approve by Councillor Wright, seconded by Councillor McCauley. 10, 0, 1 (Harman). So voted.

- **APPL00197 04 08 2024** **Lions Yankee Homecoming 10M & 5K Tuesday, July 30th 6-8:30pm**
Motion to collectively approve APPL00197 and APPL00198 by Councillor Wright, seconded by Councillor McCauley. 10, 0, 1 (Harman). So voted.
- **APPL00198 04 08 2024** **Lions Bed Race Thursday, August 1st 5-8pm**
Motion to collectively approve APPL00197 and APPL00198 by Councillor Wright, seconded by Councillor McCauley. 10, 0, 1 (Harman). So voted.
- **APPL00193_04_08_2024** Ride to End ALZ Saturday, June 1st 8-11am

Planning & Development

In Committee:

- **COMM00529_01_29-2024** Letter from Jim McCarthy re: Request to update codified sign ordinances
- **COMM00530_01_29_2024** Update Regarding Zoning Studies & Amendments (COTW)
Related to Storey Ave & "MBTA Communities"(COTW)
- **COMM00534_02_12_2024** Administration Memo re: COMM00529_01_29_2024
(Jim McCarthy letter to request an update codified sign ordinances)
- **COMM00540_02_26_2024** Newburyport-MBTA-Communities-Storey-Ave-Slides (COTW)

Public Works & Safety

In Committee:

- **APPT00485 04 08 2024** **Wilfred "Paul" Suozzo, Jr.** **7 Hunter Dr. Newburyport** **Water/Sewer Commission** **2/1/25**
Motion to approve by Councillor McCauley, seconded by Councillor Granas. Roll call vote, 11 yes, motion passes.
- **APPT00486 04 08 2024** **Police Marshal Screening Committee (COTW)**
Motion to collectively approve APPT00486 and ORDR00559 by Councillor McCauley, seconded by Councillor Granas. Roll call vote, 11 yes, motion passes.
- **ODNC00168 04 08 2024** **HP Spaces**
Motion to approve on 1st reading by Councillor McCauley, seconded by Councillor Shand. Roll call vote, 11 yes, motion passes.
- **ORDR00559 04 08 2024** **Police Marshal Committee Order (COTW)**
Motion to collectively approve APPT00486 and ORDR00559 by Councillor McCauley, seconded by Councillor Granas. Roll call vote, 11 yes, motion passes.
- **APPT00484_04_08_2024** Thomas Baillie 35 Marlboro St. Water Sewer Comm. Alt. 4/30/2026
- **COMM00527_01_08_2024** Letter from Philip Cootey
- **COMM00533_02_12_2024** Middle Street Plummer Spring Bridge - Proposed next steps
- **COMM00538_02_26_2024** Plummer Spring Bridge Memo
- **COMM00544_03_11_2024** Email from Laurie O'Donnell re Flooding at 29 Marquand Lane
- **ODNC00169_04_08_2024** Amend Municipal Fees Street Permits
- **ODNC00170_04_08_2024** Amend Municipal Parking Facilities
- **ORDR00449_04_24_2023** Approving Shared Streets Grant, High Street Traffic Calming

16. GOOD OF THE ORDER

Motion to waive the rules to go past 10:30 pm by Councillor Wright, seconded by Councillor Khan. So voted.

10:10 pm 10-minute recess per City Council President Cameron

17. EXECUTIVE SESSION:

Pursuant to MGL c. 30A s. 21 (3) there will be an executive session for the purpose of discussing strategy with respect to potential litigation.

Pursuant to MGL c. 30A s. 21 (1) there will be an executive session for the purpose discussing the reputation, character, physical condition or mental health, rather than professional competence, of an individual, or to discuss the discipline or dismissal of, or complaints or charges brought against, a public officer, employee, staff member or individual.

Motion to go into Executive Session for the following reasons:

Pursuant to MGL c. 30A s. 21 (3) there will be an executive session for the purpose of discussing strategy with respect to potential litigation and the President declares that such discussion in Open Session may have a detrimental effect on the litigation.

Pursuant to MGL c. 30A s. 21 (1) there will be an executive session for the purpose discussing the reputation, character, physical condition or mental health, rather than professional competence, of an individual, or to discuss the discipline or dismissal of, or complaints or charges brought against, a public officer, employee, staff member or individual.

The President states that the Council will not be coming back out to Regular Session

By Councillor Cameron, seconded by Councillor Shand. Roll call vote, 11 yes, motion passes.

18. ADJOURNMENT

COMMUNICATIONS

RECEIVED
CITY CLERK'S OFFICE
NEWBURYPORT, MA

2024 APR 24 A 11:20

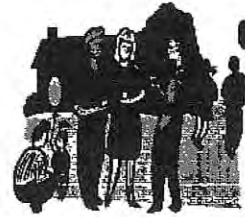

CITY OF NEWBURYPORT
60 PLEASANT STREET
NEWBURYPORT, MA 01950

BLOCK PARTY APPLICATION

Please fill out the application below and obtain the approving signatures for the street closure. Mail or drop off the completed signed application at: City Clerk's Office, City Hall, 60 Pleasant St., Newburyport, MA 01950 at least 8 business days prior to a City Council meeting. The requested Block Party needs approval by the City Council. For any questions, please contact The City Clerk's Office at (978)465-4407.

Block Party

DATE OF REQUEST: August 1, 2024

4/19/2024

CONTACT INFORMATION

FIRST AND LAST NAME: Ghlee Woodworth

MAILING ADDRESS: 52 Temple St

PHONE NUMBER: 978 465-2010

E-MAIL ADDRESS: pcbahati@yahoo.com

BLOCK PARTY INFORMATION

BLOCK PARTY DATE: August 1, 2024

DESIRED STREET CLOSING LOCATION: Temple St - Federal to Fair St.

Please indicate cross streets when requesting the closing of street sections

STREET TO BE BARRICADED: Temple St - Between Federal + Fair Streets

DESIRED STREET CLOSING TIME: 6 pm to 10 pm

Block Parties should run no later than 10:00 p.m.

August 1 Bed Race start time

Susan Crawford
Marie Roy

one way

Streets

We provide saw horse + signs. Very successful and Fun! Children are safe! About 9 years,

REGULATIONS

By signing, I agree that I am a legal adult 18 years of age or older and understand this permit does not release me of any liability for damages that may result from the conducting of this Block Party. Further, I agree to comply with all requirements listed below:

I understand that applications for block party permits may take up to four weeks to process.

Block parties will be conducted only on low-volume residential streets, dead-end streets, or cul-de-sacs, No thoroughfares or collector streets may be used.

It is hereby agreed that, by signing and presenting this application, signer(s) represents to the City of Newburyport that the following statements are true and correct, and agrees to and will abide by the following:

1. All residents living on the street or block for which the party is planned request the Block party, or have been contacted and do not object to the Block Party.
2. To be responsible for placement, maintenance and removal of barricades.
3. A block party permit does not allow the sale of alcohol or the consumption of alcohol on public property (in city streets, sidewalks, parks, etc.) alcohol is allowed only on private property. All state and city alcohol laws still apply during Block Parties.
4. Amplified music shall be permitted with permission of the City Council.
5. To leave **AT LEAST a TWELVE (12) FOOT AISLE** in the street to permit passage of emergency vehicles or vehicles of residents. Failure to maintain a ten foot aisle during the entire period of the party will necessitate denial of requests for subsequent block parties. **Public safety personnel will monitor the party for strict adherence to this rule.**
6. To maintain adult supervision at all times during the party.
7. Applicant(s) shall be responsible for the pick-up of trash and garbage within 2 hours of the end the party.
8. Streets may not be barricaded later than 10:00 P.M.
9. No residents of the area designated shall be prohibited from attending the party.
10. No such activity may be conducted within 500 feet of any school, church, hospital, nursing home or similar operation unless endorsed by the management of such institution e
11. Only approved readily removable Barricades will be permitted such as, orange cones and sawhorses with a sign. No vehicles will permitted to be used as a Barricade.
12. Block parties are permitted 10AM-10PM

Applicant Signature

[Handwritten Signature]

Date

4/24/2024

APPROVAL SIGNATURES REQUIRED FOR STREET CLOSURE

CITY MARSHALL

4 Green Street

FIRE CHIEF

Greenleaf Street

DEPUTY DIRECTOR

1 Perry Way

CITY CLERK

60 Pleasant St.

[Signature] 4/23/24

[Signature] 4/22/24

[Signature] 4/19/24

City use only:

Approved _____

-Denied _____

Date _____



CITY OF NEWBURYPORT

FIRE DEPARTMENT

0 Greenleaf Street, Newburyport, MA 01950
(978) 465-4427 FAX (978) 463-9177

Stephen H. Bradbury
Fire Chief

Barry Salt
Acting Deputy Chief

May 5, 2024

Mr. Richard Jones, City Clerk
City of Newburyport

Barry Salt, Acting Deputy Fire Chief
Newburyport Fire Department

Muscular Dystrophy Support Letter

Mr. Jones,

This letter is to acknowledge that the Newburyport Fire Department Supports the Firefighters of Local 827 Annual "Fill the Boot drive" in Market Square during Thursday, Friday and Saturday of Yankee homecoming and therefore request permission from the City Council.

This is a long-standing tradition of fund raising for such a worthy cause. We look to continue this tradition on August 1, 2 and 3 from 10 am-4 pm.

As always, we thank you for your support of this continued event.

Barry Salt, Provisional Deputy Fire Chief



CITY OF NEWBURYPORT
OFFICE OF THE MAYOR
SEAN R. REARDON, MAYOR

RECEIVED
CLERK'S OFFICE
NEWBURYPORT, MA
2024 MAY -7 A 10:56

60 PLEASANT STREET - P.O. Box 550
NEWBURYPORT, MA 01950
978-465-4413 PHONE
MAYOR@CITYOFNEWBURYPORT.COM

May 6, 2024

Dear Clerk Jones,

Pursuant to Section 3-5 of the City Charter, I am designating Mark Murray to perform the duties of the office of City Marshal on a temporary basis beginning May 11th until the office can be filled by the selection process ordered by Section 2-316 of the City's Code of Ordinances. I certify that Marshal Murray is qualified to perform the duties which will be required and that I make this designation solely in the interests of the City of Newburyport.

The Hiring Committee for the City Marshal position has been approved by the City Council and will be meeting to begin the hiring process. The process is expected to last no more than five months.

This Acting City Marshal Appointment is valid for 90 days and may be given two 30-day extensions, according to our Charter. I will be in communication should an extension be necessary.

Respectfully,

Sean R. Reardon
Mayor

TRANSFERS



CITY OF NEWBURYPORT FY 2024

RECEIVED
CITY CLERK'S OFFICE
NEWBURYPORT, MA

2024 MAY 8 P 3:46

TRANSFER/APPROPRIATION REQUEST

Department: City Clerk

Submitted by: Richard B. Jones, City Clerk

Date Submitted: 5/13/2024

Transfer From:

Account Name:	LT Debt - Principal	Balance:	\$ 85,000.00
Account Number:	0720009-59100	Category:	\$ 163,973.67
Amount:	\$28,500.00	Trans I/O:	\$ -

Why Funds Are Available:

A surplus is anticipated at year-end due to the timing of debt issuance this fiscal year.

Transfer To:

Account Name:	BDR Elections	Balance:	\$ (21,508.39)
Account Number:	01163007-57808	Category:	\$ (20,942.23)
Amount:	\$25,000.00	Trans I/O:	\$ -

Why Funds Are Needed:

Additional funding is needed to cover elections work this fiscal year. A portion of these costs are reimbursable by the state, however funds will not be received until next fiscal year and any deficit must be covered by year-end.

Transfer To:

Account Name:	CLK Dues/Subscriptions	Balance:	\$ 80.10
Account Number:	01161007-57300	Category:	\$ 80.10
Amount:	\$3,000.00	Trans I/O:	\$ -

Why Funds Are Needed:

A deficit is anticipated at year-end due to higher subscription costs for the department.

Transfer To:

Account Name:	CLK Lease Copier	Balance:	\$ 110.00
Account Number:	01161002-52701	Category:	\$ 150.35
Amount:	\$500.00	Trans I/O:	\$ -

Why Funds Are Needed:

The City Clerk's office has a specialized copier lease due to the volume of activity in the office. Additional funds are needed to cover higher costs for FY'24.

Sean R. Reardon, Mayor:

Date:

5/2/2024

Ethan R. Manning, Auditor:

Date:

5/8/2024

City Council Action:



CITY OF NEWBURYPORT FY 2024

RECEIVED
CITY CLERK'S OFFICE
NEWBURYPORT, MA

TRANSFER/APPROPRIATION REQUEST

APR 13 2024 P 3:45

Department: Mayor's Office
Submitted by: Sean R. Reardon, Mayor **Date Submitted:** 5/13/2024

Transfer From:

Account Name:	<u>Multiple - See attached</u>	Balance:	<u>n/a</u>
Account Number:	<u>Multiple - See attached</u>	Category:	<u>n/a</u>
Amount:	<u>\$3,247,088.76</u>	Trans I/O:	<u>n/a</u>

Why Funds Are Available:

Funding from Free Cash, Retained Earnings, closed-out capital projects and other available funds. See attached detail.

Transfer To:

Account Name:	<u>FY'25 Special Purpose/Capital Projects</u>	Balance:	<u>n/a</u>
Account Number:	<u>Multiple - See attached</u>	Category:	<u>n/a</u>
Amount:	<u>\$3,247,088.76</u>	Trans I/O:	<u>n/a</u>

Why Funds Are Needed:

Funding for FY2025 capital and special purpose appropriations. See attached detail.

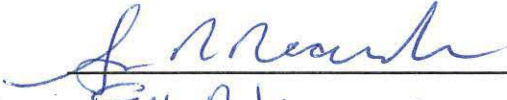
Sean R. Reardon, Mayor: 

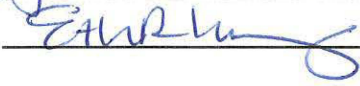
Ethan R. Manning, Auditor: 

City Council Action:

Date: 5/8/2024

Date: 5/8/2024

FY2025 Special Purpose and Capital Funding Recommendations (Submitted: May 13, 2024)

Project Listing with Funding Sources

CIP #	Pg. #	Department	Project / Source	Amount	Rationale
n/a	n/a	Finance	Stabilization Trust Fund <i>Free Cash</i>	250,000.00 <i>250,000.00</i>	An annual appropriation to the Stabilization Trust Fund is recommended. The current balance is \$4,559,220. This will bring the fund balance from 5.5% to 5.8% of the FY'24 budget maintaining the City's minimum target ratio of 5.0%.
n/a	n/a	Finance	Compensated Absences <i>Free Cash</i> <i>Paid Parking Fund (2739)</i>	300,000.00 <i>290,000.00</i> <i>10,000.00</i>	To pay contractual earned leave upon an eligible employee's retirement. This amount funds approximately 5 retirements that are anticipated for FY2025.
n/a	n/a	Finance	OPEB Trust Fund <i>Free Cash</i> <i>Water Retained Earnings</i> <i>Sewer Retained Earnings</i> <i>Harbor Retained Earnings</i>	100,000.00 <i>94,240.00</i> <i>3,330.00</i> <i>2,250.00</i> <i>180.00</i>	Recommend appropriation of \$100,000 split pro rata between funds based on share of OPEB liability.
n/a	n/a	Planning/ Development	Plum Island FEMA Buyouts <i>Free Cash</i> <i>Plum Island Hydrant Replacement (4005)</i>	395,027.60 <i>197,513.80</i> <i>197,513.80</i>	There is a request through FEMA's Hazard Mitigation Grant Program to fund the buyout of three homes on Plum Island. The City needs to be prepared to fund the non-federal match (\$395,027.60) should the grant be awarded. If any homeowners opt out of this program, remaining funds would be returned to the respective funding sources.
IT02	18	Information Technology	City Building Security Upgrades <i>Free Cash</i> <i>RRFA Insurance Proceeds (2741)</i> <i>Harbor Retained Earnings</i> <i>Paid Parking Fund (2739)</i> <i>Senior/Comm Center Maint Revolving (2841)</i> <i>Senior/Community Center Project (4505)</i>	246,848.00 <i>101,650.94</i> <i>51,864.06</i> <i>25,305.00</i> <i>25,046.00</i> <i>29,981.11</i> <i>13,000.89</i>	The project integrates access controls and security cameras at the following sites onto the Verkada platform, which is currently being implemented by the school district: Police Station (\$80,482), Harbormaster Office (\$25,305), Library (\$13,024), Parking Garage (\$25,046), Senior/Community Center (\$42,982) and City Hall (\$60,010).
FD01	22	Fire	Fire Headquarters Bathroom Renovation <i>Smart Growth 40R Incentives (2141)</i>	50,000.00 <i>50,000.00</i>	The single bathroom facility at headquarters, which includes a single shower, is in need of a remodel while we consider a longer-term plan to address the entire building.

CIP #	Pg. #	Department	Project / Source	Amount	Rationale
FD04	25	Fire	Replace/Update Radio Equipment & Shed	175,000.00	This is a combined request by the Fire, Police, and Public Services departments to replace outdated and non-compliant communication equipment at shared facilities located at Anna Jaques Hospital (AJH), March's Hill, and the Verizon Cell Tower on Storey Ave. The project would involve replacing the radio repeater receiving/transmission equipment and the dilapidated shed housing this equipment at the Rawson Ave site at AJH. The replacement shed would be climate-controlled to protect the sensitive equipment.
			<i>Free Cash</i>	<i>135,000.00</i>	
			<i>Water Retained Earnings</i>	<i>20,000.00</i>	
			<i>Sewer Retained Earnings</i>	<i>20,000.00</i>	
PD05	32	Police	Portable Radios <i>Smart Growth 40R Incentives (2141)</i>	50,000.00 <i>50,000.00</i>	The portable radios are 14 years old and are starting to break down. The portable radios are an important for communications and officer safety. This project will replace 40 radios that are used daily by the department.
HW01	36	DPS	Streets/Sidewalks (C/Y 2025) <i>RRFA Settlements (2745)</i>	185,823.16 <i>185,823.16</i>	Funds are available for appropriation in the receipts reserved for appropriation (RRFA) legal settlements account. \$150,000 of the remaining balance was from the High Street line painting settlement, therefore it is recommended that the full balance be earmarked for streets/sidewalks improvements planned for the 2025 construction season to decrease the amount planned for borrowing for that year.
HW06	41	DPS	City Hall Feasibility Study <i>Free Cash</i>	50,000.00 <i>50,000.00</i>	Conduct a feasibility study to improve the functionality of the building, better organize office spaces, improve wayfinding, upgrading of electrical, IT infrastructure and HVAC systems and from this study determine cost for the renovation of City Hall.
HW07	42	DPS	Downtown Lighting	220,000.00	Phase 3 of 4 of the downtown lighting LED replacement project. This project addresses approximately 98 lights at Market St, Green St & Brown Square. Newburyport's historic street lights have outlived their useful life and are quickly becoming an environmental hazard due to their 50-year-old ballasts.
			<i>Paid Parking Fund (2739)</i>	<i>100,000.00</i>	
			<i>Smart Growth 40R Incentives (2141)</i>	<i>70,000.00</i>	
			<i>Rev Wire Inspection Fees (2806)</i>	<i>50,000.00</i>	
HW08	43	DPS	Vehicles and Equipment (All DPS Divisions)	477,000.00	Purchase of new Trash Truck \$225,000 (Highway) and replacement of Bucket Truck \$180,000 (Highway/Fire), Ford Transit \$36,000 (Sewer) and Ventrac Mower \$36,000 (Parks)
			<i>Free Cash</i>	<i>441,000.00</i>	
			<i>Sewer Retained Earnings</i>	<i>36,000.00</i>	

CIP #	Pg. #	Department	Project / Source	Amount	Rationale
SW07	65	DPS	Waste Water Treatment Facility (WWTF) - Relocation <i>Sewer Retained Earnings</i>	150,000.00 <i>150,000.00</i>	Climate change has led to rising river levels, causing recurrent flooding at the WWTF. Projection models indicate that the treatment facility lies within a future flood-prone area, necessitating exploration of relocation options. A feasibility study will identify potential locations within the city for a new facility, evaluating wetlands, operational logistics, and hydrological factors to guide future property acquisition.
SW08	66	DPS	WWTF Priority Equipment Replacement Program <i>Sewer Retained Earnings</i>	355,000.00 <i>355,000.00</i>	Operating a 24/7 facility is complex and costly, requiring constant repairs and equipment replacements. Recent cost increases have left critical equipment in need of replacement beyond the budget's limits. We recommend funding four priority projects in FY'25, totaling \$355,000, to avoid costly shutdowns and protect public health and safety.
SC02	75	Schools	NHS Telephone System Replacement <i>Smart Growth 40R Incentives (2141)</i> <i>Free Cash</i>	125,000.00 <i>82,000.00</i> <i>43,000.00</i>	Finding parts to repair the high school's 20-year-old phone system has become increasingly difficult, and the system is not e911 compliant as required by law. Additionally, the FCC no longer requires providers to maintain analog phone systems, potentially making the system inoperable in the future. Replacing the system will require new wiring, networking, VoIP phones, and an estimated \$25,000 allowance for wiring.
SC05	78	Schools	Bresnahan MDF AC Upgrade <i>Free Cash</i>	50,000.00 <i>50,000.00</i>	The Main Distribution Frame closet at Bresnahan consistently operates at temperatures around or exceeding 80 degrees, putting the technology equipment at risk. Over the ten years since the building's construction, additional heat-generating equipment has been added, exceeding the design capacity of the current AC unit. This includes city-owned equipment serving as an off-site instance of the city's virtual server infrastructure, installed due to a lack of rack space, alongside some old equipment that remains in place.
SC06	79	Schools	Pick-Up Truck with Utility Body <i>Free Cash</i>	67,390.00 <i>67,390.00</i>	Purchase of Ford F250 4x4 pickup with utility body for maintenance technician, replacing deteriorating 2010 Ford Econoline van. Van's frame is severely rusted, posing inspection uncertainty. New truck, without plow initially, can accommodate future plow addition as current plow truck ages. Quote based on State Contract VEH110 for 2025 model year.
Total				3,247,088.76	

FY2025 Special Purpose and Capital Funding Recommendations (Submitted: May 13, 2024)

Overview of Funding Sources

Source	Current Balance	Appropriation Amount	Remaining Balance
Free Cash	2,420,777	1,719,795	700,982
Sewer Retained Earnings	1,700,973	563,250	1,137,723
Smart Growth 40R Incentives (2141)	252,000	252,000	0
Plum Island Hydrant Replacement (4005)	372,543	197,514	175,029
RRFA Settlements (2745)	185,823	185,823	0
Paid Parking Fund (2739)	1,057,052	135,046	922,006
RRFA Insurance Proceeds (2741)	51,864	51,864	0
Rev Wire Inspection Fees (2806)	121,762	50,000	71,762
Senior/Comm Center Maint Revolving (2841)	69,817	29,981	39,836
Harbor Retained Earnings	821,187	25,485	795,702
Water Retained Earnings	1,098,927	23,330	1,075,597
Senior/Community Center Project (4505)	13,001	13,001	0
Total Appropriation Amount:		3,247,089	

**APPOINTMENTS
FIRST READING**



CITY OF NEWBURYPORT

OFFICE OF THE MAYOR

SEAN R. REARDON, MAYOR

RECEIVED
CITY CLERK'S OFFICE
NEWBURYPORT, MA
2024 MAY -7 A 8:41

60 PLEASANT STREET - P.O. BOX 550

NEWBURYPORT, MA 01950

978-465-4413 PHONE

MAYOR@CITYOFNEWBURYPORT.COM

To: President and Members of the City Council

From: Sean R. Reardon, Mayor

Date: May 13, 2024

Subject: Appointment

I hereby appoint, subject to your approval, the following named individual as a member of the Newburyport Waterfront Trust. This term will expire on February 15, 2026.

Leslie Eckholdt
36 Warren Street
Newburyport, MA 01950

September 9, 2021

Mayor Donna Holaday
Donna Musumeci, Executive Assistant to the Mayor
City of Newburyport
60 Pleasant Street
Newburyport, MA 01950

Dear Donna's,

As you likely have heard, I am interested in applying for an open seat on the Waterfront Trust Board.

My reasons are several. As was the case when I was on the Newburyport Redevelopment Authority, I am very interested in the creation of a great waterfront park for the City. While working in Boston and from my travels, I saw how important and effective fine parks were to the quality of life in the city. I would like to be of assistance with the future development of our remarkable park.

While on the NRA, I served as a liaison to the Waterfront Trust in order to keep the NRA informed of its work. Because of this, I was able to know the Waterfront Trust's members and staff and the excellent work they were doing. I would bring this background experience to the Board.

I served as treasurer to the NRA and could bring that skill set to the Waterfront Trust.

Being a member of the Waterfront Trust would be an opportunity to be of service to this community, which has been such a pleasure to live in. I enjoyed serving on the NRA and would welcome the continuance of this kind of work.

Thank you for your consideration of my application to the Waterfront Trust.

Sincerely,
Leslie Eckholdt

Leslie H. Eckholdt
36 Warren St.
Newburyport, MA
978-465-6066
339-201-1546
leckholdt@comcast.net

Work Experience

- 1963 - 1965 Administrative assistant & librarian, Boston University,
Boston, MA
- 1965 - 1969 Academic advisor, University of MN, Mpls., MN
- 1969 - 1971 College counselor, Metropolitan State University, Mpls., MN
- 1971 - 1977 Reference librarian, American Community School, Beirut,
Lebanon and Haverhill Public Library, Haverhill, MA
- 1979 - 1988 Mortgage lending officer, consumer lending officer, branch
manager, Home Savings & Loan, First Federal Savings &
Loan, Norwest Bank (now Wells Fargo Bank), Mpls., MN
- 1989 - 1994 Broker's assistant and stock broker, Smith Barney Securities,
Prudential Securities, Mpls., MN
- 1995 - 2000 Retirement plans department manager, Colonial Mutual
Funds, Boston, MA
- 2000- 2007 Retirement plans specialist, MetLife Inc., Boston, MA
- 2007 - Retired

Education and Background

Brown University, BA degree 1963
Art history major studied with Professor William H. Jordy, a leading
American architectural historian.

University of MN, College of Education MA degree 1969
College counseling program.

Series 7, 63, 65 Licenses and CFA Level 1

Extracurricular interests: Historic architecture and preservation, current events, politics and history, travel, gardening, art & art history. Founding member of Roof Overhead. Newburyport Redevelopment Authority 2014-2019



CITY OF NEWBURYPORT
OFFICE OF THE MAYOR
SEAN R. REARDON, MAYOR

RECEIVED
CITY CLERK'S OFFICE
NEWBURYPORT, MA
2024 MAY -7 A 8:41

60 PLEASANT STREET - P.O. BOX 550
NEWBURYPORT, MA 01950
978-465-4413 PHONE
MAYOR@CITYOFNEWBURYPORT.COM

To: President and Members of the City Council
From: Sean R. Reardon, Mayor
Date: May 13, 2024
Subject: Appointment

I hereby appoint, subject to your approval, the following named individual as a member of the Newburyport Waterfront Trust. This term will expire on July 1, 2029.

Curtis Davis
6 Market Street
Newburyport, MA 01950

CURTIS DAVIS
6 Market Street
Newburyport, MA 01950
(814)243-2505
Cudavis63187@gmail.com

OBJECTIVE

To work for a progressive company in a position that promotes employee and/or community interaction and communication to accomplish win-win situations.

EDUCATION

Master's Degree in Public administration: Certificate of Concentration in City Management, University of Pittsburgh, 1988.

Graduate Work: 24 credits for state certification in teaching, Indiana University of Pennsylvania, 1967 to 1973. National Science Foundation Grant for 6 graduate credits in Psychology at Beaver College, Glenside, PA.

Bachelor of Science in Education: Social Sciences, Indiana University of Pennsylvania, 1967.

WORK EXPERIENCE

Grant Writer/Administrator: Alternative Community Resource Programs, 2010 to Present

- Write grants and make contacts for funding sources for all programs.
- Certified Lead Facilitator for School Wide Positive Behavior Support Systems in Pennsylvania schools.

Presenter & Trainer: Diversity & Inclusion with Haselrig Group, Ethics in Mental Health, Management & Leadership Training, Grant Writing.

City Manager: City of Johnstown, 2005 through 2009

- Responsible for daily operations of municipality of approximately 23,000 population
- Responsible for the hiring, firing, training and disciplining of 200 employees including Police, Fire, Public Works, Finance, Codes enforcement, Community and Economic Development as well as other areas.
- Prepare and monitor a 30 Million dollar budget.
- Negotiated with four unions in finalizing seven contracts over a four year period.
- Provide monthly reports to a nine member council of elected officials.

Assistant City Manager: City of Johnstown, 2002 to 2005

- Responsible for Bureau of Parking and conducting an analysis of parking revenues and enforcement.
- Developed and wrote a **Personnel Manual** for all city employees.
- First level of discipline process for all employees.
- Responsible for all public records.

Safe and Drug Free Schools Coordinator/Director of Student Assistance Programs:

Greater Johnstown School District, 1989 to 2002

- Responsible for writing and monitoring Safe and Drug Free Schools Grants.
- Trained and implemented Student Assistance Teams for the high school, middle school and elementary schools.
- Developed a Student Leadership Program that trained high school students to take middle school students to leadership and team building camps during the school year and developing mentoring relationships.
- Responsible for identifying and referring over 200 students annually for drug, alcohol or mental health issues to proper counseling agencies.

Instructor: Greater Johnstown School District, 1967 to 2002

- Wrote , implemented and taught Psychology from 1979 to 2002.
- Wrote, implemented and taught al local history course titled "Our Town" from 1976 to 1995.

- Taught a variety of courses in Economics, Political Science and Current Events.

Wrestling Coach: Greater Johnstown High School, 1968 to 1971.

University of Pittsburgh at Johnstown, 1973 to 1977.

Wrestling Official: Pennsylvania Interscholastic Athletic Association (PIAA) and National Collegiate Athletic Association (NCAA), 1969 to 1999

- Officiated the Pennsylvania State Championships as well as numerous regional and district championships. Officiated the NCAA Division II and Division III championships as well as numerous NCAA qualifiers.

OTHER PROFESSIONAL EXPERIENCES

Chief Negotiator for Stonycreek Township with Police Department, 1985

Negotiations Training I, II, III, and IV at P.S.E.A. Seminars, 1989, 90, 91 and 92.

Chief Negotiator for Greater Johnstown Education Association, 1992

Chief Negotiator for Greater Johnstown Education Association for Timed Mediation, 1996

Chief Negotiator for Southmont Borough with A.F.S.C.M.E., 1997.

Trainer and Coordinator of Peer Mediation Program Greater Johnstown School District, 1996 to 2002.

Resiliency Trainer and Co-Facilitator with Dr. Gerald Zahorchak for Greater Johnstown School District, 1996 to 2002 and Presenter at the Pennsylvania State Student Assistance Conference.

Local consultant to President Clinton's development of the Violent Crime Control and Law Enforcement Act of 1994.

International City/County Management Association Member (ICMA): 1984 to 1987 and 2002 to 2010. P

Local Government Academy Member 2008-2009. "Pillars of Good Government Program" "Powers and Duties" and "Ethics" Teams to promote excellence in local government. The program is to develop principles,

Pennsylvania Association of Positive Behavior Support Programs (PAPBIS) Lead Facilitator: 2009 to present. State certified Lead Facilitator to train and work with any Pennsylvania School District in implementing an evidence based School Wide Positive Behavior and Intervention Support Program.

Center for Health Promotion and Disease Prevention: 2013. Presenter and panelist for community forum on "School and Community Safety; Lessons Learned from the Sandy Hook Tragedy.

COMMUNITY ACTIVITIES

Chairman Johnstown Planning Commission: 2018 to 2023.

Penn Highlands Community College: Grant Writing Workshops, 2014

Johnstown Area Regional Industries: Advisory Board Member, 2005 to 2009

Southmont Borough Council member: 1996 to 1999.

Stonycreek Township Commissioner: (Cambria County), 1981 to 1989

President of Cambria County Community Action Council Board of Directors: 1992 to 1996

Charter Commission and Transition Committee Member: City of Johnstown, 1972 to 1973

REFERENCES

Dr. Donato Zucco, Retired V.P. Crown American, Inc, Mayor of Johnstown 1998 to 2006. Cell phone (814) 322-2959

Dr. Gerald Zahorchak, Former Pennsylvania Secretary of Education, currently Superintendent Greater Johnstown School District. Cell phone (814) 242-9553

Dr. Albert Reynolds, Former City Council member, retired CEO of Hiram G. Andrews Center. Cell phone # (814) 244-2232.



CITY OF NEWBURYPORT
OFFICE OF THE MAYOR
SEAN R. REARDON, MAYOR

RECEIVED
CITY CLERK'S OFFICE
NEWBURYPORT, MA
2024 MAY -7 A 8:41

60 PLEASANT STREET - P.O. BOX 550
NEWBURYPORT, MA 01950
978-465-4413 PHONE
MAYOR@CITYOFNEWBURYPORT.COM

To: President and Members of the City Council
From: Sean R. Reardon, Mayor
Date: May 13, 2024
Subject: Appointment

I hereby appoint, subject to your approval, the following named individual as a member of the Newburyport Waterfront Trust. This term will expire on July 1, 2029.

Curtis Davis
6 Market Street
Newburyport, MA 01950

CURTIS DAVIS
6 Market Street
Newburyport, MA 01950
(814)243-2505
Cudavis63187@gmail.com

OBJECTIVE

To work for a progressive company in a position that promotes employee and/or community interaction and communication to accomplish win-win situations.

EDUCATION

Master's Degree in Public administration: Certificate of Concentration in City Management, University of Pittsburgh, 1988.

Graduate Work: 24 credits for state certification in teaching, Indiana University of Pennsylvania, 1967 to 1973. National Science Foundation Grant for 6 graduate credits in Psychology at Beaver College, Glenside, PA.

Bachelor of Science in Education: Social Sciences, Indiana University of Pennsylvania, 1967.

WORK EXPERIENCE

Grant Writer/Administrator: Alternative Community Resource Programs, 2010 to Present

- Write grants and make contacts for funding sources for all programs.
- Certified Lead Facilitator for School Wide Positive Behavior Support Systems in Pennsylvania schools.

Presenter & Trainer: Diversity & Inclusion with Haselrig Group, Ethics in Mental Health, Management & Leadership Training, Grant Writing.

City Manager: City of Johnstown, 2005 through 2009

- Responsible for daily operations of municipality of approximately 23,000 population
- Responsible for the hiring, firing, training and disciplining of 200 employees including Police, Fire, Public Works, Finance, Codes enforcement, Community and Economic Development as well as other areas.
- Prepare and monitor a 30 Million dollar budget.
- Negotiated with four unions in finalizing seven contracts over a four year period.
- Provide monthly reports to a nine member council of elected officials.

Assistant City Manager: City of Johnstown, 2002 to 2005

- Responsible for Bureau of Parking and conducting an analysis of parking revenues and enforcement.
- Developed and wrote a **Personnel Manual** for all city employees.
- First level of discipline process for all employees.
- Responsible for all public records.

Safe and Drug Free Schools Coordinator/Director of Student Assistance Programs:

Greater Johnstown School District, 1989 to 2002

- Responsible for writing and monitoring Safe and Drug Free Schools Grants.
- Trained and implemented Student Assistance Teams for the high school, middle school and elementary schools.
- Developed a Student Leadership Program that trained high school students to take middle school students to leadership and team building camps during the school year and developing mentoring relationships.
- Responsible for identifying and referring over 200 students annually for drug, alcohol or mental health issues to proper counseling agencies.

Instructor: Greater Johnstown School District, 1967 to 2002

- Wrote , implemented and taught Psychology from 1979 to 2002.
- Wrote, implemented and taught al local history course titled "Our Town" from 1976 to 1995.

- Taught a variety of courses in Economics, Political Science and Current Events.

Wrestling Coach: Greater Johnstown High School, 1968 to 1971.

University of Pittsburgh at Johnstown, 1973 to 1977.

Wrestling Official: Pennsylvania Interscholastic Athletic Association (PIAA) and National Collegiate Athletic Association (NCAA), 1969 to 1999

- Officiated the Pennsylvania State Championships as well as numerous regional and district championships. Officiated the NCAA Division II and Division III championships as well as numerous NCAA qualifiers.

OTHER PROFESSIONAL EXPERIENCES

Chief Negotiator for Stonycreek Township with Police Department, 1985

Negotiations Training I, II, III, and IV at P.S.E.A. Seminars, 1989, 90, 91 and 92.

Chief Negotiator for Greater Johnstown Education Association, 1992

Chief Negotiator for Greater Johnstown Education Association for Timed Mediation, 1996

Chief Negotiator for Southmont Borough with A.F.S.C.M.E., 1997.

Trainer and Coordinator of Peer Mediation Program Greater Johnstown School District, 1996 to 2002.

Resiliency Trainer and Co-Facilitator with Dr. Gerald Zahorchak for Greater Johnstown School District, 1996 to 2002 and Presenter at the Pennsylvania State Student Assistance Conference.

Local consultant to President Clinton's development of the Violent Crime Control and Law Enforcement Act of 1994.

International City/County Management Association Member (ICMA): 1984 to 1987 and 2002 to 2010. P

Local Government Academy Member 2008-2009. "Pillars of Good Government Program" "Powers and Duties" and "Ethics" Teams to promote excellence in local government. The program is to develop principles,

Pennsylvania Association of Positive Behavior Support Programs (PAPBIS) Lead Facilitator: 2009 to present. State certified Lead Facilitator to train and work with any Pennsylvania School District in implementing an evidence based School Wide Positive Behavior and Intervention Support Program.

Center for Health Promotion and Disease Prevention: 2013. Presenter and panelist for community forum on "School and Community Safety; Lessons Learned from the Sandy Hook Tragedy.

COMMUNITY ACTIVITIES

Chairman Johnstown Planning Commission: 2018 to 2023.

Penn Highlands Community College: Grant Writing Workshops, 2014

Johnstown Area Regional Industries: Advisory Board Member, 2005 to 2009

Southmont Borough Council member: 1996 to 1999.

Stonycreek Township Commissioner :(Cambria County), 1981 to 1989

President of Cambria County Community Action Council Board of Directors: 1992 to 1996

Charter Commission and Transition Committee Member: City of Johnstown, 1972 to 1973

REFERENCES

Dr. Donato Zucco, Retired V.P. Crown American, Inc, Mayor of Johnstown 1998 to 2006. Cell phone (814) 322-2959

Dr. Gerald Zahorchak, Former Pennsylvania Secretary of Education, currently Superintendent Greater Johnstown School District. Cell phone (814) 242-9553

Dr. Albert Reynolds, Former City Council member, retired CEO of Hiram G. Andrews Center. Cell phone # (814) 244-2232.

END OF CONSENT AGENDA

BEGINNING OF REGULAR AGENDA

ORDERS



CITY OF NEWBURYPORT
GIFT ACCEPTANCE FORM

Ordered, that, the City of Newburyport accepts the following gift in accordance with M.G.L. Chapter 44, Section 53A:

Date of Gift:	5/2/2024	
City Department:	DPS – Parks Division	
Staff Contact:	Michael Hennessey, Tree Warden	
<i>Gift Overview</i>		
Gift Type:	In-Kind	
Donor:	Saltbox Financial	
Purpose:	Four (4) red oak trees in front of the Bresnahan School. See attached.	
Gift Amount:	\$1,810.00	
<i>For Office Use Only</i>		
City Council Packet Date:	5/13/2024	
Emergency Measure?	<input type="checkbox"/> Yes	<input checked="" type="checkbox"/> No

Councillor Sharif I. Zeid

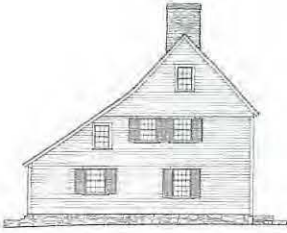

— SOLID. ENDURING. —

Saltbox Financial

17 Russia Street
Newburyport, MA 01950
(978) 255-2812

RECEIVED
CITY CLERK'S OFFICE
NEWBURYPORT, MA

2024 MAY -1 P 3:35

Newburyport City Council
Ed Cameron, President
Newburyport, MA 01950

1 May 2024

Re: In Kind Tree Donation for Bresnahan School Parking Lot

For several years I have been working on replacing dead trees in the Bresnahan parking lot. I have been coordinating the ongoing plan with Steve Bergholm, and we have made some great gains. The effort continues, and I anticipate at least three more growing seasons to finish.

Please accept this in-kind donation for 4 red oak trees to be planted in the front Bresnahan parking lot. (Kaknes Landscape Inv #36490 for \$1810.00) These red oaks are replacing 4 dead trees from the original planting. The original trees were planted in very poor soil. For the new trees, the holes have been pre dug, and heavily amended with good soil and organic matter. All new trees will be bagged and watered for at least two years.

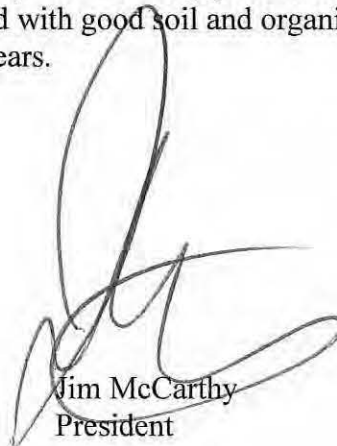

Jim McCarthy
President

Kaknes Landscape & Patio Supply

109 Rabbit Rd
Salisbury, MA 01952

www.kakneslandscape.com

Invoice

Phone #	Date	Invoice #
978 462 5348	5/1/2024	36490

Bill To		
City Of Newburyport 978 992 8093		
P.O. #	Terms	Ship
	Net 30	5/1/2024

Ship To	
senior center dr 978 417 9373 331 high st	
	Project

Quantity	Description	U/M	Base Rate	Price Each	Amount
4	QUERCUS RUBRA 2.5"	ea	611.9048	390.00	1,560.00
1	FLAT BED DELIVERY TO NEWBURYPORT		125.00	250.00	250.00

PAID W FULL
CR 7306
S.H. Box Financial

	Total	\$1,810.00
	Payments/Credits	\$0.00
	Balance Due	\$1,810.00

**CITY OF NEWBURYPORT
GIFT ACCEPTANCE FORM**

Ordered, that, the City of Newburyport accepts the following gift in accordance with M.G.L. Chapter 44, Section 53A:

Date of Gift:	5/1/2024	
City Department:	City Clerk	
Staff Contact:	Richard B. Jones	
<i>Gift Overview</i>		
Gift Type:	In-Kind	
Donor:	JoDee Doyle	
Purpose:	Art Work for the Clerk's Office	
Gift Amount:	\$5,000.00	
<i>For Office Use Only</i>		
City Council Packet Date:	5/13/2024	
Emergency Measure?	<input type="checkbox"/> Yes	<input checked="" type="checkbox"/> No

Councillor Sharif I. Zeid

The Marriage Contract

by
Norman Rockwell

Certificate of Authenticity

The work of art described and pictured on this certificate has been lithographed directly from the original painting in a limited edition of 2500 copies. This information is guaranteed as represented herein. No other copies exist and all original plates used to produce this series have been destroyed. The Norman Rockwell signature has been reproduced. Year of Publication 1979.

This is to certify that this is Print No. 705 of 2500.





CITY OF NEWBURYPORT



IN CITY COUNCIL

ORDERED:

May 13, 2024

THAT, the City of Newburyport raise and appropriate in the General Fund a sum of \$ _____ as the operating budget for Fiscal Year 2025 (July 1, 2024 to June 30, 2025), of which \$ _____ is appropriated to the School Department.

FURTHER THAT, to support said appropriations in the General Fund, the following sums shall be appropriated from other available funds:

Downtown Paid Parking Fund	\$ _____
Recreational Revolving Fund	\$ _____
Waterfront Parking Fund	\$ _____
Water Enterprise Fund	\$ _____
Sewer Enterprise Fund	\$ _____
Harbormaster Enterprise Fund	\$ _____

FURTHER THAT, the City of Newburyport raise and appropriate the following sums in the enterprise funds as the respective operating budget of each fund for Fiscal Year 2025:

Water Enterprise Fund	\$ _____
Sewer Enterprise Fund	\$ _____
Harbormaster Enterprise Fund	\$ _____

The appropriations above represent the annual budget for Fiscal Year 2025 as submitted by Mayor Reardon on May 13, 2024, as approved by the City Council with any amendments so voted.

Edward C. Cameron Jr., Council President

Afroz K. Khan, Councillor At-Large

Constance Preston, Councillor At-Large

Heather L. Shand, Councillor At-Large

Mark R. Wright, Councillor At-Large

Sharif I. Zeid, Ward 1 Councillor

Jennie L. Donahue, Ward 2 Councillor

Heath Granas, Ward 3 Councillor

Benjamin Harman, Ward 4 Councillor

James J. McCauley, Ward 5 Councillor

Byron J. Lane, Ward 6 Councillor

CITY OF NEWBURYPORT



IN CITY COUNCIL

ORDERED:

May 13, 2024

THAT, the City Council of the City of Newburyport adopts the FY2025-2029 Capital Improvement Program, as submitted by Mayor Reardon on May 13, 2024 with any amendments so voted.

Councillor Sharif I. Zeid

CITY OF NEWBURYPORT



IN CITY COUNCIL

ORDERED:

May 13, 2024

An Order to Allow a Waiver for an Asphalt Sidewalk on Willow Ave and Moseley Ave

Be it ordained by the City Council of the City of Newburyport as follows:

Chapter 12	Streets, Sidewalks and Other Public Places
Article III	Sidewalks
Section 54	Street, way or grounds specification
Subsection (b)	Sidewalk material

Pursuant to Section 12-54(b) which states as follows:

Exception: Asphalt may be used as an alternative material anywhere in the City upon obtaining a waiver granted by City Council Order.

The City Council of the City of Newburyport hereby grants a waiver to use asphalt as an alternative material for the sidewalks located on Willow Avenue and on Moseley Avenue.

Councillor Benjamin J. Harman

Councillor Byron J. Lane

ORDINANCES

CITY OF NEWBURYPORT



IN CITY COUNCIL

ORDERED:

March 11, 2024

AN ORDINANCE TO AMEND CHAPTER 5 BUILDINGS AND BUILDING REGULATIONS

CHAPTER 5 **BUILDINGS AND BUILDING REGULATIONS**
ARTICLE III **BUILDING CONSTRUCTION STANDARDS**
SEC. 5 – 65 **~~STRETCH~~ SPECIALIZED ENERGY CODE**

THAT the City Council of the City of Newburyport hereby amends Chapter 5 Buildings and Building Regulations, Article III Building Construction Standards by amending Section 5-65 to the City of Newburyport Code of Ordinances as follows, with deletions ~~double-stricken through~~ **and in bold**, and additions double-underlined and in bold:

~~5-65-1. Adoption. The City of Newburyport has adopted the provisions of 780 CMR 120.AA (i.e., Appendix 120.AA of the State Building Code or the "Stretch Energy Code"), as may be amended from time to time, in place of the provisions set forth under 780 CMR 13.00, 34.00, 61.00 and 93.00.~~

~~5-65-2. Purpose. The purpose of the Stretch Energy Code shall be to provide the city with a more energy efficient alternative to the base energy code otherwise set forth under the State Building Code.~~

5-65.1 Purpose

The purpose of the Specialized Energy code 225 CMR 22.00 and 23.00 including Appendices RC and CC, also referred to as the Specialized Energy Code is to provide a more energy efficient and low greenhouse gas emissions alternative to the Stretch Energy Code or the baseline Massachusetts Energy Code, applicable to the relevant sections of the building code for both new construction and existing buildings with the goal of achieving net Zero greenhouse gas emissions from the buildings sector no later than 2050. § _____



CITY OF NEWBURYPORT SUSTAINABILITY OFFICE

NEWBURYPORT CITY HALL

60 PLEASANT STREET
TEL: 978-499-0413

NEWBURYPORT, MA 01950

MEMORANDUM

TO: City Council President Edward Cameron and Members

FROM: Molly M. Ettenborough
Sustainability Manager
Michael Strauss
Chairman, Energy Advisory Committee

CC: Sean R. Reardon, Mayor
Andrew Levine, Chief of Staff
Greg Earls, Building Commissioner
Andrew Port, Director of Planning and Development

RE: Specialized Opt-In Stretch Code

Federal, state, and municipal governments have all made commitments to become net zero. In general terms that means that all energy use for building heating and cooling, electric plug loads, and transportation, will not add to greenhouse gas emissions in the atmosphere. The general plan from the federal and state government is to convert all energy use to electricity and green up the electric supply. Much of the work converting to electricity is at the local level, while converting the grid to renewable and non-greenhouse gas emitting sources is up to the state and federal governments. Currently, the ISO New England electric supply is 52% non-carbon emitting power. The percentage will increase over time.

Buildings heating and cooling are responsible for roughly one third of all greenhouse emissions. It is an important step for building codes to require buildings to use electricity for their HVAC systems or make sure they are wired for conversion, as it is less expensive to do this initially than to completely retrofit a building later.

The Specialized Opt-in Stretch code provides a tool for municipalities to encourage construction of electric buildings while maintaining consumer choice. With the Specialized Opt-in Stretch code in place, cities may focus their efforts on converting older buildings safe in the knowledge that new buildings will be energy efficient and either electric or easily converted to it.

The Specialized Opt-in Stretch code only applies to new construction and additions over 1000 square feet. For these additions, it only applies to the new space. The code does not require the existing space to be upgraded. The Specialized Opt-in Stretch code does not apply to renovations if they conform to the original footprint.

There are two pathways to conform to the Specialized Opt-in Stretch code. The first is the all-electric pathway. If the building is built with all electric utilities: heating, cooling, hot water, clothes dryer, and cooking, then nothing additional needs to be done above the current building code in the City of Newburyport.

The one exception is large multifamily buildings over 12,000 square feet. They need to have slightly higher energy efficiency than the current building code. This means better insulation, doors, windows, and air management.

The second pathway is mixed fuel. If the builder chooses to use fossil fuels for any part of the energy use, then additional requirements kick in. All building classes must be prewired for electricity. This means there must be panel capacity to handle all electric utilities and there must be wiring in place to get the electricity to appropriate places in the house. In addition, all building classes must have solar panels to offset at least some of the greenhouse gas emissions of the fossil fuels used, unless there is shading making it unfeasible or if it is a large multifamily (>12,000 square feet) because they will likely have heating and cooling units on the roof. Finally, all building classes except small homes (<4,000 square feet) will need to be constructed to a higher energy efficiency.

This two-pathway approach makes it easy for builders to plan and understand the consequences of their building choices. It is also straight forward for local building departments to implement. The State of Massachusetts DOER has determined that the total cost of ownership is less for new all-electric homes than for mixed fuel costs when one factors in the savings from incentives for electric operation and the differential in energy costs.

ADDITIONAL INFORMATION RESOURCES RELATED TO ALL-ELECTRIC HOMES

[Text of warrant article 31 and motion](#)

[Slide deck used for webinars](#)

[Cost advantages of electric heat pumps \(slides\)](#)

1. Cost & practicality

[It's Time to Rewire America and Electrify Everything](#) (3 minute video)

[The largest city in the U.S. bans natural gas in new buildings](#) (NYC, 12/2021)

Electric heating & cooling

- [Air Source Heat Pump Buying Guide](#)
- [Cost comparison calculator on Efficiency Maine website](#)
- [The Economics of Electrifying Buildings](#)

Electric cooking

- [NYT article - "The Case for Induction Cooking"](#)
- [Blog post - Induction vs Electric Cooktop](#)
- [How the Fossil Fuel Industry Convinced Americans to Love Gas Stoves](#)

Electric water heaters

- [Your Guide to Heat Pump Water Heaters](#)

Financial incentives for heat pumps, water heaters, insulation, solar panels, EVs

- [Summary list with links](#)

Other information about sustainable living

- [LincolnGreenEnergy.org](#)

2. Connections to state-wide policy

The 2021 climate act (Next-Gen/Roadmap Act)

- [“What You Need To Know About The New Mass. Climate Law”](#)
- [MAPC summary](#)

Similar motions passed by other towns:

- [Acton](#) (articles 13 and 14)
- [Arlington](#) (motion described, with link to it)
- [Brookline](#) (article 21)
- [Concord](#) (article 31)
- [Lexington](#) (article 29)

Pending general home rule legislation: [H.2167](#) and [S.1333](#)

Net zero stretch code development

- [February 2022 DOER proposal](#)
- [Related state webpage](#)
- [Net Zero Building Alliance comprehensive comment letter](#)
-

3. The urgency of climate change

- [“In a World on Fire, Stop Burning Things”](#) (Bill McKibben in [The New Yorker](#), 3/18/22)
- [Deloitte Report: Inaction on Climate Change Could Cost the US Economy \\$14.5 Trillion by 2070](#)
- [Climate change: a threat to human wellbeing and health of the planet. Taking action now can secure our future](#) (2/28/22 press release from the Intergovernmental Panel on Climate Change (“IPCC”))

4. Interested in retrofitting?

- [View the Videos of the ‘Home Electrification Series: A Step-by-Step Guide to Switching off Fossil Fuels and Going Electric in Your Home’](#)
- See also items under “Cost & Practicality”, above

5-65.2 Definitions

- a. International Energy Conservation Code (IECC) – The International Energy Conservation Code (IECC) is a building energy code created by the International Code Council. It is a model code adopted by many state and municipal governments in the United States for the establishment of minimum design and construction requirements for energy efficiency, and is updated on a three-year cycle. The baseline energy conservation requirements of the MA State Building Code are the IECC with Massachusetts amendments, as approved by the Board of Building Regulations and Standards and published in state regulations as part of 780 CMR.
- b. Specialized Energy Code – Codified by the entirety of 225 CMR 22 and 23 including Appendices RC and CC, the Specialized Energy Code adds residential and commercial appendices to the Massachusetts Stretch Energy Code, based on amendments to the respective net-zero appendices of the International Energy Conservation Code (IECC) to incorporate the energy efficiency of the Stretch energy code and further reduce the climate impacts of buildings built to this code, with the goal of achieving net-zero greenhouse gas emissions from the buildings sector no later than 2050.
- c. Stretch Energy Code - Codified by the combination of 225 CMR 22 and 23¹, not including Appendices RC and CC, the Stretch Energy Code is a comprehensive set of amendments to the International Energy Conservation Code (IECC) seeking to achieve all lifecycle cost-effective energy efficiency in accordance with the Green Communities Act of 2008, as well as to reduce the climate impacts of buildings built to this code. The stretch energy code was previously codified in 780 CMR appendix 115.aa, prior to the passage of the 2021 Act Creating a Next-generation Roadmap for Massachusetts Climate Polity (2021 Climate Act).

5-65.3 Applicability

This energy code applies to residential and commercial buildings.

5-65.4 Specialized Code

The Specialized Code, as codified by the entirety of 225 CMR 22 and 23 including Appendices RC and CC, including any future editions, amendments, or modifications, is herein incorporated herewith.

¹ Note: The Stretch energy code was previously codified in 780CMR appendix 115.aa, prior to the passage of the 2021 Act Creating a Next-generation Roadmap for Massachusetts Climate Policy (2021 Climate Act). The 2021 Climate Act transferred authority for promulgation of the Stretch energy code to the Department of Energy Resources

The Specialized Code is enforceable by the inspector of buildings or building commissioner.

Councillor Afroz K. Khan

Councillor Edward C. Cameron, Jr.

In City Council March 11, 2024:

Motion to refer Planning & Development and COTW by Councillor McCauley, seconded by Councillor Harman. Roll call vote, 10 yes, 1 absent (Khan), motion passes.

In City Council April 8, 2024:

Motion to approve by Councillor Shand, seconded by Councillor Preston. Motion to move to a date certain, April 29, 2024 by Councillor McCauley, seconded by Councillor Harman. Roll call vote, 10 yes, 1 absent, motion passes.

In City Council April 29, 2024:

Motion to take ODNC00166 off the table by Councillor Shand, seconded by Councillor Khan. So voted. Motion to approve on 1st reading as amended in committee to include the language not to begin “until July 2025” by Councillor Shand, seconded by Councillor Khan. Roll call vote, 7 yes (Wright, Granas, Harman, Khan, Preston, Shand, and Cameron) 4 no (Zeid, Donahue, Lane, McCauley), motion passes.

MA Specialized Opt-In Code Presentation

Newburyport City Council Meeting - February 26, 2024

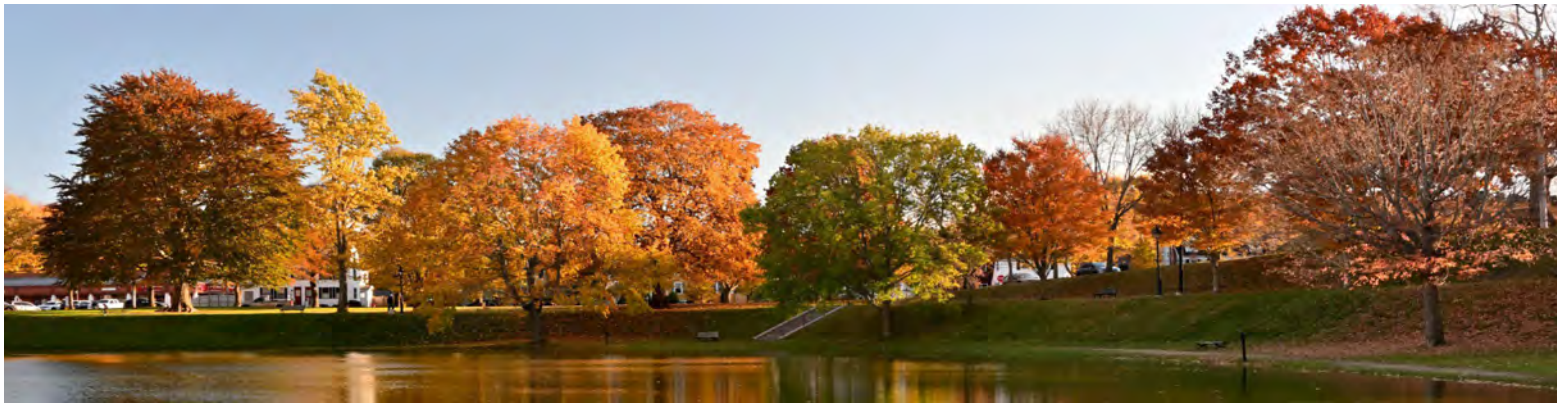

MA Energy Codes Updated in Jan 2023

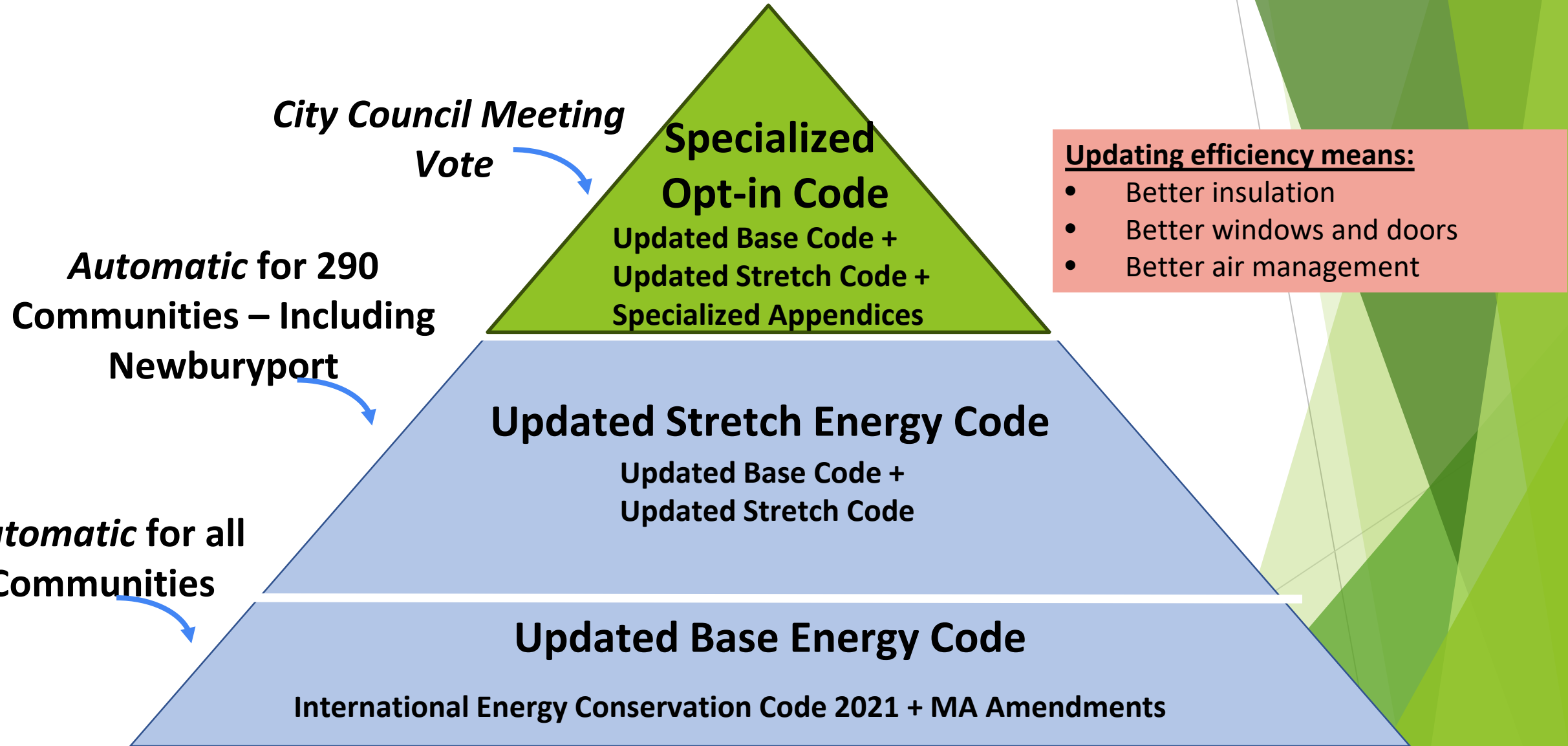

Why Specialized Opt-In Code

- ▶ Net Zero Commitments
 - ▶ Master Plan
 - ▶ Energy Road Map
 - ▶ C40 Agreement
- ▶ Buildings are ~1/3 of our carbon footprint
 - ▶ Need to reduce this
- ▶ Our Net Zero Plan
 - ▶ Go electric (our job)
 - ▶ Buildings
 - ▶ Transportation
 - ▶ Green up the grid (state and feds job)
- ▶ The electricity grid is decarbonizing
 - ▶ 52% non-carbon sources (ISO New England)
 - ▶ Increase over time
- ▶ Specialized Opt-In Code
 - ▶ New construction will be electric or electric ready
- ▶ 31 Communities in MA have adopted it so far

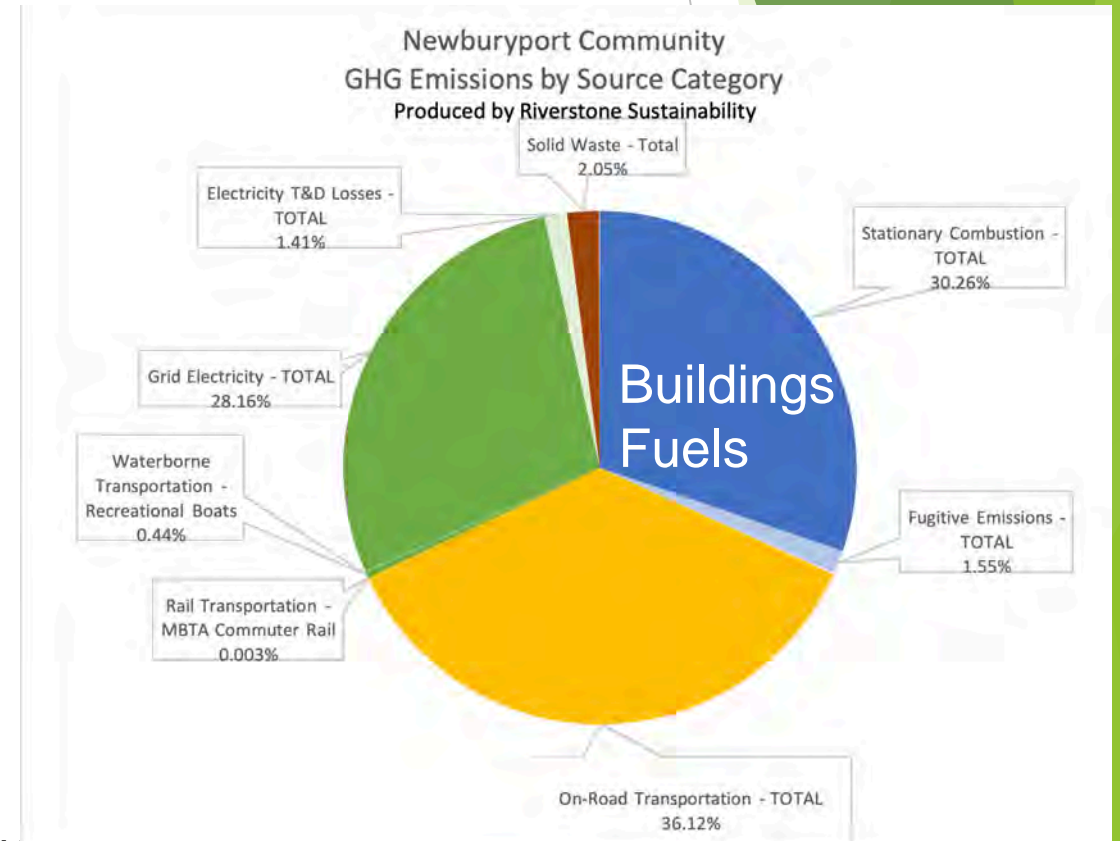

Adopting the Specialized Opt-In Code





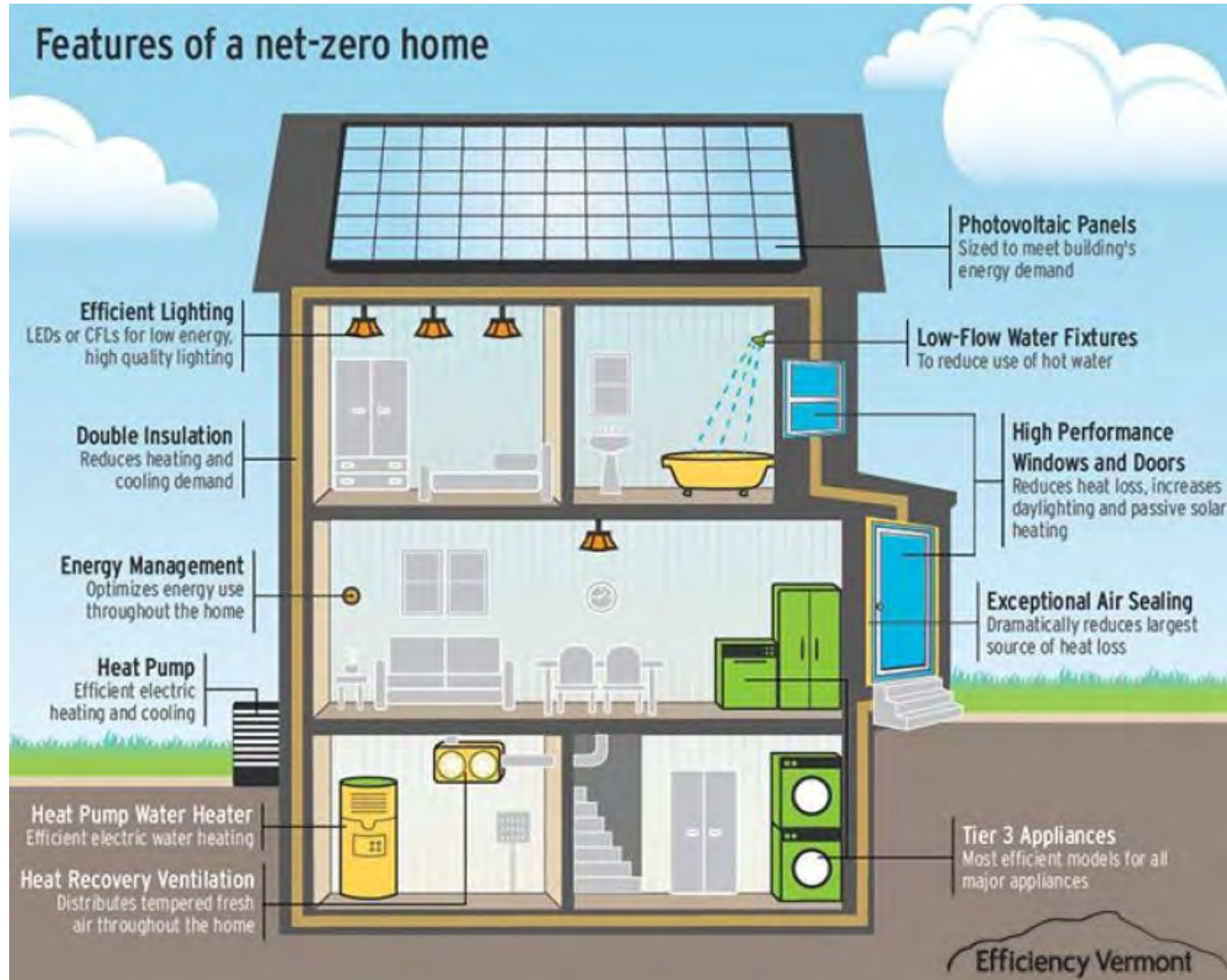

- Applies to **NEW** construction only.
 - Additions (>1000sqft) **NOT** original structure
 - Renovations are exempt
- **NOT** more efficient than stretch code, unless:
 - Large single family (>4000 sqft) & uses fossil fuels
 - Large multi-family (>12,000 sqft)
- Electric ready
 - Consumer choice in heating and cooling
 - Future proof: rewiring and panel capacity
- Encourages all-electric buildings:
 - Less \$ to build and operate
 - Healthier to live in
- New buildings: ready to meet MA climate goals
 - Per MA Dept. of Energy Resources

What Does an Energy Efficient Home Look Like?



2 Pathways for New Construction

	<u>All Electric</u> Heating, Cooling, Hot Water, Clothes Dryer, Stove	<u>Mixed Fuel</u> Some Fossil Fuels
Residential <4000sqft 	NO additional requirements over stretch code	Pre-wire for electric Solar unless shaded
Residential >4000sqft 	NO additional requirements over stretch code	Pre-wire for electric Solar Higher energy efficiency
Multifamily >12,000sqft 	Higher energy efficiency	Pre-wire for electric Higher energy efficiency
Commercial 	NO additional requirements over stretch code	Pre-wire for electric Solar panels Higher energy efficiency
Higher energy efficiency means better insulation, windows and doors, and air management		

Electric Buildings are Good for: Wallet, Comfort, Health, and Climate

- ▶ Lower initial and operating costs
 - ▶ Full cost of ownership: mortgage plus energy
 - ▶ MA DOER <https://www.mass.gov/doc/summary-of-stretch-code-study-energy-efficiency-analysis-feb-2022/download>
- ▶ Comfort
 - ▶ Quieter
 - ▶ Stable uniform temperatures
- ▶ Less Air Pollution = Improved Health Harvard School of Public Health 2017
 - ▶ In MA burning fuels in buildings:
 - ▶ 749 premature deaths
 - ▶ \$8.4 billion in additional health care costs
- ▶ Mitigates Climate Change
 - ▶ All-electric homes produce 31% fewer GHG emissions than mixed fuels homes.
 - ▶ Rocky Mountain Institute

Won't This Make Newburyport Undesirable

- ▶ Same concerns with
 - ▶ Bottle bill
 - ▶ Thin film plastic bag ban
 - ▶ Stretch code
- ▶ Newburyport property values continue to increase
 - ▶ It is the most desirable city in our region
 - ▶ Building and renovation costs lower!
 - ▶ Operating costs lower!
- ▶ The Specialized Opt-In Code means Newburyport homes are :
 - ▶ The most energy efficient possible
 - ▶ The most comfortable in all weather
 - ▶ Least expensive to operate
- ▶ Affordable housing
 - ▶ Affordable should be quality housing and comfortable housing

Better For the City

- ▶ Stretch code adoption (2010) enabled Green Community status
 - ▶ 7 grants, >\$1.2 million total
 - ▶ \$150,000/yr savings for streetlights alone
 - ▶ Almost all cities and towns are Green Communities: No longer an advantage
- ▶ New state program: Climate Leaders
 - ▶ Will require Specialized Opt-In code
 - ▶ Will open new funding opportunities for the city
- ▶ Minimal impact on city resources: Business as usual
 - ▶ Building Dept.
 - ▶ Planning Dept.
- ▶ The Specialized Opt-in code will become the base code over time
 - ▶ Might as well get the advantages of adopting it early
 - ▶ \$\$ for the city
 - ▶ Less expensive homes to build and operate
 - ▶ Homes that are better for the environment

Questions and Comments

Mike Strauss, Chair Energy Advisory Committee

Email: mstrauss@alum.mit.edu

Cell: 978-462-0102

Molly Ettenborough, Sustainability Manager

E-Mail: mettenborough@cityofnewburyport.com

Work: 978-499-0413

FAQs

- Does the Opt-In Specialized Code apply to existing structures?
 - **No.** Improvements to existing structures, depending on size, are regulated by the Updated Stretch Code and Base Code.
- Will the Opt-In-Specialized Code discourage the creation of affordable housing?
 - **No.** Incentives will continue to encourage affordable housing while the Opt-In Specialized Code delivers benefits for residents.
- Is it possible to install a gas cooktop?
 - **Yes.** This is permitted under the Mixed Fuel pathways.
- Why adopt the Opt-In Specialized Code?
 - **The #1 reason is that it requires pre-wiring**, avoiding costly retrofits down the road and expediting electrification.
- Why does the Opt-In Specialized Code permit fossil fuels?
 - **It preserves market choice** at a time when utility pricing is highly volatile and utility costs vary among MA communities.

The Electric Grid is Ready for the Specialized Code

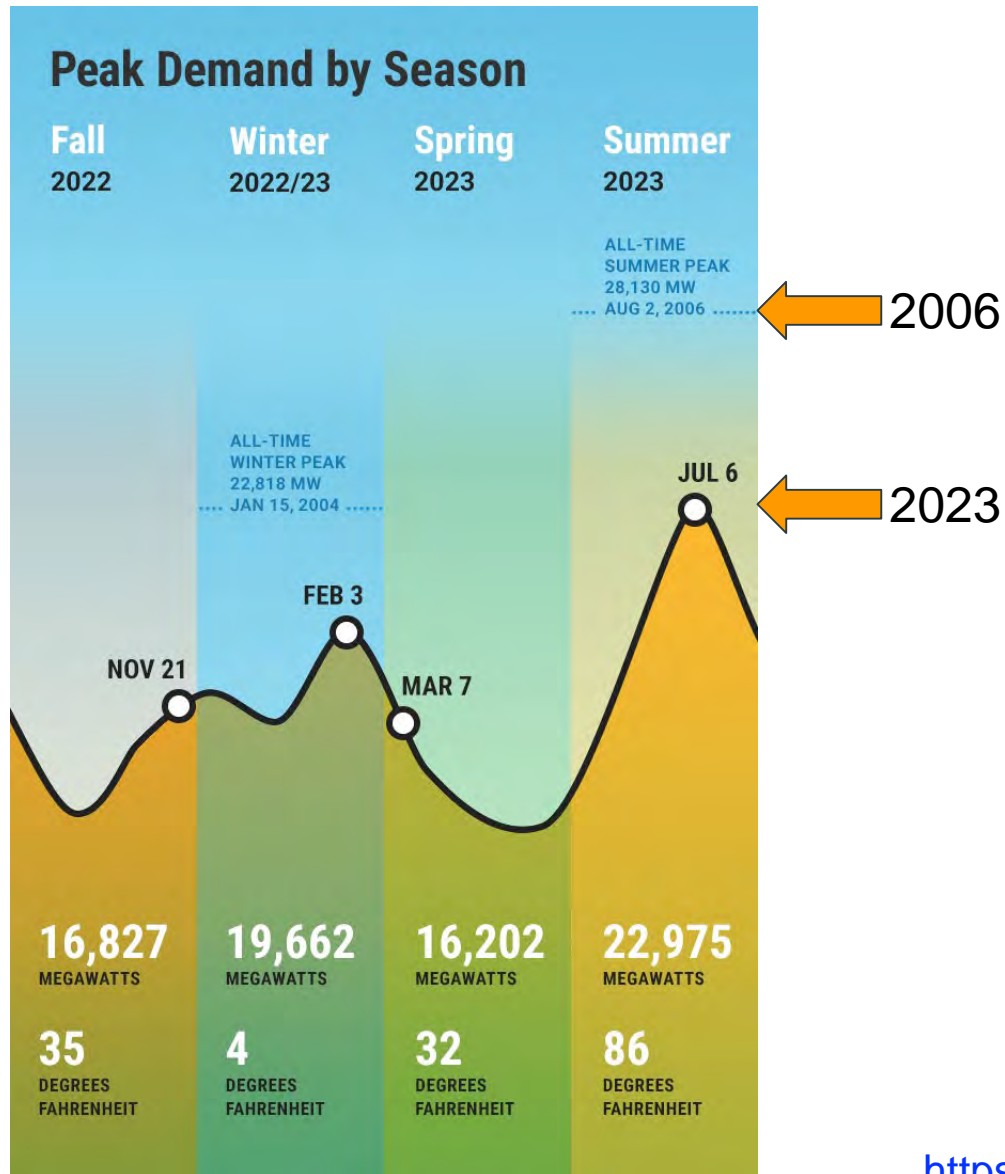

Current peak demand is 20% less than it was in 2006 due to energy efficiency and solar panel installations.

ISO New England's most recent 10 yr forecast:

- Summer peak demand is expected to grow by less than 2% annually through 2032
- Winter peak demand is expected to grow by 1-4% annually through 2032
- Capacity will continue to exceed peak demand

All-Electric Saves Money Versus Base Code!

- Electric: **less expensive** to install
- Electric: **less expensive** to operate: Mortgage & Energy

Building type	Incremental cost to build			Incremental cost to operate		
	Electric	Gas	Electricity edge	Electric	Gas	Electricity edge
Large 1-family	- \$20,062	+ \$3,183	\$23,245	- \$548	- \$302	\$246
Small 1-family	- \$28,597	+ \$7,907	\$36,504	- \$1,053	+ \$496	\$1,549
Townhouse	- \$11,938	+ \$802	\$12,740	- \$335	+ \$21	\$356
6-family	- \$15,690	+ \$2,277	\$17,967	- \$683	- \$14	\$669

From <https://www.mass.gov/doc/summary-of-stretch-code-study-energy-efficiency-analysis-feb-2022/download>
Summary pages 13-14, detail pages 16-32

Rapid Adoption of Opt-In Specialized Code: Communities Want to Protect Themselves

- ▶ The Opt-In Specialized Code, **designed to provide protections for communities** (although still not Fossil Fuel Free or Net-Zero, as it was mandated to be), has been passed in the following **31 communities** (as of 12.4.23), *many of those with unanimous or near-unanimous votes*, representing **25.6% of the State's population**, and far more in terms of building activity.
- ▶ About a dozen additional communities are expected to pass the Specialized Code later late Fall 2023 or Spring 2024, which would bring the total to **almost 30%** of the State's population. **The rapid adoption of the Specialized Code demonstrates that communities throughout MA are committed to adopting the BEST building codes that they are able to.**

List of Communities Who Have Opted-In to the Specialized Stretch Code (Updated 11/14/23)

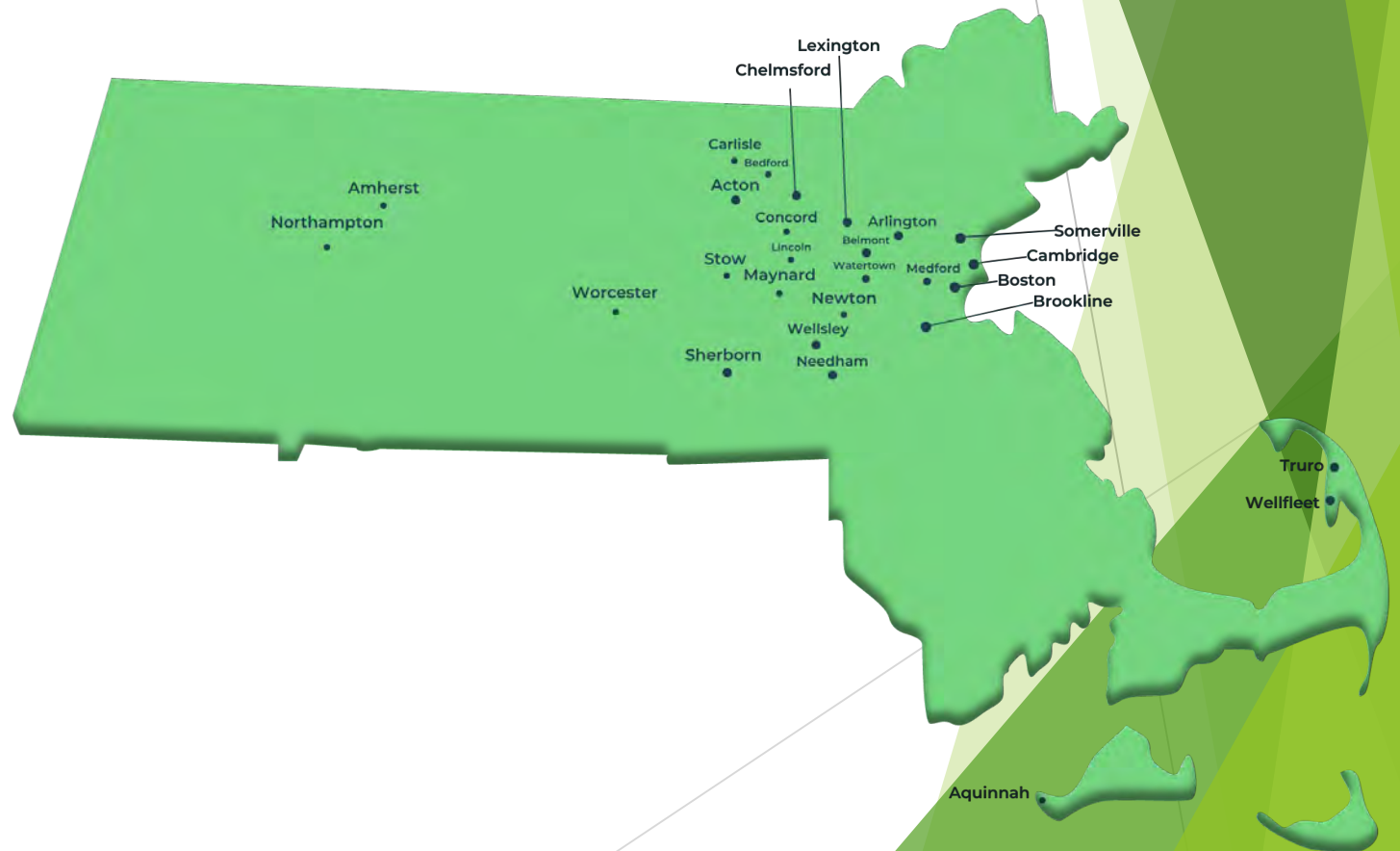



2023 Stretch Energy and Municipal Opt-In Specialized Building Code Frequently Asked Questions

1. What are the building energy code options for cities and towns in Massachusetts?

Massachusetts cities and towns now have 3 related choices of stringency of building energy code. These are the 'Base code' the 'Stretch code' and the 'Specialized code'. The minimum or 'base' energy code is the latest version of the national model code – the International Energy Conservation Code (IECC) with some amendments for Massachusetts. The base code is part of the building codes governed by the state Board of Building Regulations and Standards (BBRS). In 2023 the base code is being updated from the 2018 IECC to the 2021 IECC, and MA amendments adding wiring for electric vehicles and maintaining solar ready roof requirements.

2. What is the Stretch code?

The 'Stretch code' is a more energy efficient alternative to the base code. The 2023 update is the 3rd major update to the 2009 original Stretch code. The Stretch code increases the energy efficiency requirements for all new residential and commercial buildings, as well as for additions and renovations that require building permits. Municipalities started adopting the Stretch code in 2009; as of January 2023, 300 out of 351 Massachusetts cities and towns have adopted it. The Stretch code is now published and maintained by the Department of Energy Resources.

3. What is the Specialized code?

The Specialized code is required by statute ([MGL 25A Section 6](#)) to help achieve MA GHG emission limits and building sector_sub-limits set every five years from 2025 to 2050. As a result, all compliance pathways under the Specialized code are designed to ensure new construction that is consistent with a net-zero Massachusetts economy in 2050, primarily through a combination of energy efficiency, that it in turn enables reduced heating loads, and efficient electrification. Use of fossil fuels such as gas and propane or biomass is permitted but comes with additional requirements for on-site solar generation and pre-wiring for future electrification of any fossil fuel using equipment.

4. What is the anticipated cost of building under the Stretch energy code?

Designed and constructed in accordance to Stretch code standards, low-rise residential buildings built with all electric heating and cooling (via heat pumps) will typically cost less to build and operate than those built with fossil fuel heating. One reason for this is that heat pumps can be used for both heating and central air conditioning, whereas fossil fuel heated new homes typically require a separate air conditioning system.

DOER has commissioned studies to analyze the change in construction costs related to building to the Stretch code for several sizes and types of residences, and they generally indicate the construction and operating costs are lower under the Stretch code standards with fully electric heating and cooling via heat pumps. These case studies are available on DOER's website here:

<https://www.mass.gov/doc/residential-stretch-code-costs-and-benefits-case-studies/download>

Analysis of various types of common commercial buildings are also available on the DOER website,

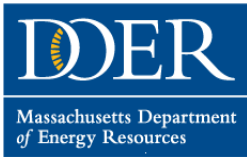

though these don't include an analysis of Mass Save or federal building incentives.

5. How do the base and Stretch codes differ?

The base energy code is currently based on amendments to the IECC2018 national model code but will update to the IECC2021 model code as part of a larger update to the building code as it moves from the 9th edition to the 10th edition. The timing is uncertain but expected at some point in 2023. **The base energy code in both the 9th and 10th editions provides two options** residential builders may use to meet energy efficiency requirements:

- **Prescriptive Method**, installing elements with specific energy efficiency levels (e.g., windows, or wall & roof insulation, furnace, etc.), or
- **Performance-based Method**, building to ensure the home performs to a specific level of efficiency, typically measured through a **HERS** (Home Energy Rating System) or **Passive House** analysis, including both of the design plans and the actual built home once construction is completed. The builder can decide how to design the house to reach the performance target.

The Stretch code requires that builders use the **performance-based method**. Measuring the home in this way brings in a 3rd party energy expert who verifies it is designed and built to perform as expected, which is **an important protection for the homeowner and for any future buyer**. Some builders in non-Stretch code communities voluntarily choose to use the performance-based method required by the Stretch code because it can often provide greater flexibility.

6. How is the Specialized code different from the Stretch code?

The Specialized code has accelerated adoption of more efficient HERS rating thresholds (HERS 42 and 45) and provides three paths for low rise residential compliance, including a zero-energy pathway (with solar PV). It also requires new homes over 4,000 sq ft to follow the all-electric or zero energy pathway. Solar PV is required for any new construction utilizing fossil fuels for heating. The Specialized code for multi-family housing 4 stories and above phases in Passive House standards by January 2024.

7. Where can I find and read more about the Stretch code and Specialized code?

The Stretch and Specialized codes are new regulations in [225 CMR 22.00](#) and [225 CMR 23.00](#). CMR 22.00 covers Residential low-rise construction and CMR 23.00 covers Commercial and all other construction (including most multi-family).

8. What building types does the Stretch energy code and Specialized code apply to?

The Stretch code applies to both residential and commercial new construction, as well as certain renovations and additions. The Specialized code applies only to new residential and commercial new construction.

9. What categories do multi-family residential buildings fall into?

Multi-family building with central heating and cooling are considered commercial buildings. Those that are townhouses and have separate heating and cooling are considered to be low-rise residential buildings.

10. How does the Stretch code apply to historic buildings?

Historic buildings are exempt from both Stretch codes and the base energy code.

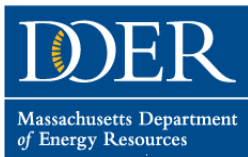

11. What is a HERS rating?

HERS stands for 'Home Energy Rating System,' and is a national standard that uses information on the design of the energy systems in a home to calculate, via computer modeling, the average energy needs of that home and give it a rating score. The HERS Index was developed by the non-profit Residential Energy Services Network (RESNET) for the mortgage industry and is utilized by the Federal Internal Revenue Service (IRS) and the LEED for Homes program. On the HERS 2006 index scale smaller numbers are better, with 0 representing a net zero energy home, and 100 represents a home built according to meet the national model energy code in 2006 (the IECC 2004 with 2005 amendments). A HERS rating of 52 means that the home uses about 48% less energy than the same size home built to the 2004/2005 IECC code requirements.

12. Do I have to get a HERS rating?

New low-rise residential buildings constructed under the Stretch code will have to get a HERS rating. The HERS performance-based approach provides a very good way to ensure that homes are not only well designed but also well built. As part of the HERS rating the home will be tested for air leakage, and under both the base and the Stretch code homes with heating and cooling ducts may also have those tested for leakage. The HERS rater, builder and building inspector can have confidence that the completed homes really are energy efficient.

Standards and Training:

13. What training and materials are available on the Stretch and Specialized codes

The Mass Save program provides training for code officials, builders, and design professionals. Visit their website at <https://www.masssave.com/en/learn/partners/energy-code-training-and-events> for scheduling.

DOER also provides technical experts to perform public outreach in municipalities that are considering a vote on the Stretch and/or the Specialized Stretch code. Those interested in this assistance should reach out to their regional Green Communities Coordinator

Process:

14. What is the process for adoption of the Stretch and Specialized energy codes?

Towns and cities in Massachusetts can choose to remain on the base energy code, adopt the Stretch energy code, or adopt the Specialized energy code as their mandatory energy code requirement. A municipality would remain on the base energy code unless and until it adopts the Stretch code or Specialized code through its appropriate public process.

15. How would a town or city adopt the Stretch and Specialized energy codes?

The Stretch code and Specialized code regulations may be adopted by any municipality in the commonwealth, by decision of its governing body. In a city having a Plan D or Plan E charter the governing body shall be the city manager and the city council, and in any other city the mayor and city council. In towns the governing body shall be Town Meeting.

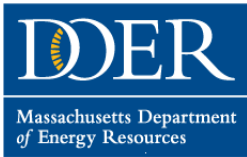

In order to be adopted, the regulations must be considered at an appropriate municipal public hearing, subject to the municipality's existing public notice provisions. Cities are advised to adopt the Stretch and Specialized energy codes by general ordinance and towns are advised to adopt the codes as a general bylaw. Current Stretch code communities wishing to adopt the Specialized code may choose to amend their existing ordinance or bylaw to refer to the new regulations. Municipalities should consult with their counsels on appropriate language.

Please note, once the Stretch and Specialized code is adopted by a municipality, all future editions, amendments and modifications are automatically adopted unless the municipality rescinds adoption of the code itself. A community must adopt the Stretch and Specialized code "as is," without applying any amendments or conditions.

Also note, according to the Attorney General's office:

Pursuant to G.L. c.40, S 32, neither general nor zoning by-laws take effect unless the town has first satisfied the posting/publishing requirements of that statute. Once this statutory duty is fulfilled, general by-laws and amendments take effect on the date that these posting and publishing requirements are satisfied unless a later effective date is prescribed in the by-law ...

DOER recommends that the warrant article, the motion and the by-law/ordinance explicitly specifies an effective date so that everyone (building officials, builders, homeowners, voters) is fully aware of when the Stretch and Specialized energy codes take effect. **It is further recommended that municipalities choose either July 1 or January 1 as the effective date.**

Enforcement/Requirements:

16. How would the Stretch code be implemented and enforced?

Once the Stretch or Specialized energy code is adopted by a town or city, it supplements the previous energy code language and becomes the binding energy code language for building projects in that municipality. Implementation and enforcement of the code is similar to existing code, where the developer is responsible for submitting documentation of compliance to the building inspector for review, and the building inspector conducts a site review.

17. What is the role of a building code official and a HERS rater for residential projects?

Residential low-rise buildings meeting the Stretch code through a HERS rating require independent certification by a HERS rater. Their work will produce a report detailing the energy systems in the building and will provide a HERS index score. In this way the local inspector retains their oversight role but the additional energy requirements are intended to not place a significant additional burden on their time.

18. How do I find a HERS rater?

HERS raters work with the residential builder/developer/design team and should be included in the team from the outset. Lists of HERS raters working in Massachusetts are available on the [Mass Save website](#), and from the [Northeast HERS Alliance](#).

19. What training and certification do HERS raters undergo?

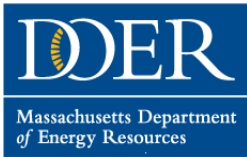

HERS raters are typically experienced building professionals, who in addition take a week or two week long intensive training course in residential energy efficiency. After completing the training, learning how to use HERS rating software, and passing a test, new raters must also complete at least 5 ratings with an experienced HERS rater before being able to independently award ratings. In addition to this initial training and certification, HERS raters must be affiliated with a certified HERS provider which is responsible for ongoing code education and quality assurance oversight of the HERS rater’s work. The HERS providers also carry liability insurance and allow builders to request a review from a second HERS rater in the rare case of disputes.

20. If my community has already adopted Stretch energy code, do we need to vote for it again?

No

Residential Building Questions:

R1. How do I meet the residential Stretch code for new 1 and 2 family homes and townhouses?

For new residential homes including multi-family homes of 3 stories or less, builders can choose to either meet Home Energy Rating Scores (HERS) certification or Passive House certification. Starting January 1, 2023, the maximum allowed HERS Index Score for residential low-rise construction ranges from 52 (for residences heated with fossil fuels) to 58 (for all-electric residences with on-site solar PV). HERS Index scores will be reduced to 42 and 45 starting July 1, 2024. Please review to Table 1 below:

TABLE 1: CHANGES TO MAXIMUM HERS INDEX

On-site Clean Energy Application	Maximum HERS Index score (before renewable energy credit)		
	New construction		Extensive Alterations, Additions and Change of use
	Updated Stretch Code July 1, 2024	Updated Stretch Code Jan. 1, 2023 <i>(Same as 10th edition base code)</i>	Updated Stretch Code (Jan. 1, 2023)
None (Fossil fuels)	42	52	52
Solar		55	55
All-Electric	45	55	55
Solar & All-Electric		58	58

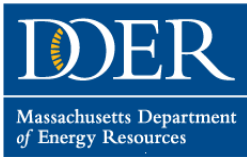

The 2023 Stretch Code maintains differential HERS ratings among new construction heating with fossil fuels, all-electric, and/or including onsite solar; after a phase-in period until July 1, 2024, which will require HERS 45 for all-electric homes and HERS 42 for homes with any use of fossil fuels.

The 2023 Stretch Code also updates HERS requirements for extensive alterations, additions and change of use for existing homes. Additional detail on alterations, additions and change of use can be found in the section below.

Builders wanting to achieve code compliance via Passive House certification will use the most recent Passive House Institute US (Phius) standards.

The updated Stretch code requires at least one space per home and a minimum of 20% of spaces in a new multi-family parking lot be provided with electric wiring to allow for **future EV charging**.

Existing buildings: Alterations, Additions and Changes of use:

The 2023 Stretch Code clarifies when alterations to existing homes trigger compliance with different requirements. The requirements are as follows:

- **Additions over 1,000 square feet (sf)** must follow the HERS Pathway and meet the HERS requirements for Additions in Table 1 above. Additions under 1,000 square feet will continue to follow Base Energy Code.
- **Additions that exceed 100% of the conditioned floor area of the existing dwelling unit** (ie. more than double the size of the house) must follow the HERS Pathway and meet the HERS requirements for Additions in Table 1 above.
- **Level 3 Alterations** (over 50% of the home is renovated and reconfigured) as defined in the International Existing Building Code (IEBC 2021) or change of use **exceeding 1,000 sf or exceeding 100% of the existing conditioned floor area**, must meet the HERS requirements in Table 1 above. Level 1 and Level 2 alterations will continue to follow the Base Energy Code.

R2. When is a HERS Rating required for an addition?

A HERS Rating is required where the total added conditioned floor area is greater than 1,000 square feet or the addition exceeds 100% of the existing dwelling unit conditioned floor area.

R3. If multiple additions are made to the same dwelling unit and each is under 1,000 square feet, but the total adds up to more than 1,000 square feet, is a HERS Rating required?

Yes, the floor area of multiple additions should be treated cumulatively. When two or more additions add up to greater than 1,000 square feet, a HERS Rating is required.

R4. Is the floor area trigger for when a HERS Rating is required for additions based on conditioned floor area?

Yes, only conditioned floor area is included when determining whether the addition requires a HERS Rating.

R5. Can a HERS Rating be performed on an addition?

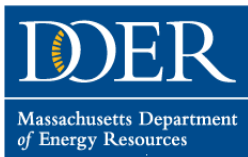

It depends. HERS Ratings may only be performed on dwelling units, so if the addition contains areas for living, sleeping, eating, cooking, and sanitation, a HERS Rating may be performed on the addition. If the addition is not a dwelling unit, the HERS Rating must be performed on the existing home plus the addition.

R6. Is a blower door test required for additions that trigger the requirement for a HERS Rating?

Yes. Blower door testing is a required element of a HERS Rating.

R7. Is a blower door test required for additions that do not trigger the requirement for a HERS Rating and are allowed to follow the prescriptive path?

In most cases, blower door testing is not required because passing the test would require performing work on the existing building. IECC Chapter 5 states that additions must comply as they relate to new construction “without requiring the unaltered portion of the existing building or building system to comply.” However, where feasible and practical, a code official could require testing of the addition alone.

R8. If an alteration meets the definition of a Level 3 alteration under the IEBC or an extensive alteration under IRC Appendix AJ, but does not exceed 1,000 square feet or 100% of the existing floor area, is a HERS Rating required? Likewise, if an alteration does not meet the definition of a Level 3 alteration, but exceeds 1,000 square feet or 100% of the existing floor area, is a HERS Rating required?

No. A HERS Rating is only required for alterations that meet the definition of a Level 3 alteration under the IEBC or an extensive alteration under IRC Appendix AJ **and** exceed 1,000 square feet or 100% of the existing floor area.

R9. Is the floor area trigger for when a HERS Rating is required for alterations based on conditioned floor area?

Yes, only conditioned floor area is included when determining whether the alteration requires a HERS Rating.

R10. Is a blower door test required for alterations that trigger the requirement for a HERS Rating?

Yes. Blower door testing is a required element of a HERS Rating.

R11. Is a blower door test required for alterations that do not trigger the requirement for a HERS Rating and therefore are allowed to follow the prescriptive path?

In most cases, blower door testing is not required because passing the test would require performing work on the existing building.

R12. Is EV readiness required for alterations?

No. EV readiness is only required for new construction.

R13. Is solar readiness required for alterations?

No. Solar readiness is not required for alterations. The solar-ready provisions apply only to new construction as Section R503 – Alterations makes no reference to Appendix RB Solar Ready Provisions.

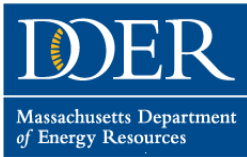

In addition, Appendix RB states that, “these provisions shall be applicable for new construction, except additions under 1,000 sq ft.”

R14. How much more does it cost to build to the Stretch code, and how does this compare to the energy savings?

It depends on how the new homes are heated. DOER compared costs for residential construction for four building types: 1) Large single homes (4,000 sq. ft.); 2) Small single family homes (2,100 sq. ft.); 3) 3-bedroom townhouses (2,100 sq. ft.); and 4) six-unit multifamily buildings (1,400 sq. ft per unit). The analysis compared construction costs between base code (HERS 52) and Stretch code (HERS 42) heated with natural gas and electric heat pumps. Including tax credits and Mass Save incentives, it is less expensive to build and operate Stretch code homes heated and cooled with heat pumps than those heated with natural gas built under the base code.

Costs and (savings) for residential construction under Stretch code (42 HERS) vs. base code (52 HERS)				
	Gas heat		Electric heat	
Size	Builder costs (savings)	Resident annual costs (savings)	Builder costs (savings)	Resident annual costs (savings)
4,000 sq. ft.	\$3,184	(\$302)	(\$20,062)	(\$548)
2,100 sq. ft.	\$7,907	\$496	(\$28,597)	(\$1,053)
Townhouse	\$62	(\$11)	(\$11,492)	(\$316)
Multi family	\$2,277	(\$14)	(\$15,690)	(\$683)

For more information on the residential cost studies, visit <https://www.mass.gov/doc/residential-stretch-code-costs-and-benefits-case-studies/download>

R15.. What are the Specialized code requirements for new residential construction?

The Residential low-rise Specialized Code offers 3 pathways to demonstrate energy code compliance with varying sets of additional requirements over and above the updated Stretch code:

- 1. Zero Energy pathway**
- 2. All-Electric pathway**
- 3. Mixed-Fuel pathway**

New homes up to 4,000 sf in size may follow any of the three pathways. **New homes over 4,000 sf in size shall follow either pathway 1 or pathway 2.** Table 2 below summarizes the low-rise residential Specialized Code requirements by home size and fuel use. All buildings are required to install wiring for electric vehicle (EV) charging in a minimum of 20% of new parking spaces, and one space per home in one- and two-family homes. Buildings with any combustion equipment designed for fossil fuel use are termed ‘mixed fuel’ buildings.

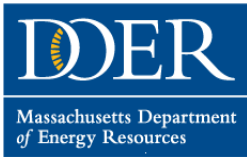

TABLE 2: Residential Specialized code requirements summary by building/dwelling unit size

Building Size	Fuel Type	Minimum Efficiency	Electrification	Min. EV wiring	Renewable Generation
Dwelling units up to 4,000 sf	All Electric	HERS 45 or Phius CORE or PHI	Full	1 parking space	Optional
Dwelling units up to 4,000 sf	Mixed-fuel	HERS 42 or Phius CORE or PHI	Pre-wiring	1 parking space	Solar PV (except shaded sites)
Dwelling units > 4,000 sf	All Electric	HERS 45 or Phius CORE or PHI	Full	1 parking space	Optional
Dwelling units > 4,000 sf	Mixed-fuel	HERS 0 or Phius ZERO	Pre-wiring	1 parking space	Solar PV or other renewables
Multi-family >12,000 sf	All Electric	Phius CORE or PHI	Full	20% of spaces	Optional
Multi-family >12,000 sf	Mixed-fuel	Phius CORE or PHI	Pre-wiring	20% of spaces	Optional

All Electric building performance standard

All electric buildings are defined in the updated Stretch Code and comply with the 2050 net-zero emissions performance standard by meeting the minimum efficiency standards of either HERS 45 or the Passive house pathway and using either air source or ground source heat pumps for primary space heating and heat pump or solar thermal water heating, as well as all electric appliances. All electric buildings are not required to install on-site solar panels but roofs must be solar-ready in accordance with the base and Stretch code requirements.

Mixed Fuel Pathway

New low-rise buildings **under 4,000 sf** using fossil fuels for any on-site use including space heating, water heating, cooking or drying must meet **minimum efficiency requirements of HER 42 or the Passive House pathway**. In order to demonstrate alignment with the 2050 net-zero emissions mandate, all homes or units using fossil fuels for space heating, water heating, cooking, or drying must install sufficient electrical service, space and wiring to allow for future conversion to all electric buildings.

These mixed-fuel homes and buildings utilizing the HERS pathway are also required to **install solar panels that provide no less than 4kw for single family** and not less than 0.75 W/ft² for multi-family, to mitigate these near-term emissions, with an exemption for shaded sites. Homes and buildings utilizing the Passive House pathway are exempt from additional solar install requirements, but must have solar-ready roofs consistent with both the stretch and base code provisions.

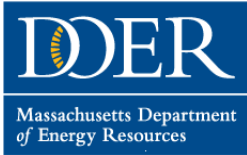

R16. Can I include a gas stove in a new home built under the Specialized Code?

Yes, provided the new home has **under 4,000 square feet** of conditioned space and is designed and built in accordance with the mixed-fuel pathway, which includes pre-wiring for future electrification of all heating, water heating, clothes dryers, and cooking equipment; meets HERS 42; and has onsite solar of not less than 4kW.

New dwelling units with **over 4,000 square feet** of conditioned space may install a gas stove, provided the building is designed using the **zero energy pathway**, meets HERS 0 or PHIUS 0 by including onsite renewables.

R17. How much solar PV would I have to install under the Specialized Code Mixed Fuel Pathway?

One- and two- family dwellings and townhouses are required to install a minimum of 4kW of onsite solar per dwelling unit, unless the potential solar zone area is less than 300 square feet.

R18. Can a home with a fossil fuel backup generator still qualify as “all-electric” to be eligible for the trade-off for clean energy systems (i.e., 3-point increase in maximum HERS Index)?

Yes. Fossil fuel powered backup generators are allowed in all-electric homes.

R19. My homesite is in the woods – do I have to cut down trees to meet the onsite solar requirements?

There are exceptions to the onsite solar requirements:

- Roof area oriented between 110 degrees and 270 degrees of true north of new one-and two-family homes and townhouses is under 600 square feet
- Roof area is in full or partial shade for more than 70 percent of daylight hours annually

R20. Are there additional requirements for extensive renovations or additions under the Specialized code?

No, extensive renovations and additions follow the requirements under the “regular” Stretch code.

Commercial Building Questions:

C1. What buildings are covered by the commercial Stretch code?

All non-residential buildings are covered by the commercial Stretch code starting July 1, 2023.

C2. What is required for new commercial buildings to comply with the Stretch code?

Depending on the building type, the updated Stretch code includes several code pathways for new construction.

1. **TEDI Pathway: Offices, residential, and schools** over 20,000-sf are required to use a new Thermal Energy Demand Intensity (TEDI) Pathway. The updated Stretch Code sets forth specific TEDI limits by

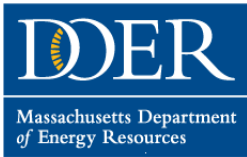

building type. This uses the same energy software tools as the current ASHRAE 90.1 Appendix G pathway but with significantly more focus on heating, cooling and the building envelope. Building uses adjacent to office and residential use, such as post offices, town hall, and other similar buildings are also covered under this pathway.

2. 10% better than ASHRAE Appendix G: High ventilation buildings such as labs and hospitals can continue to use a 10% better than ASHRAE appendix G pathway or opt to use the TEDI pathway. Multi-family buildings may follow the ASHRAE appendix G pathway until July 1, 2024. The updated Base Code and updated Stretch Code change the underlying ASHRAE standard 90.1 to the more recent 2019 edition.

3. Prescriptive pathway: Small commercial buildings (any building use except multi-family) under 20,000-sf will be able to continue to comply through an updated prescriptive pathway, or can opt to use the TEDI pathway. The prescriptive pathway is being updated in the Base Energy Code, and the updated Stretch Code includes additional amendments to improve efficiency beyond Base Energy Code for small buildings.

4. HERS and Passive House: Multi-family buildings larger than those covered by the residential low-rise code can choose between HERS and Passive House pathways that contain the same energy efficiency requirements as the updated Residential low-rise Stretch Code. The Passive House certification options remain available as an option for all building types.

	Updated Stretch Code July 1, 2023 through June 30, 2024	Updated Stretch Code Beginning July 1, 2024
Targeted Performance	Optional	Optional
HERS	Optional HERS 52/55	Optional HERS 42/45
Passive House	Optional	Optional
Relative Performance	Optional	Not allowed

Mixed-use buildings can use a combination of code pathways as appropriate for different portions of the building or choose a whole-building approach through the TEDI or Passive House pathways.

C3. How are commercial renovations and/or additions handled by the Stretch code?

The updated Stretch Code allows building additions which are less than 20,000-sf to continue to follow Base Energy Code. Additions greater than 20,000-sf will be required to meet applicable Stretch Code requirements for that building type and size. It will also require that any altered walls be brought up to prescriptive Stretch code, although historic buildings remain exempt from these provisions.

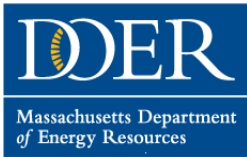

In addition, the updated Stretch Code will require buildings of any size which undergo **change of use or occupancy** to follow the new Stretch Code prescriptive pathway but allows for a 10% reduced envelope requirement for change of use compared to true new construction.

C4. What is TEDI?

Thermal Energy Demand Intensity (TEDI) measures the heating and cooling demand of a building in kBtu/sf-yr. **Heating TEDI** is the total annual energy **delivered** to the building for space conditioning and conditioning of ventilation air. **Cooling TEDI** is the total annual energy **removed** from the building for space conditioning and conditioning of ventilation air.

C5. Are there EV parking space requirements?

Yes. The updated Stretch Code raises the minimum number of spaces requiring EV wiring to 20% for business and residential space (from 10% required in the base code), with 10% for all other occupancies.

C6. What are the Specialized code requirements for commercial buildings?

The Specialized Code maintains the **same energy efficiency requirements as the Updated Stretch Code for all building types except multi-family**, including adoption of the ASHRAE 90.1-2019 pathway for high ventilation buildings, TEDI requirements for offices and schools, and a new prescriptive path for small buildings.

Multi-family buildings built to the Commercial Specialized Code must achieve precertification to **Passive House standards** (either from PHI or Phius). These requirements are phased-in for buildings up to 5 stories required to meet Passive House requirements if applying for permits after January 2023, and taller buildings 6 stories and above required to meet Passive House for permit applications beginning in January 2024.

There are three pathways for commercial Specialized code compliance:

1. All Electric Building Performance Standard

This is the simplest compliance pathway under the Specialized Code, requiring the energy efficiency requirements of the Stretch code, and requiring that all space heating, water heating, cooking equipment and drying equipment is powered by electricity and meets minimum efficiency standards.

2. Mixed-Fuel Building Performance Standard

This pathway establishes minimum requirements for new buildings designed with any space heating systems, water heating systems or appliances capable of using fossil fuels such as natural gas, heating oil or propane fuel. While allowing these fossil-fired systems, the Specialized Code requires mitigation of these emissions with the following requirements:

- a) Minimum efficiency requirements for space and water heating, including both fossil fuel and clean biomass boilers and furnaces systems.
- b) Solar development of the available on-site solar potential, specifically through one of 2

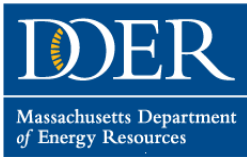

options:

- i.** *Not less than 1.5W/ft² for each sq foot of the 3 largest floors* (the threshold proposed in solar requirements in the forthcoming IECC2024), or
 - ii.** *not less than 75% of the Potential Solar Zone Area* – which includes parking areas and additional roof space.
- c) Pre-wiring and electrical service provision to the building to allow for future electrification of space and water heating and cooking and drying equipment.

Note: Off-site renewable generation or the purchase of Renewable Energy Credits (RECs), are not an option for compliance with the on-site renewable energy requirements in the Specialized Code.

3. Zero Energy Building Performance Standard

This is the most stringent of the 3 pathways in that it requires net zero energy on an annual basis from the 1st year of construction. The Specialized Code amends the IECC commercial appendix CC: Zero Energy Commercial Building Provisions by simplifying the allowable renewable options. As a result, zero energy may be demonstrated only with on-site generation (typically solar PV), and all buildings must meet minimum energy efficiency requirements prior to renewable offsets.

The option to show compliance using HERS 0 or Phius ZERO certification as used in the low-rise residential Specialized Code is also eligible under the Zero Energy pathway for multi-family residential buildings. solar PV), and all buildings must meet minimum energy efficiency requirements prior to renewable offsets.

The option to show compliance using HERS 0 or Phius ZERO certification as used in the low-rise residential Specialized Code is also eligible under the Zero Energy pathway for multi-family residential buildings.

Electric Vehicle Readiness Provisions

EV1. Under the Massachusetts Stretch Code, what does it mean for a parking space to be electric vehicle (EV) ready?

For a parking space to meet the EV Ready Spaces requirement, the space must be equipped with a dedicated electrical circuit. This means there needs to be adequate electric service capacity and wiring with a termination within 6 feet of the space. The dedicated branch circuit must be identified in the electrical panel or subpanel directory as "EV READY." The circuit must terminate in either a NEMA receptacle (standard outlet) or a Society of Automotive Engineers (SAE) Standard SAE J1772 electrical connector for servicing electric vehicles. The termination must also be marked as "EV READY".

EV2. What if the house does not have a garage, where is the circuit supposed to terminate?

The code requires the circuit to terminate within 6 feet of the parking space, regardless of whether there is a garage. The code does not contain termination requirements beyond the types of allowable termination. If a house does not have a garage, the electrician might consider terminating the circuit with

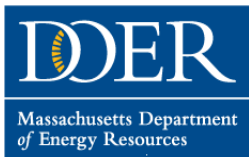

a weatherproof outdoor receptacle on the side of the home, embedded in parking area pavement, or on a post near the space.

EV3. Does EV readiness apply to buildings that have no onsite parking?

In the absence of onsite parking, EV readiness is not required. Exception 1 of R404.4 states that, “In no case shall the number of required EV Ready Spaces be greater than the number of parking spaces installed.” Further, exception 2 states that, “This requirement will be considered met if all spaces which are not EV Ready are separated from the premises by a public right-of-way.”

EV4. Many lake houses have parking spaces located across the street from the main structure. Is electric vehicle readiness required in these cases?

This requirement will be considered met if all spaces which are not EV Ready are separated from the premises by a public right of way.

Solar Readiness Provisions

S1. If the building design does not allow for the required solar-ready zone area due to obstacles such as vents, chimneys, and roof-mounted equipment, does the project still need to comply with the solar-ready provisions?

Yes. The stretch code adopts the IECC 2021 Appendix RB without amendments, and the appendix states that solar-ready zones shall be free from obstructions. In addition, a section on shading requires that the solar-ready zone is set back by a certain distance from any object on the building or site that will shade the zone. The code does not provide exceptions for rooftops with obstructions that interfere with the free area required for a solar-ready zone, so in these cases, a redesign is required. Designers should consider this requirement early in the design process.

S2. Is there a minimum solar electric system size for a home to meet the solar-ready provisions?

No. Appendix RB Solar-ready Provisions does not contain any requirements related to solar equipment, and as such, does not specify a minimum solar system capacity in kilowatts. The only size-related requirement is the area in square feet of the designated solar-ready zone. For homes with at least 600 square feet of roof area oriented between 110 and 270 degrees of true north, the solar ready zone must be at least 300 square feet. For townhomes with a total floor area of 2,000 square feet or less, the solar ready zone must be at least 150 square feet. The solar-ready zone may be split into multiple zones, but individual zone areas must be at least 80 square feet in area and at least 5 feet wide.

However, there are on-site renewable energy requirements for mixed-fuel new construction under the Specialized code.

S3. Do the Solar-ready Provisions require conduit or wiring to be installed from the solar-ready zone to the electrical panel?

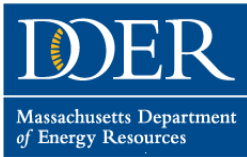

No. The Solar-ready Provisions require the construction documents to indicate pathways for routing conduit or plumbing from the solar-ready zone to the electrical panel or service hot water system, but no conduit, wiring, or plumbing are required to be installed. In addition, reserved space in the electrical panel labeled as “for future solar electric” is required, and for flat roofs, a capped roof penetration must be installed.

CITY OF NEWBURYPORT



IN CITY COUNCIL

ORDERED:

April 8, 2024

An Ordinance Establishing a Residential Seasonal Dock Permit and Fee

Be it ordained by the City Council of the City of Newburyport as follows:

THE Code of Ordinances, City of Newburyport, Massachusetts, is amended as follows:

The following is inserted in Article II, Division 4, Subdivision A, Section 4-72. – Definitions

Residential Seasonal Dock shall mean permitted temporary moorings of floats or rafts installed seasonally by residential property owners pursuant to Massachusetts General Laws Chapter 91, Section 10A.

The following is inserted in Article II, Division 4, Subdivision A, Section 4-73 (e). – Waterfront Fees

Residential Seasonal Docks shall be subject to an annual fee as defined and shown in Appendix B (Municipal Fees by Category). Said fee shall be dedicated 100% to the Harbormaster Enterprise Fund.

The following is inserted into Appendix B – Municipal Fees by Category, 2-B, Boats, docks and waterways (harbormaster department)

Residential Seasonal Docks	\$50/season
----------------------------	-------------

Councillor Sharif I. Zeid

Councillor James J. McCauley

In City Council April 8, 2024:

Motion to continue to a date certain, April 29, 2024, by Councillor Zeid, seconded by Councillor Zeid, seconded by Councillor McCauley. Roll call vote, 10 yes, 1 absent, motion passes.

In City Council April 29, 2024:

Motion to approve on 1st reading by Councillor Zeid, seconded by Councillor McCauley. Roll call vote, 11 yes, motion passes.

CITY OF NEWBURYPORT



IN CITY COUNCIL

ORDERED:

April 8, 2024

AN AMENDMENT TO AN ORDINANCE TO ADD A NEW HANDICAPPED PARKING SPACE PURUSANT TO SECTION 179 OF CHAPTER 13 (TRAFFIC AND MOTOR VEHICLES) OF THE MUNICIPAL CODE

Be it ordained by the City Council of the City of Newburyport as follows:

Chapter 13	Traffic and Motor Vehicles
Article 4	Specific Street Schedules
Division 6	Stopping, Standing and Parking
Section 13-179.2	Handicapped Parking Enforcement

Add Section 13-179.2 by inserting a new line, as follows, with deletions ~~double-stricken through~~, and additions double-underlined:

Any area designated as reserved for handicapped parking, whether public or private, where the public has right of access as invitees shall be enforced by any police or parking agency with jurisdiction within the municipal limits.

Chapter 13	Traffic and Motor Vehicles
Article 4	Specific Street Schedules
Division 6	Stopping, Standing and Parking
Section 13-179.3	Handicapped Violation - Penalty

Add Section 13-179.3 by inserting a new paragraph, as follows, with deletions ~~double-stricken through~~, and additions double-underlined:

Violation in any manner as to occupy or obstruct any parking space reserved for a vehicle, within the municipality, whether public or private, used by a disabled veteran or handicapped person whose vehicle bears the distinguishing license plate, or displays the special parking identification placard authorized by MGL c. 90, § 2, or bears the official identification of a handicapped person issued by any other state, or any Canadian province, will be punishable by a fine as established on the municipal fine and fee schedule in accordance with MGL c. 40, § 22A, and such vehicle shall be subject to towing at the owner's expense, as set forth under MGL c. 40, § 22D.

Councillor Jennie L. Donahue

In City Council April 8, 2024:

Motion to refer to Public Works & Safety by Councillor McCauley, seconded by Councillor Preston.
Roll call vote, 10 yes, 1 absent, motion passes.

In City Council April 29, 2024:

Motion to approve on 1st reading by Councillor McCauley, seconded by Councillor Shand. Roll call vote, 11
yes, motion passes.

CITY OF NEWBURYPORT



IN CITY COUNCIL

May 13, 2024

ORDERED:

A ZONING ORDINANCE AMENDMENT TO AUTHORIZE “COMMUNITY CENTER” USE ALONG THE SOUTHERN SIDE OF LOW STREET ACROSS FROM THE NOCK/MOLIN SCHOOL:

Be it ordained by the City Council of the City of Newburyport as follows:

THAT Section V-D of the Newburyport Zoning Ordinance, entitled “Table of use regulations” is hereby amended to read as follows with respect to the specific uses so noted, with deletions ~~double stricken through and in bold~~, and additions **double-underlined and in bold**:

USE	NUM	CON	HSR-A, HSR-B	R-1	R-2	R-3	B-1	B-2	B-3	I-1	I-1B	I-2	M	WMD	WMU
Community center	216	NP	NP	NP	P	NP	NP	NP	NP	NP	NP	NP	NP	NP	NP

NOTES:

- (i) **Reserved. Within the I-1 District any Community center facility shall be located within five hundred feet (500’) of an existing public school (Use 202).**

Councillor Heather L. Shand

Councillor Heath Granas

CITY OF NEWBURYPORT



IN CITY COUNCIL

ORDERED:

May 13, 2024

AN AMENDMENT TO AN ORDINANCE TO ADD NEW TRASH AND RECYCLING RULES TO SINGLE FAMILY HOMES ON PRIVATE ROADS PURUSANT TO CHAPTER 8 (HEALTH AND SANITATION) OF THE MUNICIPAL CODE

Be it ordained by the City Council of the City of Newburyport as follows:

Chapter 8	Health and Sanitation
Article 3	Solid Waste
Division 4	Trash Rules and Regulations
Section 8-101	Purpose
Section 8 - 102	Definitions
Section 8 – 103	Solid Waste/Recycling Program

Add Section 8-101, Section 8 – 101 and Section 8 – 103 by inserting a new line, as follows, with deletions ~~double-stricken through~~, and additions double-underlined:

Sec 8-101 Purpose

The purpose and intent of this ordinance is to define eligibility of households and regulate and reduce the amount of trash that an eligible household, institution or establishment can put out for curbside solid waste pick up; to encourage overall solid waste reduction; to reduce solid waste costs to the city and; to lessen the impact on the environment.

Sec 8-102 Definitions:

The following words, terms and phrases, when used in this chapter, shall have the meanings ascribed to them in this section, except where the context clearly indicates a different meaning:

Apartment building means a multi-family dwelling structure containing four or more units having access from an interior corridor system or common entrance.

Appliances means refrigerators, ranges, dishwashers, water heaters, freezers, air conditioners, washing machines, dryers, dehumidifiers, and trash compactors, which were originally intended for residential dwelling application.

Bulk item means furniture predominantly non-metallic, weighing over 50 pounds that does not fit into the official city trash cart.

Bulk item sticker means the sticker required for curbside bulky item pick up.

Condo Complex is a multi-family dwelling facility in which each unit is owned separately the residents living in it, but may also contain shared areas.

Household (HH) means the single residential unit within a single or multi-family dwelling.

Litter means any waste material which, if thrown or deposited in a manner prohibited by this article, tends to create a danger to public health, quality of life, safety and welfare.

Municipal collection program means the program that collects solid waste and recyclable materials including yard waste, eligible mixed use buildings, all municipal facilities or locations and city schools.

Organic Recycling means disposing of food waste by composting it wither in backyard composters, by curbside collection or public drop off with organics collector.

Park means and includes park, a reservation, playground, beach, recreation center or other public area in the city, owned or used by the city and devoted to active or passive recreation.

Private premises means and includes any yards, grounds, walks, driveways, porches, steps, docks, wharves or mailboxes belonging to or appurtenant to any dwelling, house, building or other structure.

Public place means and includes any and all streets, sidewalks, boulevards, alleys, or other public ways and any and all public parks, squares, spaces, grounds and buildings.

Recyclables shall mean glass containers, plastics #1 through #7, "junk mail," newspapers, clean corrugated cardboard, and tin/steel containers.

Recycling means any method, technique or system authorized to process or treat discarded materials so that its components, materials or substances may be beneficially used or reused.

Residential unit or dwelling means a dwelling within the city occupied by a person or group of persons and comprised of not more than four units.

Solid waste means household trash generated within the home and bulky items such as furniture, not including recyclable material, construction materials, or hazardous waste material or construction and demolition materials from remodeling.

Trash means material considered worthless, unnecessary or offensive that is usually thrown away. The term "trash" is generally defined as dry waste material, but in common usage it is a synonym for garbage, rubbish or refuse, but not to include recyclables or yard waste.

Yard waste means vegetation that includes: grass clippings, leaves, twigs, branches, brush (including Christmas trees), weeds and all organic material that can be composted, but not including, railroad ties or other yard related materials that has been treated with chemical preservatives.

Section 8-103 Solid Waste/Recycling Program

NOTE: As of June 2018- no new complex, business, or private road is eligible for trash and recycling service unless they meet the following criteria. Those complexes and private roads listed in Attachment A, who received these services prior to June 1, 2018 and do not meet that criteria, are grandfathered in.

Single Family Homes on Public Roads- are eligible for trash and recycling services.

Single Family Homes on private roads- are not eligible for trash and recycling services. Households contiguous to a public road are allowed to place trash barrels on public way with Board of Health approval and follow standard practice of the city approved trash program.

A HOA may request a variance to this policy by submitting an application, with documentation of the following: a letter of indemnity; proof of insurance; acknowledgement that this variance does not constitute "acceptance" by the city of these private roads as public nor does it entitle residents to additional city services like snow plowing; and must maintain a 50% enrollment rate in City sponsored Organic Recycling program, measured annually by the Sustainability Office. The application must be signed by all parties or HOA representing all parties on the private road and as determined by the city, the City Council (or is this BOH?) will approve with a majority vote.

Condo Complexes on private roads with 8 or more units are not eligible for city trash and recycling services.

Condos/town houses with public street frontage and separate entrances for each unit and less than 7 units are eligible for trash/recycling services as long as the sidewalks can accommodate the carts and as approved by the Board of Health. Each unit has to put out carts in front of their unit and follow standard practice for city carts.

Condo complexes and apartment buildings with one shared entrance (s) that are 8 units and above are not eligible for city trash/recycling service.

Food Establishments located in the downtown district (only) Each establishment will receive one (1) 64 gallon cart. Only the first 64-gallon cart is free. The rest must be in a purchased 15 or 30-gallon city sponsored trash bags. One cannot use a cart larger than 48 gallons.

Businesses outside of the downtown business district- No Service for trash or recycling.

Non-Profits Area non-profits and churches must abide by the same rules as residents. If there is a soup kitchen or food program these establishment must subscribe to compost collection for food waste at their own expense.

What is the total limit of trash? No more than 64 gallons (32-48-gallon carts) total are allowed to be put out each week per HH.

How much are the bags? The Newburyport crimson PAYT bags are \$2 for 15 gallon bags and \$4 for 30 gallon sized bags.

Where can one find the bags? Once the 64 gallon limit is reached and there is trash remaining the remaining trash may be disposed of in city sponsored bags which can be purchased at participating retailers.

Newburyport Housing Authority- Must abide by the same rules as residents of all households in the city.

Use of sidewalks –must be passable for pedestrians including people with disabilities and approved by the Board of Health.

Dumpster Service- Dumpster service will be offered and paid for by the city for municipal properties and properties that have existing service prior to moratorium set in June 2018. The size and number of pick-ups will be aligned to the number of units in the complex multiplied by 64 gal per HH. If additional dumpsters or pick-ups are needed then the complex pays the city's contractor directly.

Opt-out-People can opt out of city trash service if they'd like. No financial benefit for opting out.

Recycling –See Article III Solid Waste Division 2- Recycling ---for all rules and regulations for recycling. There is unlimited curbside pick-up of legal recycling material for all approved users. If a property does not qualify for municipal trash service, no recycling service will be permissible.

Illegal Dumping-There will be no placement of solid waste or recycling in a public place. Fines associated with this are detailed in Section 8 Article 3 of the City's ordinances.

Councillor James J. McCauley

COMMITTEE ITEMS

Committee Items – May 13, 2024

Budget & Finance

In Committee:

- TRAN00189_04_08_2024 Mayor's Office: General Fund Free Cash \$25,852.84 to
Fire Injured-on-Duty \$25,852.84 (COTW)
- ORDR00554_04_08_2024 Senior Work-Off Program Increase Max. Assistance Amount to \$2000 (COTW)
- TRAN00192_04_29_2024 Finance Dept.: LT Debt-Principal \$80,000 & LT Debt-Interest \$75,000
to Health Insurance Premiums \$155,000
- TRAN00190_04_29_2024 Mayor's Office: Interest on Short-Term Notes \$18,000 to Veterans Benefits \$18,000
- TRAN00191_04_29_2024 DPS:RRFA-Development Impact Fees \$30,000 to
Intersection Improvements Study \$30,000
- ORDR00560_04_29_2024 Gift Acceptance Hinkel Park Bench \$5000
- ORDR00561_04_29_2024 Gift Acceptance Pioneer League Batting Cage \$30,076.53
- ORDR00562_04_29_2024 Grant Acceptance Form FY23 FY24 Cultural District Grants \$30,000.00



CITY OF NEWBURYPORT FY 2024

RECEIVED
CITY CLERK'S OFFICE
NEWBURYPORT, MA

TRANSFER/APPROPRIATION REQUEST P 12:06

Department: Mayor's Office

Submitted by: Sean R. Reardon, Mayor

Date Submitted: 4/8/2024

Transfer From:

Account Name:	General Fund Free Cash	Balance:	\$ 2,318,144
Account Number:	01-35910	Category:	\$ -
Amount:	\$25,852.84	Trans I/O:	\$ (1,066,732)

Why Funds Are Available:

The Massachusetts Department of Revenue certified Free Cash for FY2024 at \$3,384,876. These funds are available for any legal expenditure with the approval of the Mayor and a vote of the City Council.

Transfer To:

Account Name:	Fire Injured-on-Duty	Balance:	\$ 9,459
Account Number:	01220001-51509	Category:	\$ 1,165,522
Amount:	\$25,852.84	Trans I/O:	\$ -

Why Funds Are Needed:

An appropriation is needed to cover payroll for the former fire chief through June 30, 2024. The City carries weekly indemnity coverage of \$1,000.00 resulting in a net budgetary need of \$1,988.68 per week. There are 13 weeks remaining in fiscal year 2025.

Sean R. Reardon, Mayor:

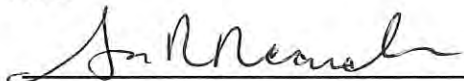

Date: 4/8/2024

Ethan R. Manning, Auditor:



Date: 4/8/2024

City Council Action:

CITY OF NEWBURYPORT



IN CITY COUNCIL

ORDERED:

April 8, 2024

That, effective for fiscal year 2025, the City of Newburyport increases the maximum abatement amount from \$1,500 to \$2,000 per fiscal year for senior citizens that participate in the property tax work-off program in accordance with [M.G.L. c. 59, § 5K](#).

Councillor Sharif I. Zeid

In City Council April 8, 2024:

Motion to collectively refer ORDR00551, ORDR00552, ORDR00553 to Budget & Finance, and ORDR00554, ORDR00555, ORDR00556, ORDR00557, ORDR00558 to Budget & Finance and COTW by Councillor Zeid, seconded by Councillor McCauley. Roll call vote, 10 yes, 1 absent, motion passes.



CITY OF NEWBURYPORT FINANCE DEPARTMENT

60 PLEASANT STREET
NEWBURYPORT, MA 01950
PHONE: 978-465-4404

WWW.CITYOFNEWBURYPORT.COM/FINANCE

SEAN R. REARDON
MAYOR

ETHAN R. MANNING
FINANCE DIRECTOR/CITY AUDITOR

To: President and Members of the Newburyport City Council

From: Ethan R. Manning, Finance Director/City Auditor

Date: April 4, 2024

Subject: Senior Tax Work-Off Program Increase to Maximum Assistance Amount

On October 4, 2023, Governor Healey signed “An Act to Improve the Commonwealth’s Competitiveness, Affordability, and Equity” into law ([St. 2023, c. 50](#)). Section 2 of the Act increased the maximum senior work-off abatement program amount from \$1,500 to \$2,000, pursuant to [G.L. c. 59, § 5K](#). Any increases may begin in fiscal year 2025. A majority vote of the City Council is required to effectuate this increase beginning July 1, 2024. Note that the maximum amount for the veterans' work-off program is still capped at \$1,500 per [G.L. c. 59, § 5N](#), so there is no increase available under that particular statute.

Below are the participation and earned benefits for the past three fiscal years. For the most recent fiscal year, the total property tax abatement provided by this program was \$57,655. We anticipate that the change to the maximum assistance amount could increase the amount abated per year by approximately \$20,000 to \$25,000, depending on participation. These abatements are charged to the “overlay” account, which is an amount that is carried in the annual revenue estimate for any property tax abatements and exemptions that are processed.

Year	# of Participants	Total Earned Benefit	Maximum Benefit (100 hours or \$1,500)	Maximum Benefit (133.33 hours or \$2,000)	Maximum Benefit Difference
FY21	22	\$28,327	\$33,000	\$44,000	\$11,000
FY22	47	\$71,413	\$70,500	\$94,000	\$23,500
FY23	42	\$57,655	\$63,000	\$84,000	\$21,000
				3-Yr. Average	\$18,500

Please see [IGR-2023-10](#) for more information on the senior work-off program. Details on how to participate in Newburyport’s program can be found on the Council on Aging website [here](#).

Thank you for your consideration.



CITY OF NEWBURYPORT FY 2024 TRANSFER/APPROPRIATION REQUEST

RECEIVED
CITY CLERK'S OFFICE
NEWBURYPORT, MA

2024 APR 25 P 2:45

Department: Finance Department

Submitted by: Ethan R. Manning, Director

Date Submitted: 4/29/2024

Transfer From:

Account Name:	<u>LT Debt - Principal</u>	Balance:	<u>\$ 165,000.00</u>
Account Number:	<u>0720009-59100</u>	Category:	<u>\$ 318,973.67</u>
Amount:	<u>\$80,000.00</u>	Trans I/O:	<u>\$ -</u>

Why Funds Are Available:

A surplus is anticipated at year-end due to the timing of debt issuance this fiscal year.

Transfer From:

Account Name:	<u>LT Debt - Interest</u>	Balance:	<u>\$ 146,973.67</u>
Account Number:	<u>0720009-59150</u>	Category:	<u>\$ 318,973.67</u>
Amount:	<u>\$75,000.00</u>	Trans I/O:	<u>\$ -</u>

Why Funds Are Available:

A surplus is anticipated at year-end due to the timing of debt issuance this fiscal year.

Transfer To:

Account Name:	<u>Health Insurance Premiums</u>	Balance:	<u>\$ 1,511,014.69</u>
Account Number:	<u>01914001-51700</u>	Category:	<u>\$ 1,679,887.62</u>
Amount:	<u>\$155,000.00</u>	Trans I/O:	<u>\$ -</u>

Why Funds Are Needed:

This account was underbudgeted for FY'24 due changes in plan enrollment and subscribers. Additional funds are needed to pay June 2024 health insurance premiums for city and school employees.

Sean R. Reardon, Mayor:



Date: 4/25/2024

Ethan R. Manning, Auditor:

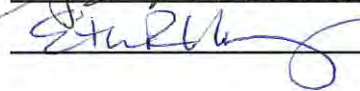

Date: 4/25/2024

City Council Action:



CITY OF NEWBURYPORT FY 2024

RECEIVED
CITY CLERK'S OFFICE
NEWBURYPORT, MA
2024 APR 29 10 35

TRANSFER/APPROPRIATION REQUEST

Department: Mayor's Office
Submitted by: Sean R. Reardon, Mayor **Date Submitted:** 4/29/2024

Transfer From:

Account Name:	<u>Interest on Short-Term Notes</u>	Balance:	<u>\$ 25,000.00</u>
Account Number:	<u>0720009-59250</u>	Category:	<u>\$ 1,074,604.93</u>
Amount:	<u>\$18,000.00</u>	Trans I/O:	<u>\$ -</u>

Why Funds Are Available:

There are currently no outstanding short-term notes; therefore, a surplus is anticipated in this account at year-end.

Transfer To:

Account Name:	<u>Veterans Benefits</u>	Balance:	<u>\$ 9,265.97</u>
Account Number:	<u>01543007-57700</u>	Category:	<u>\$ 11,028.37</u>
Amount:	<u>\$18,000.00</u>	Trans I/O:	<u>\$ -</u>

Why Funds Are Needed:

Three new recipients were added to the rolls after the FY2024 budget was finalized, with a total cost of approximately \$2,000 per month. The average total monthly payroll for veterans receiving Chapter 115 benefits this fiscal year has been \$11,500, with a projected total for the year of \$138,000. Since the approved budget was \$120,000, an \$18,000 transfer is requested.

Sean R. Reardon, Mayor:

Sean R. Reardon

Date: 4/23/2024

Ethan R. Manning, Auditor:

Ethan R. Manning

Date: 4/23/2024

City Council Action:



CITY OF NEWBURYPORT FY 2024

RECEIVED
CITY CLERK'S OFFICE
NEWBURYPORT, MA

TRANSFER/APPROPRIATION REQUEST

2024 APR 29 10 3: 35

Department: Department of Public Services
Submitted by: Wayne Amaral, Director **Date Submitted:** 4/29/2024

Transfer From:

Account Name:	<u>RRFA - Development Impact Fees</u>	Balance:	<u>\$ 30,000</u>
Account Number:	<u>2762-59630</u>	Category:	<u>\$ -</u>
Amount:	<u>\$30,000.00</u>	Trans I/O:	<u>\$ -</u>

Why Funds Are Available:

This is a receipts reserved for appropriation (RRFA) fund used to account for development impact fees received from developers in relation to development agreements. Funds are used to mitigate the impacts of developments on the surrounding neighborhood and the city overall. The \$30,000 in this account represents the first of two payments made to the city for a development on Colby Farm Lane. A second payment of \$30,000 will be made this year and will be reserved for appropriation in this same account.

Transfer To:

Account Name:	<u>Intersection Improvements Study</u>	Balance:	<u>\$ -</u>
Account Number:	<u>New Account</u>	Category:	<u>\$ -</u>
Amount:	<u>\$30,000.00</u>	Trans I/O:	<u>\$ -</u>

Why Funds Are Needed:

Traffic consulting work will be conducted to study and recommend improvements at the intersection of Low Street, North Atkinson Street, and Colby Farm Lane. The scope of work will also include support in applying for grant opportunities, such as MassDOT Complete Streets, Shared Streets & Spaces, and/or Safe Routes to School funding programs.

Sean R. Reardon, Mayor:  Date: 4/23/2024
 Ethan R. Manning, Auditor:  Date: 4/23/2024
 City Council Action:



CLIENT AUTHORIZATION

New Contract

TEC Project No.: _____

Amendment No.:

Date: April 19, 2024

Project Name: Low Street / North Atkinson Street / Colby Farm Lane Study – Newburyport, MA

Client: City of Newburyport Department of Public Services Attn: Wayne S. Amaral, Director 16A Perry Way Newburyport, MA 01950	Fee Proposal	
	Task 1 [Study & Concept Plan]	\$22,000.00
	Task 2 [Funding Support]	\$8,000.00
	Estimated Expenses	<u>Included above</u>
	TOTAL	\$30,000.00

Requested by: Client

Lump Sum Time & Expenses
 Cost + Fixed Fee Other

Estimated Date of Completion: Approx. 4 to 5 months following receipt of signed authorization

Scope of Services:

The City of Newburyport Department of Public Services (Client) has retained TEC, Inc. (TEC) to provide transportation planning and engineering services for a project located at the intersection of Low Street and North Atkinson Street / Colby Farm Lane in Newburyport, MA. This project will involve intersection analysis, a traffic safety review, conceptual design of intersection improvements, and grant funding application support. TEC will perform the services outlined in the task(s) below:

Task 1 – Intersection Study & Conceptual Improvements **LUMP SUM \$22,000.00**

Field Reconnaissance & Base Map Compilation

- Compile aerial images and mapping with approximate right of way and property lines from MassGIS, as available, to create a base plan suitable for a conceptual plan.
- Perform field reconnaissance to confirm existing intersection conditions, key features, lane widths, intersection geometrics, and roadway cross sectional dimensions.

Traffic Data Collection

- *Turning Movement Counts (TMCs)* – Perform 12-hour intersection TMCs (7:00 AM to 7:00 PM) at the following nine intersections:
 - Low Street at North Atkinson Street / Colby Farm Lane
- *Automatic Traffic Recorder (ATR) counts* – Collect roadway segment traffic data for a 48-hour mid-week period at one (1) location on Low Street in the project area and one (1) location along North Atkinson Street to document traffic volume, speed, and classification.

Warrant Analyses – TEC will perform left-turn lane, all-way stop control (AWSC), and/or traffic signal warrant analyses for the subject intersection.

Limited Traffic Capacity Analysis – Perform limited analysis to determine the existing roadway and intersection capacity conditions for a 10-year horizon to establish project need. This will consider the introduction of new traffic volumes from other known or permitted developments (City to provide copies of the Applicants' studies) and a reasonable regional growth rate based on discussions with MVPC.

Crash Data Compilation – Review the MassDOT crash database for the intersection for the most recent five-year period and assess the major crash trends at key intersections and along major roadway segments within the City limits. This does not include the preparation of detailed collision diagrams or formal Road Safety Audits (RSAs) at this time.

Conceptual Design Development – Provide recommended conceptual design options, if more than one is applicable, on a compiled aerial base map in AutoCAD Civil 3D that is consistent with the field reconnaissance, input from the City, traffic control alternatives, and cross-sectional needs that consider the latest MassDOT Complete Streets design standards where appropriate and feasible.

The intersection of Low Street / N. Atkinson Street / Colby Farm Lane has been identified as a key location that may benefit from State grant funding sources. This also includes approximately 1,100 feet of North Atkinson Street.

Cost Estimating: Prepare a planning-level construction cost estimate utilizing trending MassDOT average unit bid prices and their recently adopted SARPET construction pricing tool that is used for State funding applications.

Public Outreach Meetings - TEC will lead up to three (3) in-person public outreach meeting to review preliminary recommendations for the subject intersection and solicit public input. TEC will provide a summary of the comments received for the City's files.

Deliverables:

- Technical Memorandum – Initial Recommendations for the intersection of Low Street / N. Atkinson Street / Colby Farm Lane
- Color Concept Plan of intersection improvements; and
- Preliminary Construction Cost Estimate.

This assignment does not include the preparation of a survey, right-of-way research, or detailed intersection design documents, but will research the underlying roadway and intersection characteristics and the conceptual project needs to support certain MassDOT grant applications.

Task 2 – Grant Funding Application Support

ESTIMATED/HOURLY \$8,000.00

- Prepare application narratives for grant applications such as MassDOT Complete Streets, Shared Streets & Spaces, and/or Safe Routes to School funding sources. The City does not currently anticipate pursuing a formal Transportation Improvement Program (TIP) application at this time.
- Prepare a conceptual improvement graphic for approximately 1,100 feet of North Atkinson Street as a potential Safe Routes to School application.
- Attend coordination meetings (mostly virtual) with City or agency representatives to review the scope of the application(s).

The fee for this task is highly dependent on the number of applications that the City wishes to pursue. Therefore, TEC will perform this work on a time-and-expenses (hourly) basis.

Additional services not listed above may be performed at the request of the Client and will be considered an amendment to this agreement.

Services will begin upon signed authorization of this agreement. TEC will invoice the Client monthly on a percent complete (Task 1) or time and expenses (Task 2) basis for the services performed based on the task descriptions listed above. TEC direct expenses and the actual subconsultant and vendor/contractor services will be marked-up by 10% for Task 2.

This proposal is valid for a period of 45 days.

Project Manager: S. Gregorio

Approver: K. Dandrade

Please execute this Client Authorization for TEC, Inc. to proceed with the above scope of services at the stated estimated costs. No services will be provided until it is signed and returned to TEC.

Subject to attached terms & conditions

Subject to terms & conditions in our original agreement dated _____

TEC, Inc. Authorization

Client Authorization *(Please sign original & return)*

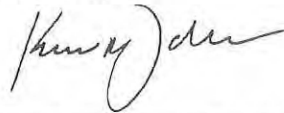

By



By

Print Name Kevin R. Dandrade, P.E., PTOE

Print Name Sean R. Reardon

Title Principal

Title Mayor

Date April 19, 2024

Date 4/23/2024.



CITY OF NEWBURYPORT GIFT ACCEPTANCE FORM

Ordered, that, the City of Newburyport accepts the following gift in accordance with M.G.L. Chapter 44, Section 53A:

Date of Gift:	3/22/2024	
City Department:	DPS Parks	
Staff Contact:	Michael Hennessey	
<i>Gift Overview</i>		
Gift Type:	Monetary	
Donor:	Philip K. Hinkel	
Purpose:	Donation of a park bench in memory of Janice M. Friske. See attached application.	
Gift Amount:	\$5,000.00	
<i>For Office Use Only</i>		
City Council Packet Date:	4/29/2024	
Emergency Measure?	<input type="checkbox"/> Yes	<input checked="" type="checkbox"/> No

Councillor Sharif I. Zeid

In City Council April 29, 2024:

Motion to collectively refer ORDR00560, ORDR00561, and ORDR00562 to Budget & Finance by Councillor Zeid, seconded by Councillor Harman. So voted.

Bench Application — 3/22/24 — — original —

Appendix A: Bench application

Name: Philip K. Hinkel

Address: 1870 COUNTY ROAD # 20745 FRIENDSHIP, WI 53934

Phone number: 815-988-6262

Email address: PKHINKEL @ HOTMAIL.COM

Preferred location for bench (up to 3):

MARKET SQUARE

ATTWOOD PARK

New or existing bench?: _____ new _____ existing DON'T CARE

Plaque selection:

- In Honor of/Name/Dedicated month & year: _____
- In Memory of/Name/Dedicated month & year: JANICE M. FRISKE 3-2024

I have read the Memorial Bench Policy and agree to abide by its terms.

Philip K. Hinkel
Signed

Please submit this application with a \$50 application fee made payable to the City of Newburyport. Applications and checks may be mailed to:

City of Newburyport
c/o Mike Hennessey, Parks Manager
60 Pleasant Street/ PO Box 550
Newburyport, MA 01950

For internal use only:



CITY OF NEWBURYPORT
GIFT ACCEPTANCE FORM

Ordered, that, the City of Newburyport accepts the following gift in accordance with M.G.L. Chapter 44, Section 53A:

Date of Gift:	3/21/2024	
City Department:	Mayor's Office	
Staff Contact:	Kim Turner, Manager of Special Projects	
<i>Gift Overview</i>		
Gift Type:	In-Kind	
Donor:	Newburyport Pioneer League https://www.nbtpioneerleague.org/	
Purpose:	The Pioneer League is looking to donate new batting cages at Lower Atkinson Common. The lowest quote obtained was \$20,576.53 plus \$9,500.00 for installation, for a total cost of \$30,076.53. It is a Mastodon Engineered Batting Cage System with two batting cages to be installed in the southwest (back-right) corner of Lower Atkinson Common next to Hawkes-Lapre Field. Staff confirmed with the Department of Labor Standards that prevailing wage law does not apply to this project. This project has approval from both the Parks Commission and Conservation Commission.	
Gift Amount:	\$30,076.53	
<i>For Office Use Only</i>		
City Council Packet Date:	4/29/2024	
Emergency Measure?	<input type="checkbox"/> Yes	<input checked="" type="checkbox"/> No

Councillor Sharif I. Zeid

In City Council April 29, 2024:

Motion to collectively refer ORDR00560, ORDR00561, and ORDR00562 to Budget & Finance by Councillor Zeid, seconded by Councillor Harman. So voted.



CITY OF NEWBURYPORT
GRANT ACCEPTANCE FORM

Ordered, that, the City of Newburyport accepts the following grant in accordance with M.G.L. Chapter 44, Section 53A:

Date of Award:	12/27/2022	
City Department:	Mayor's Office	
Staff Contact:	Kim Turner, Manager of Special Projects	
<i>Grant Overview</i>		
Grant Type:	State Grant	
Funding Agency:	Mass Cultural Council https://massculturalcouncil.org/	
Program Name:	FY23 & FY24 Cultural District Investment Grants https://massculturalcouncil.org/communities/cultural-districts/	
Project Name:	Newburyport Cultural District	
Project Description:	<p>FY2023 and FY2024 Cultural District Investment Grants provided funding, up to \$15,000 per year, for state-designated Cultural Districts. The funding from this grant is intended to encourage the development and success of these districts and to foster local cultural preservation in accordance with Massachusetts' Cultural Districts legislative statute. The FY23 grant of \$15,000 was awarded on December 27, 2022 (before the revised grant acceptance process took effect), and the FY24 grant of \$15,000 was awarded on January 9, 2024. Both grants will help to fund a new public art piece (Waterfront Ship Sculpture) at the newly renovated and expanded Market Landing Park. A "call for artists" has been issued with responses due by May 9, 2024. For more information, visit: www.cityofnewburyport.com/bids.</p>	
Award Amount:	\$30,000.00	
Payment Method:	Upfront Payment	
Length of Grant:	n/a	
Start Date:	n/a	
End Date:	n/a	
Award Acceptance Deadline:	Award acceptance deadline	<input checked="" type="checkbox"/> N/A
<i>Local Match/Required Resources</i>		
Local Match (City Funds):	No match is required.	
Local Match (In-Kind):	N/A	
Resources Required When Grant Program Ends:	Sculpture will be added to the City's property insurance schedule.	
<i>For Office Use Only</i>		
City Council Packet Date:	4/29/2024	
Emergency Measure?	<input type="checkbox"/> Yes	<input checked="" type="checkbox"/> No

Councillor Sharif I. Zeid

In City Council April 29, 2024:

Motion to collectively refer ORDR00560, ORDR00561, and ORDR00562 to Budget & Finance by Councillor Zeid, seconded by Councillor Harman. So voted.

Committee Items – May 13, 2024

Community Services

In Committee:

- APPT00483_04_08_2024 Kevin Hunt 14 Tenth St., Newbury Veterans Agent for Nbpt 5/1/2025
- COMM00525_01_08_2024 Letter from Joe Morgan re: Frog Pond Restoration Project
- COMM00541_02_26_2024 Kim Turner letter including supporting documents COTW)
- ORDR00474_07_10_2023 Plan Approval Bartlet Mall Improvement Project (COTW)



CITY OF NEWBURYPORT
OFFICE OF THE MAYOR
SEAN R. REARDON, MAYOR

60 PLEASANT STREET - P.O. BOX 550
NEWBURYPORT, MA 01950
978-465-4413 PHONE
MAYOR@CITYOFNEWBURYPORT.COM

To: President and Members
of the City Council

From: Sean R. Reardon, Mayor

Date: April 8, 2024

Subject: Re-Appointment

RECEIVED
CITY CLERK'S OFFICE
NEWBURYPORT, MA
2024 JAN 28 A 9:05

I hereby re-appoint, subject to your approval, the following named individual as Veterans Agent for Newburyport. This term will expire on May 1, 2025.

Kevin Hunt
14 Tenth Street
Newbury, MA 01951

KEVIN D. HUNT

14 Tenth Street
Newbury, MA 01951
978 465-1433 (H)
978 994-7747 (C)

email: veterans@cityofnewburyport.com

- 2007- Present** **Veteran Services Officer, Newburyport, MA**
- 1999 to 2007** **SYNERGENT, Data Processing sales – Service Bureau**
- 1994 – 1999** **EDS - Developed ATM networks with New England financial institutions. Consistently exceeded \$1M annual quota. Presentations to senior management, and knowledge of data communications and financial processing.**
- 1990 - 1994** **DIEBOLD CORPORATION, Canton, Ohio**
Developed and sold custom service offerings to New England financial institutions. Average sale \$75,000 over a six month cycle. Account responsibility for \$4.8M annual revenue. Leading sales producer.
- 1987 - 1990** **TECHNICAL SERVICES SUPPORT, INC., Ossining, NY**
Northeast Regional Sales Manager responsible for \$3M in existing revenue base, and new business development. Certified as *Novelle* Network Reseller. Regional offices closed in 1990 to consolidate cost.
- 1981 - 1987** **AUTOMATED DATA PROCESSING (ADP), Clifton, NJ**
Regional sales manager for ATM network development. Launched first Home Banking offering. Consistent over quota performance.
- 1969- 1978** **XEROX CORPORATION, Boston, MA**
Territory sales through to national account responsibility. Consistent over-quota performance.
- 1965 - 1969** **UNITED STATES NAVY**
Commissioned Officer - Vietnam and OCS Instructor
- EDUCATION:** **1963: University of Notre Dame, BA in Communications**
 1964: Fordham Law School
 1981: Doctorate in Chiropractic Medicine



Re: Frog Pond Restoration Project - Questions and Comments

1 message

Joseph Morgan <jmadisonmorgan@gmail.com>

Fri, Dec 22, 2023 at 10:42 AM

To: Kimberly Turner <KTurner@cityofnewburyport.com>

Cc: Andrew Levine <ALevine@cityofnewburyport.com>, James J. McCauley <JMcCauley@cityofnewburyport.com>, Connie Preston <CPreston@cityofnewburyport.com>, Jennie Donahue <JDonahue@cityofnewburyport.com>

Dear Ms. Turner,

Thank you for your response to my November 14 email regarding the proposed alterations to the Bartlet Mall and Frog Pond. Per your recommendations I have watched the recordings of the Conservation Commission and Planning Board meetings and reviewed the responses to questions from the Community Services Committee. The following are my findings relative to the questions that I asked you in my email:

1) Pond habitat: based on comments offered by Professor Vladimir Novotny, there was no survey of pond habitat performed by environmental biologists to determine the impact on aquatic wildlife in and around the pond. Without that information it seems that no one would be able to report on damage that might be inflicted on amphibian populations when the pond is de-watered and the sediment graded and capped. Why was such a survey not conducted prior to project design?

I found no answer to, and very little discussion of, this question from the Conservation Commission. The Notice of Intent was drafted without including habitat impact. Consequently, the City did not conduct a survey of animal and plant habitat so that it could be included with other “scientific evidence” used in the basis of design for alterations to the Frog Pond. Professor Novotny states in his September 5 presentation to the Community Services Committee that turtles inhabit the pond and are considered an endangered and protected species. I did hear concern expressed by the CC for the turtle population (hence an acknowledgement of animal habitat) once dewatering commences, but not enough to recommend an action plan such as a survey or rescue/relocation. Furthermore, The Secretary of the Interior Standards “Guidelines for Rehabilitating Cultural Landscapes” recommends documentation of plant and animal life during the survey of water feature existing conditions. <https://www.nps.gov/crps/tps/landscape-guidelines/preserve/water.htm>

2) Pumphouse: the original approved design for water recirculation was a pump housed in a concealed vault. Since that time the equipment scope has grown to the point where a 14-foot by 14-foot equipment room is needed to accommodate it. Moreover, that expanded footprint must now be housed in an architecturally designed pumphouse to make it compatible with the courthouse, as was discussed with the Planning Board. Based on a conversation with Professor Vladimir Novotny, I am concerned that the current equipment scope is overdesigned. The nanobubbler certainly seems excessive for natural pond restoration of this scale. Can examples be provided of other pond habitats that have been restored using a similar pumphouse design with similar equipment?

I found no answers to this question either from the meetings of the Conservation Commission, the Planning Board or the Community Services Committee. The latter asked the question about the design team’s experience but I noted no response giving other similar projects as examples. I have not found on the GEI and Aqueous Consultant websites examples of similar historical urban pond restorations (or any environmental pond restoration) demonstrating documented success with the proposed design and equipment. Nor did I once hear the GEI and Aqueous team members at the meetings refer to other projects to demonstrate proposed design principles or successful application of same. Based on my professional experience, I find it highly unusual to have hired

engineering consultants without having verified project-relevant experience. The engineering consultants appear to have considerable experience with environmental remediation caused by industrial pollution, larger civil projects and new park or recreational water features – but not with sensitive existing natural pond habitat within historic cultural landscapes.

3) Granite bench wall: I have been perplexed by the granite bench wall since I read the specification in the August bid documents. What had been originally reviewed and approved as a granite edge curb has become a raised basin wall. There appears to be no reason, functional, aesthetic, or historic as to why this change was made nor any consideration for the budget impact that it carries. How does this granite wall contribute to the project goals of pond water remediation?

There was a brief reference to the granite bench wall by Carol Wagan in the Conservation Commission’s meeting of May 16. Apparently, it was changed from the flush granite curb of earlier presentations (see rendering) to a raised granite block wall to keep out geese and ducks. This seems like an extreme solution to a problem for which other far less costly solutions are available – the granite wall has a \$600,000 price tag. It will deter other amphibian wildlife from returning to the pond since it forms a barrier between the beach and water. Finally, it is incompatible with the original Charles Eliot design for the pastoral landscape around the pond.



4) Dock: why is there a dock and how does it contribute to pond water remediation? The dock poses a drowning hazard for children; there is a playground just above it on the embankment.

Much discussion centered on the dock in the Conservation Commission meetings. Most seemed to be concerned with its weight, the details for rolling it in and out of the pond, and how it fits over the recirculation pump inlet pipe. One commissioner mentioned the public safety hazard but there was no serious response or follow up discussion concerning controlled dock access, rails, life vest storage, lighting, etc.

Also, the boating program is mentioned in Question 33 from the Community Services Committee. Your response refers to the 2016 pro forma report. In that document it assumes that revenues will be able to offset pond operating cost and maintenance. However, the “comparables” cited are much larger bodies of water in more dense communities (e.g. Manhattan’s Central Park) and in no way guarantee sufficient market analysis to suggest that there is sustainable interest in a boating program on a small historical green.

My general impression is that the dock idea has not been well thought out either from the public amenity side nor from the City finance/revenue side.

5) Historical landmark status: has the Massachusetts Historical Commission reviewed the project? The project intends to considerably alter this historic and cultural landscape that is cited both as a State and National landmark and recorded in their landmark registries. MHC is required to review any project that receives funding, licensing or permits by State or Federal agencies.

I reviewed your August 30 document summarizing project permits and do not see the Massachusetts Historical Commission cited. Whereas the project may have been exempted from permitting by MEPA and the US Army Corps of Engineers, it will be receiving State funds through the CPA which should trigger review by MHC. The MHC website states "...However, MEPA's thresholds do not apply to MHC's review of state funded or licensed projects. In general, all projects that require a permit, license or funding from any state agency must file a Project Notification Form (PNF) with the MHC, regardless of whether they trigger a MEPA threshold."

Based on my further review of the project, it is clear that there has been a change of project scope. In presenting the project to the Historical Commission in early 2022 there was little or no discussion of the intended recreational use. Indeed, the fact that the parks department was seeking CPA funds in the Historical Preservation category implied that the project goals were a sensitive and light-touch remediation of the pond while respecting the historical park design and existing plant and animal habitat. The Newburyport CPC evaluation criteria for this category states "Protect, preserve, enhance, restore and/or rehabilitate city-owned properties, features or resources of historical significance." The current solution does not conform to the requirements of historical preservation assuming that the pond was to remain a city park water feature for contemplation and passive enjoyment.

Since early 2022 there has been a shift away from the historic preservation goal toward recreational use of the pond. This would explain the heavy-handed approach to the engineering solution of capping the pond and adding complicated recirculation, a deep well and excessive aeration, thus destroying the existing pond ecology. The Parks and Conservation Commissions are used to working in tandem to provide much needed and valuable recreational amenities to the citizens of Newburyport. However, the current design, emphasizing recreation over preservation, threatens the historical town green in ways that are disrespectful of the peace, dignity and tradition of a much beloved community landmark.

Regards,
Joe Morgan
55 Hill Street

On Tue, Nov 28, 2023 at 11:40 AM Kimberly Turner <KTurner@cityofnewburyport.com> wrote:

Mr. Morgan,

I am in receipt of the email describing your concerns regarding the Bartlet Mall Restoration Project. I hope you can appreciate the time and effort that has gone into this project: looking at this centuries-old problem from every angle and assessing the proposed solution based on scientific evidence obtained by months of on-site testing and current technologies available to us, and ensuring that all regulatory agencies are satisfied that the solution balances ecological, historical and recreational needs against costs, long-range success and maintenance burden. No design decision has been taken lightly with regard to this project.

Indeed, every one of your proposed questions have been answered, in some cases multiple times, in public meetings and public documents. I encourage you to look on the City's website, under the Parks Commission page, where there is a tab dedicated to the [Bartlet Mall Restoration Project](#). There you should find answers to your questions. In particular, I point you to the responses to the 33 questions that the Community Services Committee posed to the design team. A recording of that meeting can also be found [on-line](#). I also encourage you to read the minutes or watch the meetings of the Conservation Commission's 5/2, 5/16, 6/6 and 7/18 meetings as well as the Planning Board's 7/19 and 8/16 meetings.

It is false that the originally approved granite edge was 6" height. From the earliest application to the Community Preservation Committee (as was sent to you via Historical Commission Chair Richards on 9/14), you can see that all renderings and application documents refer to a seat-height edge.

Sincerely,

Kim D Turner (*she/her*)

Manager of Special Projects

City of Newburyport

60 Pleasant Street

Newburyport, MA 01950

Office 978-465-4413

Cell 978-572-6767

KTurner@CityofNewburyport.com

Sign up for e-alerts and general City information on CityofNewburyport.com



--

Disclaimer

This communication from the City of Newburyport is intended only for the individual or entity to which it is addressed. If you are not the intended recipient, you are hereby notified that any dissemination, distribution or copying of this communication is strictly prohibited. If you received this e-mail in error, please notify the sender immediately and destroy this e-mail and all copies of it. Thank you.

The Commonwealth of Massachusetts considers most electronic communications to and from public employees to be public records and disclosable under the Massachusetts Public Records Law and its implementing regulations.

--

From: Joseph Morgan <jmadisonmorgan@gmail.com>

Sent: Tuesday, November 14, 2023 7:36 PM

To: Kimberly Turner <KTurner@CityofNewburyport.com>

Cc: Andrew Levine <ALevine@CityofNewburyport.com>; James J. McCauley <JMcCauley@CityofNewburyport.com>; Connie Preston <CPreston@CityofNewburyport.com>; Jennie Donahue <JDonahue@CityofNewburyport.com>

Subject: Frog Pond Restoration Project - Questions and Comments

Dear Ms. Turner,

After being introduced to the Frog Pond Restoration Project via my volunteer work with the Historical and Community Preservation Commissions, I most recently have followed the project by attending Planning Board and Community Services Committee meetings and reviewing the design documents issued for bidding. Whereas I am a supporter of the project's goals to clean the pond water, abate any serious source(s) of contamination and restore a healthy ecosystem, I am perplexed at certain aspects of the design, which I feel are extraneous to these goals. I have spoken to many others of my concerns but, as project manager, you are the best source for responding to my specific questions and comments since you know the entire history of the project. I would be most grateful for any further details you might provide regarding the following issues:

1) Pond habitat: based on comments offered by Professor Vladimir Novotny, there was no survey of pond habitat performed by environmental biologists to determine the impact on aquatic wildlife in and around the pond. Without that information it seems that no one would be able to report on damage that might be inflicted on amphibian populations when the pond is de-watered and the sediment remediated through dredging and capping. Why was such a survey not conducted prior to project design?

2) Pumphouse: the original approved design for water recirculation was a pump housed in a concealed vault. Since that time the equipment scope has grown to the point where a 14-foot by 14-foot equipment room is needed to accommodate it. Moreover, that expanded footprint must now be housed in an architecturally designed pumphouse to make it compatible with the courthouse, as was discussed with the Planning Board. Based on a conversation with Professor Vladimir Novotny, I am concerned that the current equipment scope is overdesigned. The nanobubbler certainly seems excessive for natural pond restoration of this scale. Can examples be provided of other pond habitats that have been restored using a similar pumphouse design with similar equipment?

3) Granite bench wall: I have been perplexed by the granite bench wall since I read the specification in the August bid documents. What had been originally reviewed and approved as a granite edge curb has become a raised basin wall. There appears to be no reason, functional, aesthetic, or historic as to why this change was made nor any consideration for the budget impact that it carries. How does this granite wall contribute to the project goals of pond water remediation?

4) Dock: why is there a dock and how does it contribute to pond water remediation? The dock poses a drowning hazard for children; there is a playground just above it on the embankment.

5) Historical landmark status: has the Massachusetts Historical Commission reviewed the project? The project intends to considerably alter this historic and cultural landscape that is cited both as a State and National landmark and recorded in their landmark registries. MHC is required to review any project that receives funding, licensing or permits by State or Federal agencies.

In general, from my perspective, there appears to have been substantial scope creep associated with the Frog Pond Restoration Project. Without survey data of the pond's habitat and clear project goals for accommodating an existing ecosystem, I am concerned that the pond has been labeled as a "toxic site" to be decontaminated and sterilized by the design team. I have heard remarks about the lack of relevant experience on the part of the engineering consultants, and it alarms me to think that the City may be implementing the wrong solution for "restoring" this cultural and historic landmark. I hope that there might still be an opportunity to circle back, review the project goals with all stakeholders, and have the entire design reviewed by experienced consultants in aquaculture restoration. A simpler, more cost effective, and eco-friendly solution may be identified that will save Newburyport, as well as Massachusetts, taxpayers a lot of money.

I thank you in advance for your knowledgeable assistance in this matter.

Respectfully,

Joe Morgan

55 Hill Street

From: **Kimberly Turner** <KTurner@cityofnewburyport.com>
Date: Thu, Feb 22, 2024 at 2:54 PM
Subject: supplemental information for 59 Low St
To: *City Council* <CityCouncil@cityofnewburyport.com>
CC: Andrew Levine <ALevine@cityofnewburyport.com>, Sean Reardon <SReardon@cityofnewburyport.com>

Dear Council,

I am writing to provide you with some additional information prior to your March 4 CS/COTW meeting regarding 59 Low St. I have compiled a document that contains a timeline, presentations and information that has been provided to date regarding this property. The aim is to provide the Council with a singular document with a comprehensive compilation of information that can be easily accessed. I have attempted to keep this information succinct and have provided links to the City website where greater detail, if desired, may be found. We look forward to our next presentation and conversation on March 4. As you know, we are currently at 100% Design Development documents for this project. This is Phase 2 of a typical 5-phase project and we are now looking for feedback prior to moving into Phase 3, Construction Documents. This is an appropriate time hear reactions from all stakeholders so that necessary changes can be made before moving forward.

The Order before you is to authorize the Administration to proceed with Phase 3 Construction Documents. \$200,000 was allocated for full architectural design. To date, 40% of the funds have been spent to bring us to 100% Design Development. The remaining 60% of the funds will cover Construction Documents, Bidding and Construction Administration, which are the last 3 phases of the 5 phase project.

Please do not hesitate to reach out should you be interested in additional information.

Thank you,

Kim D Turner (*she/her*)
Manager of Special Projects
City of Newburyport
[60 Pleasant Street](#)
[Newburyport, MA 01950](#)
[Office 978-465-4413](#)
Cell 978-572-6767
KTurner@CityofNewburyport.com



CITY OF NEWBURYPORT
OFFICE OF THE MAYOR
SEAN R. REARDON

60 PLEASANT STREET • P.O. BOX 550
NEWBURYPORT, MA 01950
(978) 465-4413 • (978) 465-4452 (FAX)
WWW.CITYOFNEWBURYPORT.COM

Ed Cameron, City Council President
City of Newburyport
60 Pleasant St.
Newburyport, MA 01950

February 20, 2024

Dear Councilor Cameron,

I would like to take this opportunity to provide the Council with documentation related to timeline, presentations and information that has been provided to date regarding the property at 59 Low Street. This project has a long history, and much information has been provided through numerous public meetings and working sessions. In order to make all this information easily accessible, it has been compiled into a single document. I have attempted to keep the information succinct and refer to the City website and/or previous meeting minutes and presentations where additional detail, if desired, can be found.

Timeline

- January 13, 2022: Budget and Finance meeting to review ORDR300_11_08_2021 to purchase 57 Low St. from free cash amended to assign temporary use. ([minutes linked](#))
- January 31, 2022: City Council unanimous approval to purchase 57 Low St. for \$220K as amended ([minutes linked](#))
- February 11, 2022: Deed recorded. ([deed](#) and [plan of land](#) linked)
- February 14, 2022: Property re-numbered from 57 to 59 to avoid confusion with the Armory. Post office, MAGIS and NextGen911 notified.
- February, 2022: Project manager identified (MSP Turner), internal meeting with NYS, Planning, DPS and Mayor's office, concept review of site plan with Engineer and MSP ongoing.
- March, 2022: Wetlands Scientist Hughes hired to flag wetlands, test pits dug by DPS, site meeting with Conservation Administrator.
- March 15, 2022: Conservation Commission meeting to update members about the project and discuss process of RDA. ([minutes linked](#))
- March 28, 2022: City Council presentation ([presentation linked](#)) of 'proof plan' showing that components of a new youth center, gym, parking and outdoor space could fit on the site, within the parameters of the current zoning and wetland restrictions. Discussion around need to re-flag wetlands since prior flagging was done in 2019, and is only viable for 3 years. Next steps identified: RDA with Con Com, hire an architect for Schematic Design, revise site plan as additional info becomes available with goal of 2 design options, request zoning change to

include community center use, prepare phased plan with associated costs, simultaneous review of Parks Facility location and Brown School.

March 30, 2022: General Government meeting to determine whether funds from the sale of the Kelley School could be used to pay for design for NYS at 59 Low St. remained in Committee ([minutes linked](#))

March-April, 2022: Requested proposals for Schematic Design and Cost Estimation. Per MGL, because scope below \$50K, three Architects were solicited for quotes: EGA (\$30K) ([proposal linked](#)), StudioMLA (\$32,850) and Douglas Architects (\$45K). Scope included review of historical info from the project site, including reports on environmental contaminants ([linked](#)) and review of program needs of the Department; conceptual design for the renovation of the existing structure at 59 Low St; addition of a modular gym and possible administrative space (max 1000 sf); cost estimation of the above; and a conceptual design alternative scenario that utilizes the gym/locker room/bathroom space at the Brown School both with and without associated administrative space, including associated costs.

April 6, 2022: Joint meeting between Planning Board and City Council to discuss zoning at the Business Park ([minutes linked](#)). Planning Board recommend to the City Council the adoption of the ordinance as amended (ODNC00105_02_2022): Amend the Newburyport Zoning Ordinance to address the permitted location of, and requirements for, various uses (especially within the I-1 & I-B Districts), and their associated parking requirements, titles, and descriptions, including but not limited to community center, boat sales/service/storage/rental, marine equipment sales, marine repair services, marine manufacturing, shipbuilding and repair, canvas and canvas products, seafood handling/distribution, marine retail, boat storage, marina and related. Planning & Development Committee voted to recommend to the City Council adoption of the ordinance as amended.

April 20, 2022: General Government meeting to determine whether funds from the sale of the Kelley School could be used to pay for design for NYS at 59 Low St. remained in Committee ([minutes linked](#))

April 28, 2022: Budget & Finance meeting to determine whether funds from the sale of the Kelley School could be used to pay for design for NYS at 59 Low St. Recommended amendment to source funds from free cash. ([minutes linked](#))

May 2, 2022: General Government meeting to determine whether funds from the sale of the Kelley School could be used to pay for design for NYS at 59 Low St. Recommended approval to the full council. ([minutes linked](#))

May 3, 2022: Conservation Commission opening of hearing to discuss RDA, site walk scheduled. ([minutes linked](#))

May 9, 2022: Site walk with the Conservation Commission at 59 Low St. City Council meeting: Motion to divide ODNC00105_02_14_2022 to table the amendment to the ordinance that would include Community Center as an approved use within the I-B District approved. Approval of TRAN00124_04_11_2022 RRFA Sale of Municipal Buildings \$30K to NYS Center Schematic Design. Approval of ORDR00319_02_14_2022 Kelley School Funds Order with amendment to reduce the amount of the funds from \$695,500 to \$595,500 and to add \$100,000 to a Brown School Stabilization Fund ([minutes linked](#))

May 17, 2022: Conservation Commission approval of the RDA for 59 Low St. This action set the wetland line for 3 years and allows a Notice of Intent (NOI) to follow based on the approved wetland line. ([minutes linked](#)) ([RDA linked](#))

June 28, 2022: Kickoff meeting with EGA to begin Schematic Design of 59 Low St. Architects and MSP met with Recycling and Energy Manager Ettenborough and Planning Director Port to discuss how City's Net Zero Ordinance impacts the design of 59 Low St. Discussed options for energy efficiency. Determined that geothermal is not an effective solution, but rather to focus on possibilities for solar and/or heat pumps within the system.

June-October, 2022: Schematic Design and Cost Estimation phase.

November 1, 2022: City Council presentation of the Schematic Design: 3 options with associated cost estimates, programming needs, and budget impacts were presented. Option A estimate is \$8,072,153, Option B estimate is \$5,746,851 and Option C estimate is \$2,999,764 or \$4,749,764 with a phased-in gym. ([presentation linked](#))

November 14, 2022: Planning & Development meeting to review COMM00444_11_01_2022 Net Zero Energy Goals for NYS ([minutes linked](#))

January 12, 2023: Budget & Finance meeting to discuss ORDR00388_11_01_2022 NYS Facility Bond Order and COMM00443_11_01_2022 59 Low St FAQ remained in committee. Director Egmont presented NYS needs and numbers, including an overview of services provided, an historical registration numbers, and program needs. ([presentation linked](#)) ([minutes linked](#))

January 30, 2023: City Council meeting motion to refer TRAN00148_01_30_2023 RRFA Sale of Municipal Buildings \$200,000 to NYS Center Design Services (with EGA Design Proposal) to Budget and Finance and COTW. The allocation of funds allowed the City to submit a formal RFQ for Design Services. ([minutes linked](#))

February 2, 2023: Budget & Finance meeting to discuss ORDR00388_11_01_2022 NYS Facility Bond Order and COMM00443_11_01_2022 59 Low St FAQ remained in committee. MSP Turner presented site suitability of 59 Low St, including what criteria were used to select the site for NYS, what other sites were considered, history of environmental cleanups and current A1 rating from DEP, wetland boundary, FEMA flood zone proximity, drainage patterns and approach to stormwater management, parking and traffic. Also discussed TRAN00148_01_30_2023 RRFA Sale of Municipal Buildings \$200,000 to NYS Center Design Services. Recommended to full Council with amendment: the design shall assume a total budget of \$2,000,000. A complete project shall constitute a property that can be accessed safely by users and includes safe crossing across Low St. The Council shall receive a copy of the plans and updated cost estimate as available but no less than at 50% and 75% design. ([minutes linked](#)) ([presentation linked](#))

February 13, 2023: City Council approved, with amendment stricken, TRAN00148_01_30_2023 RRFA Sale of Municipal Buildings \$200,000 to NYS Center Design Services (with EGA Design Proposal) which allowed the City to post an RFQ for design work to advance the Schematic Design through Design Development, Construction Documents, Bidding Assistance and Construction Administration. ([minutes linked](#))

February 16, 2023: Budget & Finance meeting to discuss ORDR00388_11_2022 NYS Facility Bond Order and COMM00443_11_01_2022 59 Low St FAQ. Recommend to receive and file

- while costs and funding needs are reviewed further during the design process. Finance Director Manning presented known and potential funding sources, bonding capacity, and potential impact of the project on budget and taxes. ([minutes linked](#)) ([presentation linked](#))
- February 27, 2023: City Council meeting motion to receive and file COMM443_11_01 59 Low St FAQ and ORDR00388_11_2022 NYS Facility Bond Order approved ([minutes linked](#))
- March 2, 2023: RFQ for Architectural services including Design Development, Cost Estimation, Construction Documentation, Bidding and Construction Administration posted and advertised in compliance with MGL. ([RFQ linked](#))
- March 7, 2023: Pre-bid walk-through of site for bidding Architects.
- March 22, 2023: Bids due for RFQ.
- March 24, 2023: Design Selection Board (DSB) comprised of MSP Turner, NYS Director Egmont, Associate Director of Youth Programs Gordon, Recreation and Enrichment Director Pauline, Assistant Engineer Federico, Zoning Enforcement Officer Blanchet, and COS Levine met to review the qualifications of the applicants and narrowed the number of candidates to 3: EGA, StudioMLA and SHED.
- March 31, 2023: Fee proposals were requested from the 3 finalists.
- April 12, 2023: DSB met to review the fee proposals and selected EGA (\$200,000) for having both the lowest bid and high qualifications ([proposal linked](#)).
- April 13, 2023: Notice of Award submitted.
- May 1, 2023: Contract signed.
- May-December, 2023: Design Development phase. Ongoing meetings with Architectural team. Individual meetings with Recycling and Energy Manager Ettenborough, Building Inspector Earls, Energy Advisory Committee members, IT Director Pope, DPS Director Amaral, MassSave, and Design Review Committee comprised of NYS Director Egmont, Zoning Enforcement Officer Blanchet, COS Levine, Associate Director of Youth Programs Gordon, Recreation and Enrichment Director Pauline, Facilities Manager Bartlett, NCOD Chair Farrell, parent and resident MacDonald, Assistant Engineer Gagnon, ADA Coordinator Morel, parent and contractor Lively to seek input and adjust the design based on feedback obtained.
- October 3, 2023: Community Services initial meeting to discuss ORDR00497 Administrative order for the Establishment of a Recreation and Youth Services Department ([minutes linked](#))
- October 11, 2023: Public hearing to discuss ORDR00497 Administrative order for the Establishment of a Recreation and Youth Services Department ([presentation linked](#))
- October 24, 2023: Community Services meeting to discuss ORDR00497 Administrative order for the Establishment of a Recreation and Youth Services Department. Recommended approval to the full Council. ([minutes linked](#))
- October 30, 2023: City Council meeting to approve ORDR00497 Administrative order for the Establishment of a Recreation and Youth Services Department. Unanimous approval. ([minutes linked](#))
- January 18, 2024: Community presentation to present the Design Development set, answer questions about the design and seek input to adjust the design based on feedback obtained. ([presentation linked](#)) ([3D walkthrough linked](#))

January 29, 2024: City Council meeting to discuss COMM00528_01_29_2024 Design & Cost Estimates Youth & Recreation Center. CC votes to receive and file with a request to resubmit as an order ([minutes linked](#))

February 12, 2024: City Council meeting to discuss ORDR00537_02_12_2024 Youth and Recreation Center Design Approval referred to Community Services and COTW ([minutes linked](#))

Additional Information

Site

In November 2021, a Site Selection Committee (SSC) was assembled to review various sites around the City where Youth Services might be located. The Committee identified 12 sites including the Brown School, Colby Farm Lane, Fulton Pit, Cushing Park, Bresnahan, etc. and identified a series of criteria by which the sites would be scored. These criteria included space indoors and out, parking, potential for growth, centralized location, cost, zoning concerns, environmental impact, etc. After a full review, the SSC identified four top choices: Cushing Park, the former Enpro site, Fulton Pit and 59 Low Street. The SSC ranked 59 Low Street among the highest because it would constitute a renovation project vs a new construction project, equating to a lower cost, and it was centrally located immediately across the street from the Nock-Molin Schools. However, the space was currently being used by the former Parks Department, who would need to find an alternative location for operations. ([report linked](#))

The site currently has an A1 rating from the Department of Environmental Protection (DEP) meaning the soil remediation that has occurred at the site has brought it back to 'background levels' that are consistent with sites immediately adjacent to 59 Low St, including the Nock-Molin Schools. The permitted activities that have occurred at the site include removal of an underground tank in 1986, soil remediation around the tank, and installation of a new tank. That second tank was then removed in 1995 and a second round of remediation occurred. In 1992, crushed stone containing PAH's was installed for use as parking at 59 Low Street. Between 1995-1998 a third round of remediation of the combined contaminants occurred. The DEP then designated the site with an A1 rating. ([report linked](#))

The wetlands at 59 Low Street were re-flagged in spring 2022 because the prior flags were 3 years old and were no longer valid for permitting. New flagging by Wetlands Scientist Hughes was completed based on soil samples and presence of vegetation using a scientific method. A Request for Determination of Applicability (RDA) was filed with the Conservation Commission, and a Negative RDA was issued, approving the wetland boundaries as delineated, after a site walk and public meeting. This Determination is valid for three years, during which time any project proposed on the site may utilize the approved delineation. ([RDA linked](#))

In October 2021, as part of a Phase II ESA conducted by Credere Associates, LLC, eight soil borings were drilled during the environmental assessment on the easterly end of the site between the building and Low St. These borings were drilled to refusal on bedrock which ranged from 10-14.5' below ground surface. One boring was terminated at 15' below surface and consisted of no refusal. Samples were consistently wet around 5' below surface and consisted of sand with bands of clay and some silt and fine gravel. ([presentation linked](#)) To supplement these findings, the City dug two test pits in March of 2022: one approximately 10' off the west side of the existing building and the other to the south of the property just beyond the paved area. Soils were consistent with the prior report: a clay layer was uncovered approximately 2' below surface. Therefore, due to the presence of clay soil and groundwater elevation, a surface treatment detention pond was recommended for stormwater management to treat

the water before discharge into wetlands. Runoff was modeled using HydroCAD software to determine an appropriate size for said detention pond which is shown on the Schematic and Design Development site plans.

The FEMA 100-year flood zone plus 6' SLR does not come near to this site. The nearest floodplain is at a stream along Parker street at flood elevation 10, 88NAVD. The elevation of the 59 Low Street lot is typically above 20, meaning there is no floodplain risk. There is currently no existing stormwater management on this site. Stormwater management is included with the current site design, which will mitigate any localized stormwater based flooding which generally would occur behind the existing fence away from the building.

Traffic and Pedestrian Safety

The current site plan shows 23 parking spaces, which satisfies the current zoning of 1 space per 500 sf of GFA. Two of the 23 spaces are designated as handicapped accessible, in close proximity and accessible to the front door, with a designated loading area.

Since most attendees of the Recreation Center are children, a decision was made during the Schematic Design phase to accommodate two curb cuts at the property, with a one-way vehicular circulation pattern that would allow parents to drop off children and exit back onto Low St. Morning programs are currently limited to 12 families, and would be easily accommodated by the 23 parking spaces. After school programs primarily consist of children walking or biking to the facility (no parking needed for these attendees), and parent pickup, which would be staggered, would be accommodated by the driveway loop. After hours events, if drawing more than 23 vehicles, could utilize shared parking with the Nock-Molin School parking lot across the street.

The current cost estimate for sidewalk and safe pedestrian crossing at 59 Low St is \$243,000. This includes design and construction of an accessible sidewalk to access the facility from the Nock-Molin School across the street, as well as some drainage work. The sidewalk would run across the frontage of 59 Low St to the front door of the facility. The estimate also includes installation of an overhead mast arm mounted Rapid Flashing Beacon (RFB) at a designated crosswalk across Low Street between the facility and the Nock-Molin School.

Energy Efficiency and Net Zero

In late 2021, the City of Newburyport adopted ODNC 00111_05_09_2022 to define its Net Zero Energy Goals as they relate to Municipal Facility Design. While the Ordinance does not explicitly require new or renovated facilities to meet an absolute net zero threshold on usage, it does require that any gap in on-site generation be pulled from the electric grid. It also requires generation of a report quantifying the gap between on-site generation and usage. The report must be submitted and reviewed by the Mayor and Council in relation to funding for, and construction of, the project. The ordinance also requires that the City's municipal facilities consume the minimum amount of energy and results in minimal emissions of greenhouse gasses associated with such energy usage.

As such, the following elements are included in the design of this project in order to reduce energy usage and reduce greenhouse gas emissions:

- Triple pane windows;
- Fixed windows to reduce air infiltration;
- Minimal exterior openings to reduce air infiltration;

- Spray foam insulation throughout to minimize air infiltration through walls and roof;
- Additional exterior insulation to exterior walls and roof at new addition and gym;
- Under slab insulation at new addition and gym;
- No natural gas;
- All electric mechanical systems including high efficiency electric heat pumps;
- Heat recovery ventilation system to recapture heat from ventilation air;
- Occupancy sensors on lighting;
- Heat pump domestic hot water heater;
- Insulated domestic water piping;
- Variable frequency drives on motors to reduce energy consumption;
- Building prepped for future installation of solar panels; and
- All LED lighting.

The City is currently working with MassSave, through its Commercial New Construction & Major Renovation Program, to take advantage of both technical assistance and financial incentives through its Path 3: High Performance Buildings category. The City has received technical assistance review of our Design Development documents in order to help identify energy and electrification opportunities, create an energy savings report and customize incentives. Their suggestions have been incorporated into the design. Custom incentives may include partial reimbursements on electricity usage as well as funding for heat pumps. Incentives will be pre-approved during the 100% Construction Documentation phase, when the City will be able to apply for commitment.

Program Needs

Newburyport Recreation and Youth Services currently provides recreation and enrichment programs for children and families; hosts community events; provides Youth Center memberships, programs, trips and clubs for middle school and high school students; and provides supports for positive youth development, social work and substance abuse prevention through community and regional partnerships. In order to provide these services, the Department requires space for children and families to congregate as well as for their administrative staff to operate. Since the closing of the Brown School in 2021, the Department has utilized multiple satellite spaces to continue to function, which has created adverse impacts on the services the Department has been able to provide.

During 2022, the Department accommodated 5,137 activity registrations, 207 membership registrations and ran 531 activities. These registrations were overwhelmingly from residents of Newburyport, which make up just under 90% of users. There are currently 145 active memberships to the Youth Center. In 2022, the Department generated \$655,750 in revenue from registration and activity fees.

During a typical day, the Department has a need for classroom space, gym space, and administrative office space. The needs are spread across morning hours (play groups, early literacy, art and music classes, open gym, movement, etc.) for toddlers; afternoon hours (clubs, Youth Council, enrichment classes, pickup sports, club sports, private rentals, etc.) for middle and high schoolers; and evening hours (certificate courses, community meetings, NBBA/NGBA rentals, men's basketball, parent speaker series, community events, etc.) for students and adults, during all times of the year.

Design

This project includes renovation of the existing former Emergency Management building at 59 Low Street, plus the addition of a 1-story lobby/toilet/reception area and modular gym. The total square

footage of the new facility is 11,166 sf broken into 5,920 sf existing building, 1,181 sf lobby addition, and 4,065 sf modular gym. In addition, the project will utilize existing attic space to create 1,440 sf of storage and mechanicals which will be accessed from a stairway near the administrative offices.

The structure will be fully sprinkled and contain a fire alarm system. There are 5 women’s toilets (1 ADA) and 4 men’s toilets (1 ADA and 1 urinal), plus one gender-neutral, family restroom with a changing station. There are sinks located in the restrooms, Early Ed space as well as the Art Room, which has separate sinks for food prep and art activities. The Art Room also contains a range and countertop space. There is a water bottle refill station in the Lobby. There are 5 offices to accommodate all staff, with flexibility to utilize the Quiet Study as a cross-over conference room. Storage will be provided at the Gym, Early Ed, Art Room and Teen Hangout, with additional storage available in the attic. In addition, there will be cubbies for student use in the corridor to the Teen Hangout and within the Early Ed space. The Teen Hangout will also contain a pull-down screen for presentations and movies, as well as a game area and ample, movable seating. All areas are fully accessible with appropriate fixtures and highly flexible to accommodate a variety of programs and uses. The occupancy of the facility is 532, including 252 within the gym.

The program spaces within the building consist of the following:

- Enclosed Entry Vestibule:..... 129 sf
- Lobby including snack area:..... 551 sf
- Reception/Concession desk:..... 72 sf
- Toilets including family/staff toilet:..... 599 sf
- Early Ed space:..... 688 sf
- Corridors and Stair to upper storage/mechanicals:..... 598 sf
- Offices:..... 487 sf
- Multi-purpose Room:..... 272 sf
- Art Room:..... 835 sf
- Quiet Study:..... 399 sf
- Teen Hangout:..... 1,702 sf
- Gym:..... 4,065 sf

The outdoor area will include a separate, fully fenced-in play space for the Early Ed users along the north of the property, with access from the Early Ed space. It will also include a half-sport court and patio, as well as an open lawn area.

Budget

Several design decisions were made with an eye to reducing costs for this project. These include the following:

- Maximizing the use of the existing building, including adding a partial second level for storage and mechanical systems;
- Minimizing modifications to the existing exterior façade and re-using as many existing window locations and door openings as possible;
- Minimizing trenching of the existing slab: this is why public toilets were installed in a new addition;
- Re-using existing CMU walls in the building to minimize demolition costs;
- Minimizing the footprint of new additions;
- Minimizing corridors to maximize available space;

- Designing spaces so they are flexible and can be used for multiple purposes;
- Using simple, geometric forms and gypsum wall board with paint;
- Installing electrical service and domestic hot water at the front of the building to minimize service piping and wiring; and
- Using modular construction for the gym to minimize on-site construction costs: this is a highly efficient system for spaces with large spans such as a gym.

Per their contract, EGA subcontracted PM&C cost estimators to provide pricing for their Design Development Set. The estimates came in at \$6.9M, which the Architects felt was conservatively high. EGA then asked for a second opinion from a contractor who had experience with these types of projects, in order to provide their client (the City) with additional information. The second estimate came in at \$6.2M. This was not issued as an IFB, meaning the project will still require a formal IFB once Construction Documents are completed. Design Development sets are a mid-set of a design, meaning there are still refinements that are made before the Construction Document phase begins.

The project's primary funding would come from a General Fund borrowing authorized by M.G.L. c. 44, §7(1), repaid annually with interest over a term not exceeding 30 years. Estimated annual debt service on a \$6.0 million bond would be \$345,000 per year based on a AAA rating and 4.0% interest rate. Debt service would be funded within the existing levy limit and incorporated into the annual budget for the City following the issuance of bonds and/or notes. Additionally, there is a remaining balance of \$393,500 from the 2016 sale of the former Kelley School, available for appropriation to the project, along with \$25,000 earmarked in the FY2024 state budget for furnishings and equipment at the proposed facility. Other potential funding sources include grants, private donations, facility fees, funds from the American Rescue Plan, adoption of new or increased local option taxes, and funds received from opioid settlement agreements.

Carrying Costs and Maintenance:

Based on the usage per square foot at the Senior/Community Center (\$1.68/sf per year for 15.5K sf), the proposed Rec Facility (+/-11K sf) would cost approximately \$18K/year for heating, cooling and electricity. The building size and parking area of this new project are roughly equivalent to the portions of the Brown School that were utilized for NYS. As such, it is reasonable to assume the current manpower at DPS could handle this new project under their current staffing capacities.

Moving Parks Division to Perry Way

The Parks Division will move to Perry Way, where an office space for the Parks Manager, a staff breakroom and locker room, and a heated workshop already exists. A new exterior work storage area will need to be constructed to protect existing parks equipment that is currently housed at 59 Low Street. The costs to create the additional storage space will be as follows:

1. 2 40' storage containers with easy access doors:	\$25,000
2. 1-40' standard storage container	\$ 9,000
3. Storage container roof	\$50,000
4. Electrical hookups	\$ 8,500
5. Site work	\$ 4,500
6. 10% contingency	\$ 9,700
TOTAL	\$ 106,700

We look forward to continuing this conversation with the Council and the Community at the next Community Services meeting on March 4. In the meantime, please do not hesitate to contact me with any additional questions or concerns.

Sincerely,

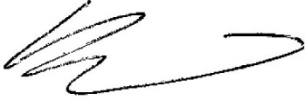
A handwritten signature in black ink, appearing to be 'Kim Turner', written in a cursive style.

Kim Turner, Manager of Special Projects

DESIGN DEVELOPMENT COST ESTIMATES

12/5/2023

PM&C

SOUTH COAST

Item	Amount	Amount
SITE WORK	\$ 774,118.00	\$ 666,488.00
Site prep and demolition	\$ 221,659.00	\$ 164,667.00
Site improvements	\$ 322,984.00	\$ 501,821.00
Civil mechanical utilities	\$ 97,075.00	\$ -
Electrical utilities	\$ 132,400.00	\$ -
REMOVE HAZARDOUS MATERIALS (Credere Assoc 2021 costs escalated)	\$ 127,920.00	\$ 144,517.00
BUILDING CONSTRUCTION: RENOVATION, NEW CONSTRUCTION, GYM	\$ 4,353,655.00	\$ 4,123,809.00
Foundations	\$ 257,522.00	\$ 276,109.00
Superstructure	\$ 75,999.00	\$ 359,197.00
Exterior closure	\$ 392,015.00	\$ 514,284.00
Roofing	\$ 118,684.00	\$ 115,317.00
Interior construction	\$ 612,266.00	\$ 932,604.00
Interior finishes	\$ 405,016.00	\$ 483,239.00
Plumbing	\$ 249,013.00	\$ 205,717.00
HVAC	\$ 762,485.00	\$ 593,717.00
Fire protection	\$ 109,301.00	\$ 101,217.00
Electrical	\$ 553,169.00	\$ 371,324.00
Equipment	\$ 59,000.00	\$ 19,073.00
Furnishings	\$ 171,935.00	\$ 57,517.00
Special construction	\$ 587,250.00	\$ 94,494.00
Hazmat removals	\$ -	\$ -
PROJECT COSTS	\$ 1,714,745.00	\$ 1,294,412.00
Design & pricing contingency	\$ 136,648.00	\$ 370,561.00
Escalation (July 2024 start)	\$ 131,392.00	\$ -
General conditions	\$ 788,354.00	\$ 425,628.00
Bonds	\$ 63,121.00	NIC
Insurance	\$ 78,901.00	\$ 110,224.00
Permit	NIC	\$ 50,713.00
Overhead & fee	\$ 516,329.00	\$ 337,286.00
OPM	\$ 348,521.90	\$ 311,461.30
SUBTOTAL	\$ 7,318,959.90	\$ 6,540,687.30
PEDESTRIAN SAFETY & INFRASTRUCTURE	\$ 243,000.00	\$ 243,000.00
Design & survey	\$ 48,000.00	\$ 48,000.00
Sidewalk construction	\$ 85,000.00	\$ 85,000.00
Drainage	\$ 25,000.00	\$ 25,000.00
RFB installation overhead arm	\$ 85,000.00	\$ 85,000.00
MOVE PARKS DIVISION TO PERRY WAY	\$ 106,700.00	\$ 106,700.00
TOTAL	\$ 7,668,659.90	\$ 6,890,387.30

DESIGN DEVELOPMENT COST ESTIMATES
12/5/2023

PM&C

Item	Amount
RENOVATION	\$ 2,255,568.00
Foundations	\$ 4,000.00
Superstructure	\$ 39,600.00
Exterior closure	\$ 241,125.00
Roofing	\$ 43,637.00
Interior construction	\$ 441,530.00
Staircases	\$ 21,500.00
Interior finishes	\$ 208,919.00
Plumbing	\$ 112,304.00
HVAC	\$ 423,876.00
Fire protection	\$ 70,400.00
Electrical	\$ 329,296.00
Equipment	\$ 15,000.00
Furnishings	\$ 168,117.00
Special construction	\$ -
Selective building demolition	\$ 136,264.00
SITE WORK	\$ 637,854.00
Site prep and demolition	\$ 85,395.00
Site improvements	\$ 322,984.00
Civil mechanical utilities	\$ 97,075.00
Electrical utilities	\$ 132,400.00
REMOVE HAZARDOUS MATERIALS (Credeire Assoc 2021 costs escalated)	\$ 127,920.00
NEW OFFICE AND MECHANICAL ADDITIONS	\$ 864,699.00
Foundations	\$ 66,261.00
Superstructure	\$ 36,399.00
Exterior closure	\$ 150,890.00
Roofing	\$ 75,047.00
Interior construction	\$ 126,000.00
Interior finishes	\$ 86,487.00
Plumbing	\$ 94,184.00
HVAC	\$ 105,334.00
Fire protection	\$ 13,588.00
Electrical	\$ 99,691.00
Equipment	\$ 7,000.00
Furnishings	\$ 3,818.00
Special construction	\$ -
Hazmat removals	\$ -
GYM	\$ 1,369,652.00
Foundations	\$ 187,261.00
Interior construction	\$ 23,236.00
Interior finishes	\$ 109,610.00
Plumbing	\$ 42,525.00
HVAC	\$ 233,275.00
Fire protection	\$ 25,313.00
Electrical	\$ 124,182.00
Equipment	\$ 37,000.00
Furnishings	\$ -
Special construction	\$ 587,250.00
Hazmat removals	\$ -
PROJECT COSTS	\$ 1,714,745.00
Design & pricing contingency	\$ 136,648.00
Escalation (July 2024 start)	\$ 131,392.00
General conditions	\$ 788,354.00
Bonds	\$ 63,121.00
Insurance	\$ 78,901.00
Permit	NIC
Overhead & fee	\$ 516,329.00
TOTAL	\$ 6,970,438.00

CITY OF NEWBURYPORT



IN CITY COUNCIL

ORDERED:

July 10, 2023

WHEREAS, on September 27, 2022, the City Council, upon the recommendation of the Community Preservation Committee, appropriated \$2,574,000 by and through ORDR00355_05_09_2022, and

WHEREAS, this appropriation was subject to a final plan being presented to the Council for approval, and

WHEREAS, the plan is in final form without any substantial changes anticipated and is attached hereto and incorporated herewith and marked "Exhibit A".

NOW, THEREFORE, THE CITY COUNCIL OF THE CITY OF NEWBURYPORT hereby approves said plan in accordance with the requirement of ORDR00355_05_09_2022 for the purpose of payment of costs of the Bartlet Mall Frog Pond Improvements project, including the payment of all costs incidental and related thereto.

Councillor Sharif I. Zeid

In City Council July 10, 2023:

Motion to refer to Community Services and COTW by Councillor McCauley, seconded by Councillor Zeid. So voted.

In City Council December 11, 2023:

Motion to collectively invoke Rule 7H for ORDR00515 and ORDR00474 by Councillor McCauley, seconded by Councillor Preston. 10 yes, 1 present (Lane). So voted.

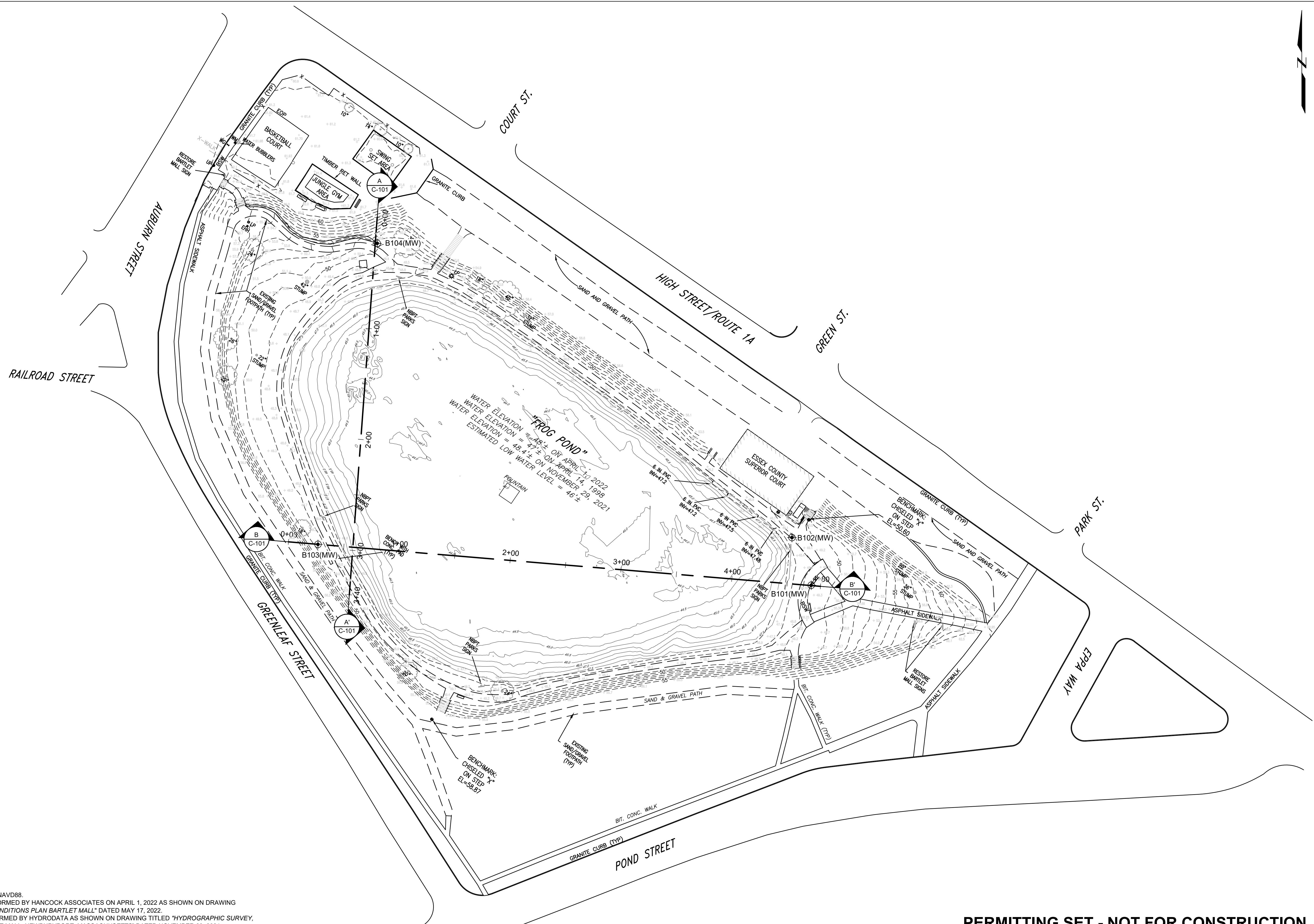

- LEGEND:**
- MONITORING WELL, GEI 2021
 - SEWER MANHOLE
 - DRAIN MANHOLE
 - CATCH BASIN
 - LIGHT POLE
 - UTILITY POLE
 - HYDRANT
 - SIGN
 - TRAFFIC SIGNAL
 - DRINKING FOUNTAIN
 - TC TOP OF CURB
 - BC BOTTOM OF CURB
 - BIT. BITUMINOUS
 - CONC. CONCRETE
 - CLF CHAIN LINK FENCE
 - DECIDUOUS TREE
 - CHAIN LINK FENCE

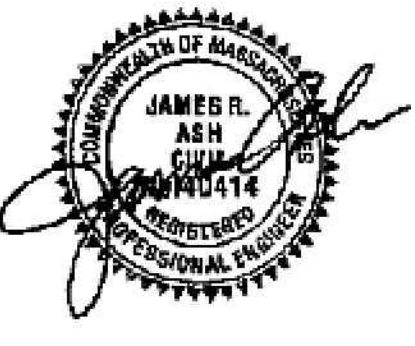

SOURCE:

- ELEVATION DATUM: NAVD88.
- FIELD SURVEY PERFORMED BY HANCOCK ASSOCIATES ON APRIL 1, 2022 AS SHOWN ON DRAWING TITLED "EXISTING CONDITIONS PLAN BARTLET MALL" DATED MAY 17, 2022.
- BATHYMETRY PERFORMED BY HYDRODATA AS SHOWN ON DRAWING TITLED "HYDROGRAPHIC SURVEY, FROG POND, BARTLET MALL, NEWBURYPORT, MASSACHUSETTS" DATED NOVEMBER 29, 2021.

PERMITTING SET - NOT FOR CONSTRUCTION

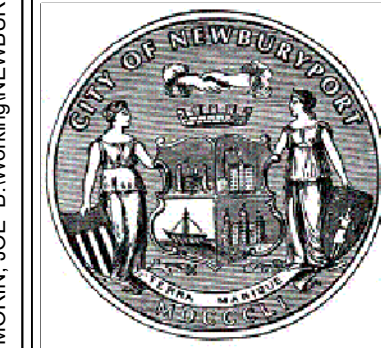

CITY OF NEWBURYPORT
60 PLEASANT STREET
NEWBURYPORT, MA 01950



Rev No	Date	Drawn	Chkd	Description
REVI	06/16/23	D.E.	K.W.	DRAWING SET FOR NOTICE OF INTENT
REVO	04/14/23	D.E.	K.W.	DRAWING SET FOR NOTICE OF INTENT
Revisions				

Designed By:
D.E.
Checked By:
K.W.
Date:
04-14-2023

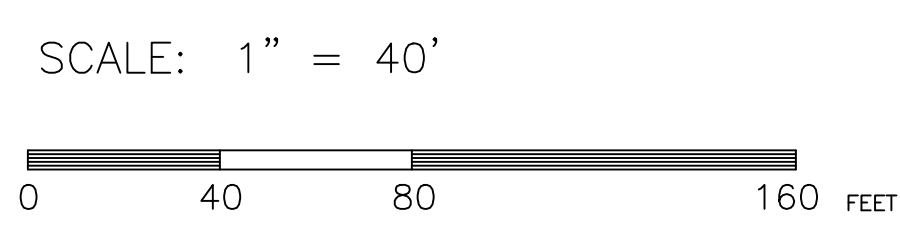

BARTLET MALL RESTORATION PROJECT
EXISTING CONDITIONS

Sheet No.
C-100

MORIN, JOE B. Working\NEWBURYPORT, MA, CITY OF\21013333, Bartlett Mall Frog Pond\00_CAD\Design\GISD\Permit\C-100_2101333-EC.dwg - 6/19/2023

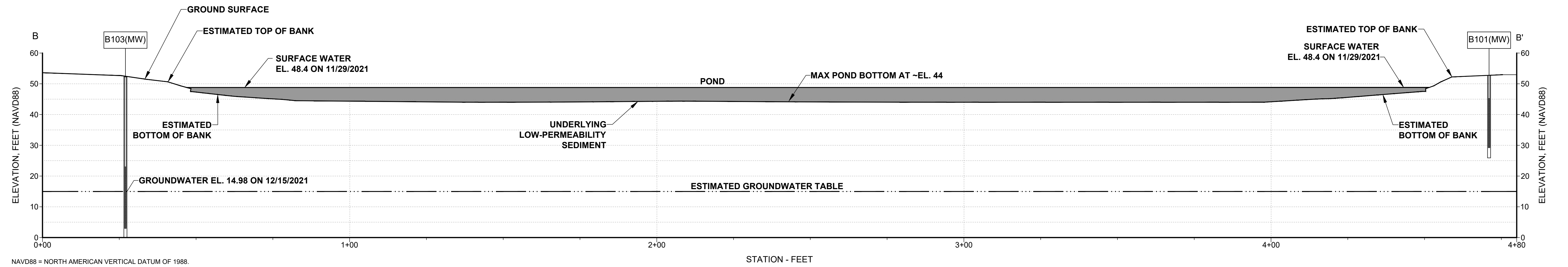
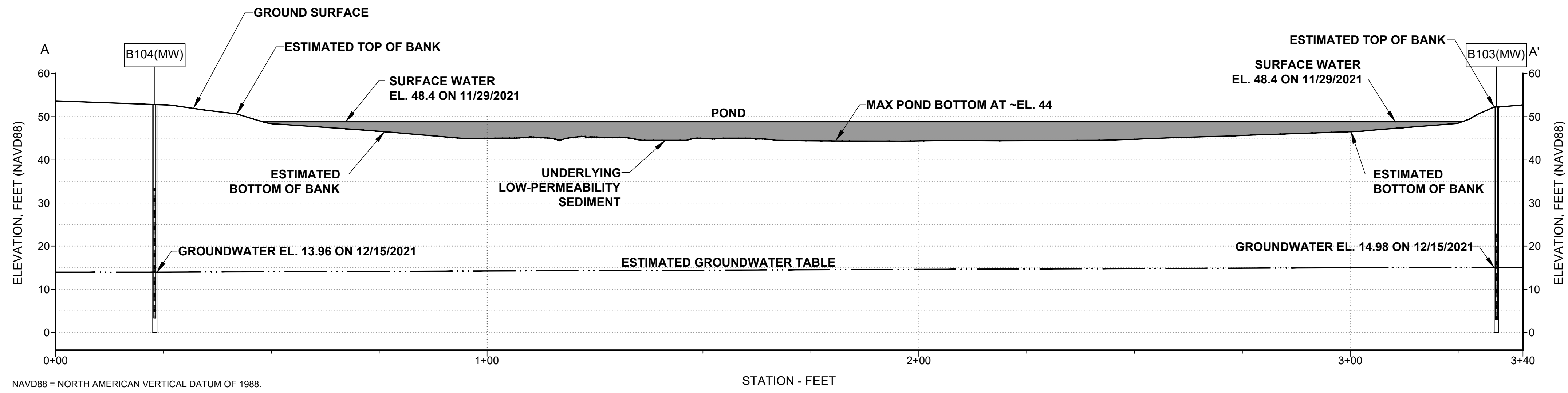

MORIN, JOE B. Working\NEWBURYPORT MA, CITY OF 21013333, Bartlett Mall Frog Pond\00_CAD\Design\Civil\BSP\Permit\101_21013333-EC-Sections.dwg - 01/19/2023

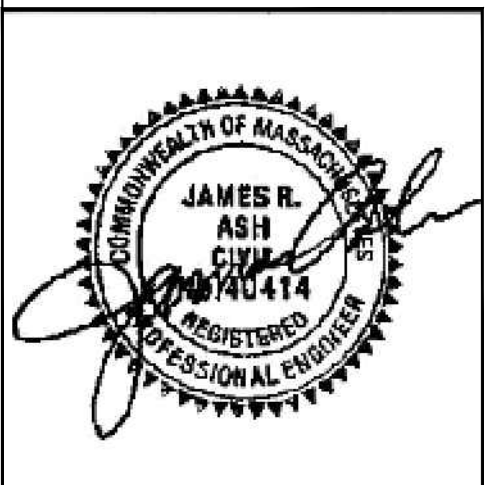

PERMITTING SET - NOT FOR CONSTRUCTION

	CITY OF NEWBURYPORT 60 PLEASANT STREET NEWBURYPORT, MA 01950	GEI Consultants GEI CONSULTANTS, INC. 400 UNICORN PARK DRIVE WOBURN, MA 01801 (781)721-4000	Designed By: D.E.	BARTLETT MALL RESTORATION PROJECT EXISTING CONDITIONS SECTIONS	Sheet No. C-101																				
			Checked By: K.W.			Date: 04-14-2023																			
<table border="1" style="width: 100%; border-collapse: collapse;"> <thead> <tr> <th>Rev No</th> <th>Date</th> <th>Drawn</th> <th>Chkd</th> <th>Description</th> </tr> </thead> <tbody> <tr> <td>REV1</td> <td>06/16/23</td> <td>D.E.</td> <td>K.W.</td> <td>DRAWING SET FOR NOTICE OF INTENT</td> </tr> <tr> <td>REVO</td> <td>04/14/23</td> <td>D.E.</td> <td>K.W.</td> <td>DRAWING SET FOR NOTICE OF INTENT</td> </tr> <tr> <td colspan="5" style="text-align: center;">Revisions</td> </tr> </tbody> </table>			Rev No	Date	Drawn	Chkd	Description	REV1	06/16/23	D.E.	K.W.	DRAWING SET FOR NOTICE OF INTENT	REVO	04/14/23	D.E.	K.W.	DRAWING SET FOR NOTICE OF INTENT	Revisions							
Rev No	Date	Drawn	Chkd	Description																					
REV1	06/16/23	D.E.	K.W.	DRAWING SET FOR NOTICE OF INTENT																					
REVO	04/14/23	D.E.	K.W.	DRAWING SET FOR NOTICE OF INTENT																					
Revisions																									

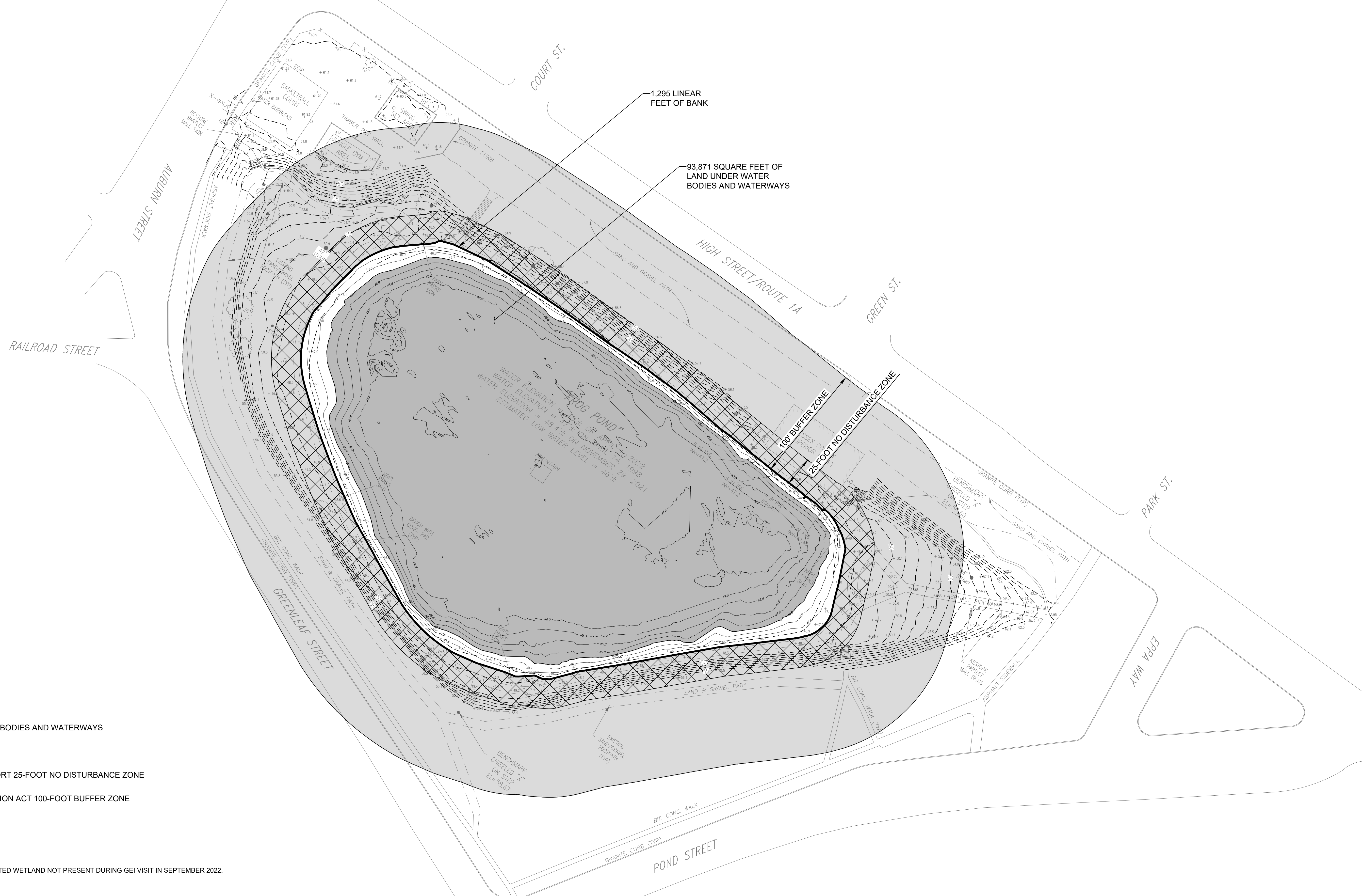

- LEGEND:**
- APPROXIMATE LAND UNDER WATER BODIES AND WATERWAYS
 - TOP OF BANK
 - APPROXIMATE CITY OF NEWBURYPORT 25-FOOT NO DISTURBANCE ZONE
 - APPROXIMATE WETLANDS PROTECTION ACT 100-FOOT BUFFER ZONE

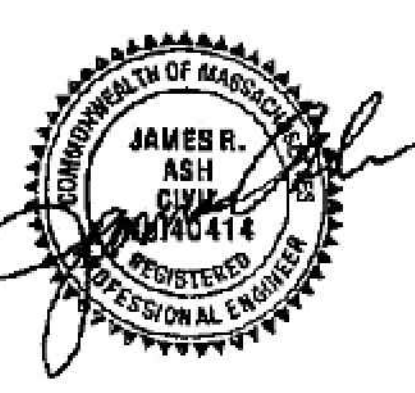

NOTES:
 1. BORDERING VEGETATED WETLAND NOT PRESENT DURING GEI VISIT IN SEPTEMBER 2022.

SOURCE:
 1. ELEVATION DATUM: NAVD88.
 2. FIELD SURVEY PERFORMED BY HANCOCK ASSOCIATES ON APRIL 1, 2022 AS SHOWN ON DRAWING TITLED "EXISTING CONDITIONS PLAN BARTLET MALL" DATED MAY 17, 2022.
 3. BATHYMETRY PERFORMED BY HYDRODATA AS SHOWN ON DRAWING TITLED "HYDROGRAPHIC SURVEY, FROG POND, BARTLET MALL, NEWBURYPORT, MASSACHUSETTS" DATED NOVEMBER 29, 2021.

PERMITTING SET - NOT FOR CONSTRUCTION

	CITY OF NEWBURYPORT 60 PLEASANT STREET NEWBURYPORT, MA 01950	 GEI CONSULTANTS, INC. 400 UNICORN PARK DRIVE WOBURN, MA 01801 (781)721-4000	<table border="1" style="width: 100%; border-collapse: collapse;"> <tr> <th>Rev No</th> <th>Date</th> <th>Drawn</th> <th>Chkd</th> <th>Description</th> </tr> <tr> <td>REVI</td> <td>06/16/23</td> <td>D.E.</td> <td>K.W.</td> <td>DRAWING SET FOR NOTICE OF INTENT</td> </tr> <tr> <td>REVO</td> <td>04/14/23</td> <td>D.E.</td> <td>K.W.</td> <td>DRAWING SET FOR NOTICE OF INTENT</td> </tr> <tr> <td colspan="5" style="text-align: center;">Revisions</td> </tr> </table>	Rev No	Date	Drawn	Chkd	Description	REVI	06/16/23	D.E.	K.W.	DRAWING SET FOR NOTICE OF INTENT	REVO	04/14/23	D.E.	K.W.	DRAWING SET FOR NOTICE OF INTENT	Revisions					Designed By: D.E. Checked By: K.W. Date: 04-14-2023	SCALE: 1" = 40' 	BARTLET MALL RESTORATION PROJECT RESOURCE AREAS	Sheet No. C-102
	Rev No		Date	Drawn	Chkd	Description																					
REVI	06/16/23	D.E.	K.W.	DRAWING SET FOR NOTICE OF INTENT																							
REVO	04/14/23	D.E.	K.W.	DRAWING SET FOR NOTICE OF INTENT																							
Revisions																											

MORIN, JOE B. WorkingNEWBURYPORT, MA, CITY OF 2101333, Resource Areas.dwg - 6/15/2023

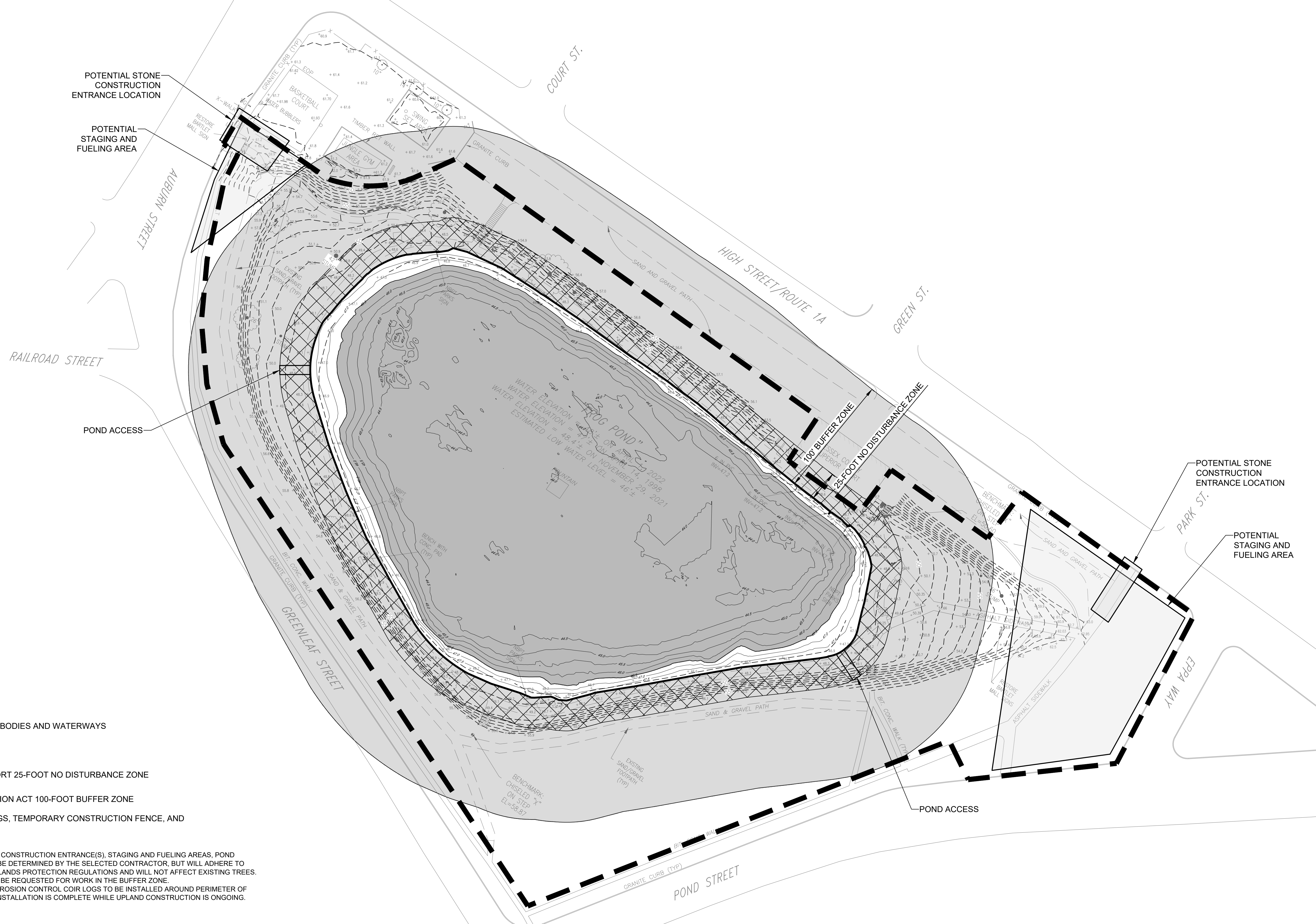

- LEGEND:**
- APPROXIMATE LAND UNDER WATER BODIES AND WATERWAYS
 - TOP OF BANK
 - APPROXIMATE CITY OF NEWBURYPORT 25-FOOT NO DISTURBANCE ZONE
 - APPROXIMATE WETLANDS PROTECTION ACT 100-FOOT BUFFER ZONE
 - 6-INCH EROSION CONTROL COIR LOGS, TEMPORARY CONSTRUCTION FENCE, AND LIMIT OF WORK

- NOTES:**
1. FINAL LOCATIONS OF CONSTRUCTION ENTRANCE(S), STAGING AND FUELING AREAS, POND ACCESSES, ETC. TO BE DETERMINED BY THE SELECTED CONTRACTOR, BUT WILL ADHERE TO NEWBURYPORT WETLANDS PROTECTION REGULATIONS AND WILL NOT AFFECT EXISTING TREES. LETTER PERMIT WILL BE REQUESTED FOR WORK IN THE BUFFER ZONE.
 2. ADDITIONAL 6-INCH EROSION CONTROL COIR LOGS TO BE INSTALLED AROUND PERIMETER OF POND AFTER LINER INSTALLATION IS COMPLETE WHILE UPLAND CONSTRUCTION IS ONGOING.

- SOURCE:**
1. ELEVATION DATUM: NAVD88.
 2. FIELD SURVEY PERFORMED BY HANCOCK ASSOCIATES ON APRIL 1, 2022 AS SHOWN ON DRAWING TITLED "EXISTING CONDITIONS PLAN BARTLET MALL" DATED MAY 17, 2022.
 3. BATHYMETRY PERFORMED BY HYDRODATA AS SHOWN ON DRAWING TITLED "HYDROGRAPHIC SURVEY, FROG POND, BARTLET MALL, NEWBURYPORT, MASSACHUSETTS" DATED NOVEMBER 29, 2021.

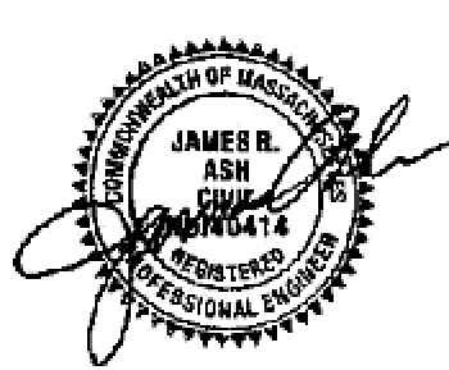

PERMITTING SET - NOT FOR CONSTRUCTION

	CITY OF NEWBURYPORT 60 PLEASANT STREET NEWBURYPORT, MA 01950	 GEI CONSULTANTS, INC. 400 UNICORN PARK DRIVE WOBURN, MA 01801 (781)721-4000	Designed By: D.E.	SCALE: 1" = 40' 	BARTLET MALL RESTORATION PROJECT STAGING AND EROSION CONTROL PLAN	Sheet No. C-103																
	<table border="1" style="width: 100%; border-collapse: collapse;"> <thead> <tr> <th style="width: 5%;">Rev No</th> <th style="width: 10%;">Date</th> <th style="width: 10%;">Drawn</th> <th style="width: 10%;">Chkd</th> <th style="width: 60%;">Description</th> </tr> </thead> <tbody> <tr> <td>REVI</td> <td>06/16/23</td> <td>D.E.</td> <td>K.W.</td> <td>DRAWING SET FOR NOTICE OF INTENT</td> </tr> <tr> <td>REVO</td> <td>04/14/23</td> <td>D.E.</td> <td>K.W.</td> <td>DRAWING SET FOR NOTICE OF INTENT</td> </tr> <tr> <td colspan="5" style="text-align: center;">Revisions</td> </tr> </tbody> </table>		Rev No		Date	Drawn	Chkd	Description	REVI	06/16/23	D.E.	K.W.	DRAWING SET FOR NOTICE OF INTENT	REVO	04/14/23	D.E.	K.W.	DRAWING SET FOR NOTICE OF INTENT	Revisions			
Rev No	Date	Drawn	Chkd	Description																		
REVI	06/16/23	D.E.	K.W.	DRAWING SET FOR NOTICE OF INTENT																		
REVO	04/14/23	D.E.	K.W.	DRAWING SET FOR NOTICE OF INTENT																		
Revisions																						

MORIN, JOE B. WorkingNEWBURYPORT MA CITY OF2101333 Bartlett Mall Frog Pond00_CADDDesign/ChisledPermitC-103 2101333 Staging and Erosion Control Plan.dwg - 6/19/2023

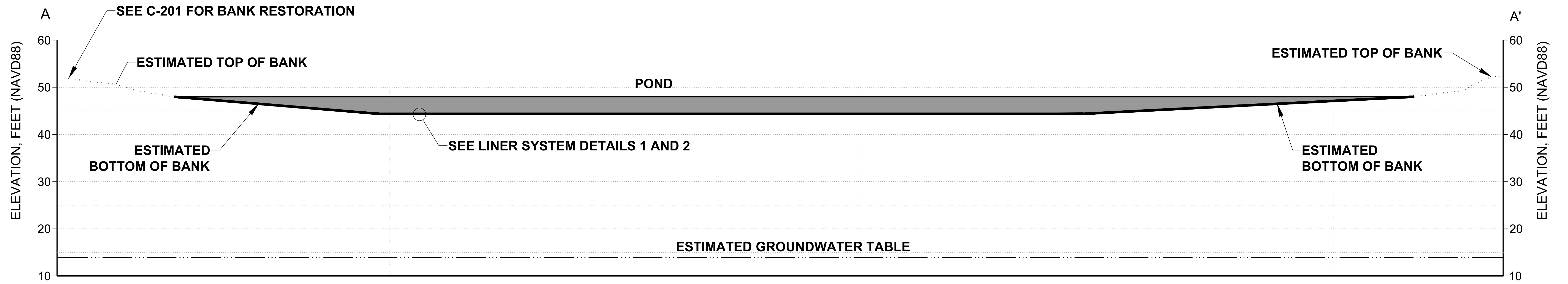

NAVD88 = NORTH AMERICAN VERTICAL DATUM OF 1988.

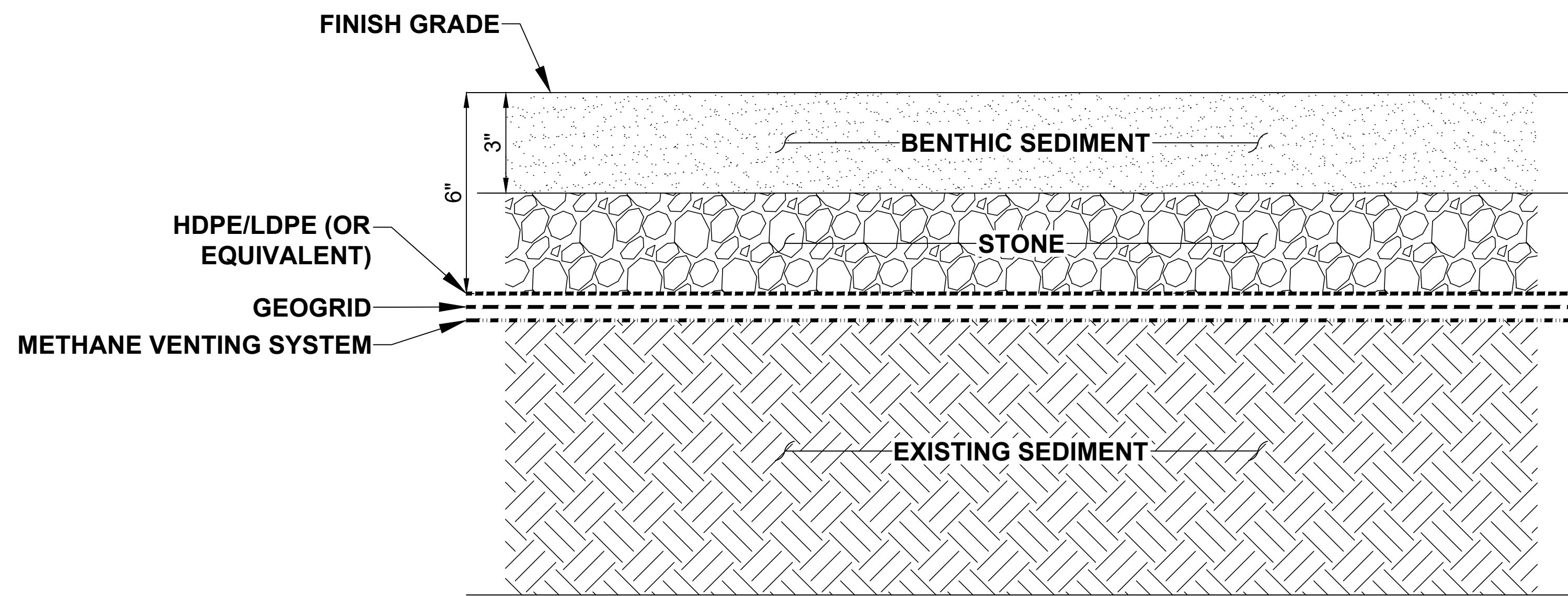

1 TYPICAL DETAIL
C-104 LINER SYSTEM DETAIL NO SCALE

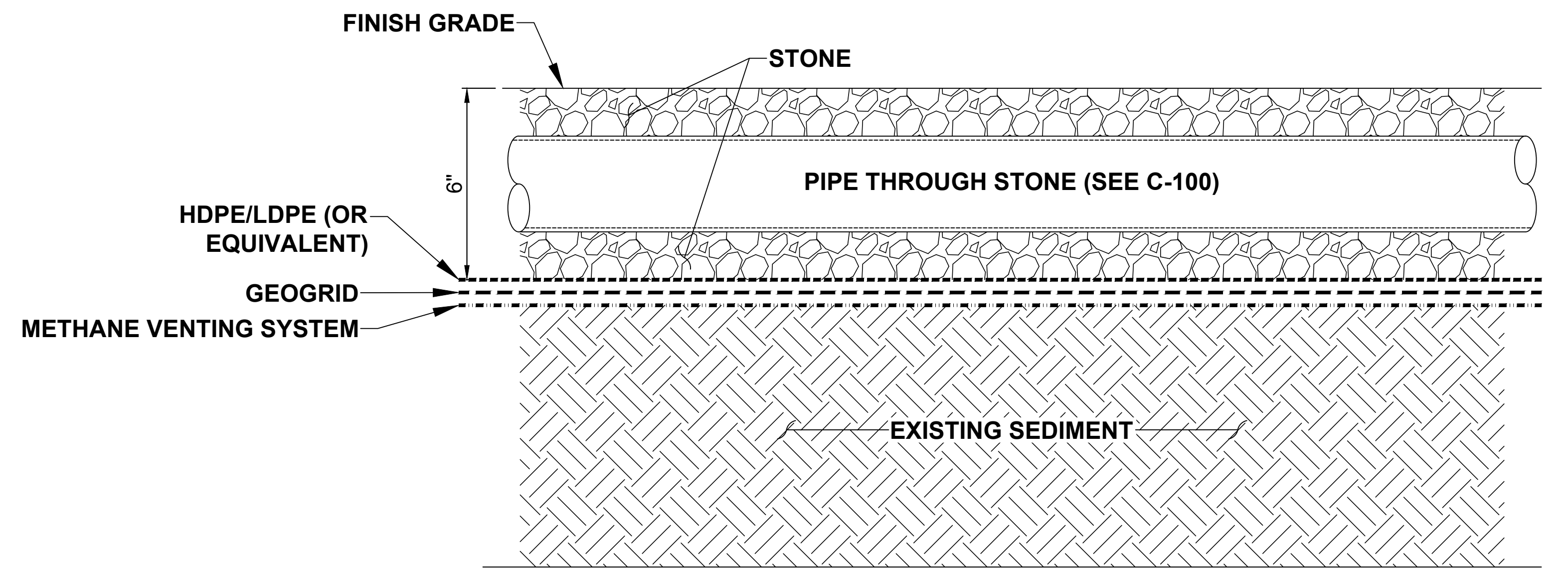

2 TYPICAL DETAIL
C-104 LINER SYSTEM DETAIL AROUND WATER QUALITY PIPES NO SCALE

MORIN, JOE B. WorkingNEWBURYPORT MA, CITY OF 2101333, Bartlett Mall Frog Pond00_CADDesign\GISD\Permit\C-200 2101333-Liner.dwg - 01/19/2023

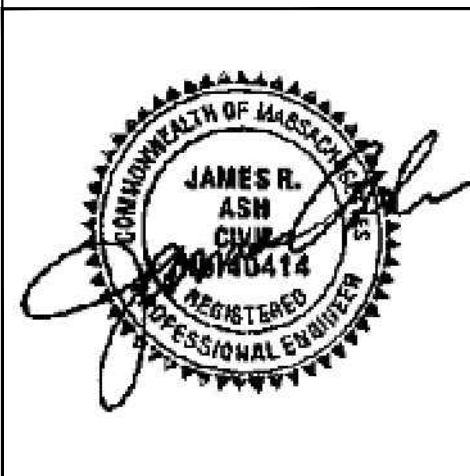

PERMITTING SET - NOT FOR CONSTRUCTION

<p>CITY OF NEWBURYPORT 60 PLEASANT STREET NEWBURYPORT, MA 01950</p>	<p>GEI CONSULTANTS, INC. 400 UNICORN PARK DRIVE WOBURN, MA 01801 (781)721-4000</p>	<table border="1"> <tr> <th>Rev No</th> <th>Date</th> <th>Drawn</th> <th>Chkd</th> <th>Description</th> </tr> <tr> <td>REVI</td> <td>06/16/23</td> <td>D.E.</td> <td>K.W.</td> <td>DRAWING SET FOR NOTICE OF INTENT</td> </tr> <tr> <td>REVO</td> <td>04/14/23</td> <td>D.E.</td> <td>K.W.</td> <td>DRAWING SET FOR NOTICE OF INTENT</td> </tr> <tr> <td colspan="5">Revisions</td> </tr> </table>	Rev No	Date	Drawn	Chkd	Description	REVI	06/16/23	D.E.	K.W.	DRAWING SET FOR NOTICE OF INTENT	REVO	04/14/23	D.E.	K.W.	DRAWING SET FOR NOTICE OF INTENT	Revisions					<p>Designed By: D.E.</p> <p>Checked By: K.W.</p> <p>Date: 04-14-2023</p>	<p>BARTLETT MALL RESTORATION PROJECT</p> <p>LINER SYSTEM SECTION AND DETAILS</p>	<p>Sheet No. C-200</p>
		Rev No	Date	Drawn	Chkd	Description																			
REVI	06/16/23	D.E.	K.W.	DRAWING SET FOR NOTICE OF INTENT																					
REVO	04/14/23	D.E.	K.W.	DRAWING SET FOR NOTICE OF INTENT																					
Revisions																									

FROM POND AND/OR BEDROCK WELL

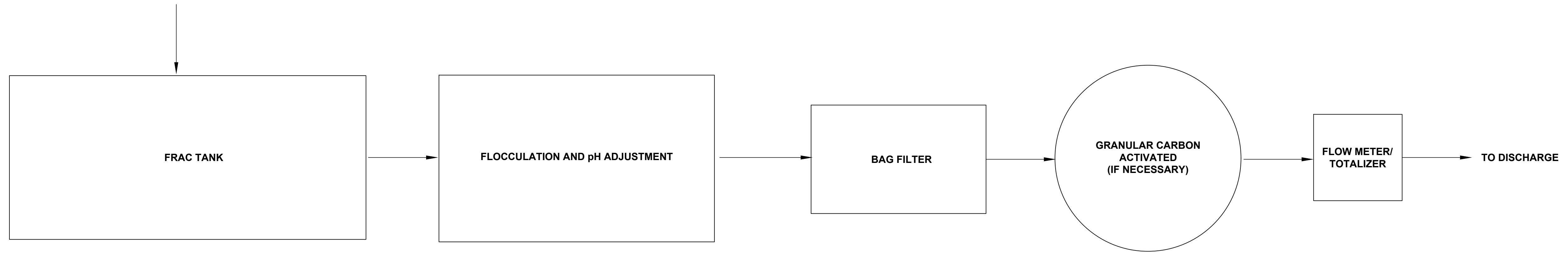

PROCESS FLOW DIAGRAM
NO SCALE

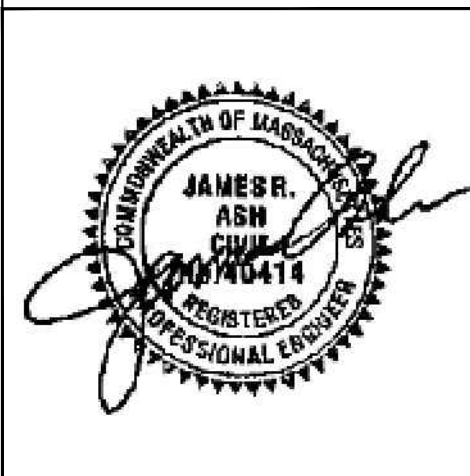

NOTES:
1. NPDES = NATIONAL POLLUTANT DISCHARGE ELIMINATION SYSTEM.

PERMITTING SET - NOT FOR CONSTRUCTION

MORIN, JOE B. Working\NEWBURYPORT MA_CITY OF 2101333_Bartlett Mall Frog Pond\00_CADD\Design\Civil\ISD\Permit\C-300_2101333-Flow.dwg - 6/15/2023

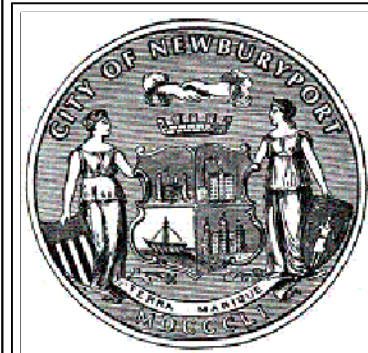

CITY OF NEWBURYPORT
60 PLEASANT STREET
NEWBURYPORT, MA 01950



Rev No	Date	Drawn	Chkd	Description
REVI	06/16/23	D.E.	K.W.	DRAWING SET FOR NOTICE OF INTENT
REVO	04/14/23	D.E.	K.W.	DRAWING SET FOR NOTICE OF INTENT
Revisions				

Designed By:
D.E.
Checked By:
K.W.
Date:
04-14-2023

**BARTLET MALL RESTORATION PROJECT
NPDES WATER TREATMENT
SYSTEM PROCESS FLOW
DIAGRAM**

Sheet No.

C-300

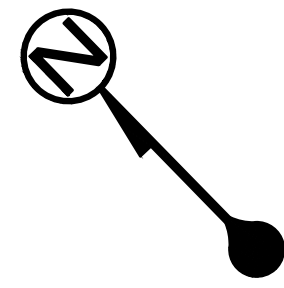

LEGEND

- CRUSHED STONE PATH
- FLEXIPAVE WALKWAY
- VEGETATED PERIMETER
- GRANITE SEAT-HEIGHT BLOCKS
- PROPOSED POND ACCESS POINT
- BEDROCK WELL LINE
- DOMESTIC WATER LINE
- ELECTRICAL SERVICE
- DISCHARGE AND AERATION LINE
- RECIRCULATED WATER LINE
- PUMP INTAKE PIPE
- DRYWELL DRAIN PIPE
- SURFACE WATER (APPROXIMATE)

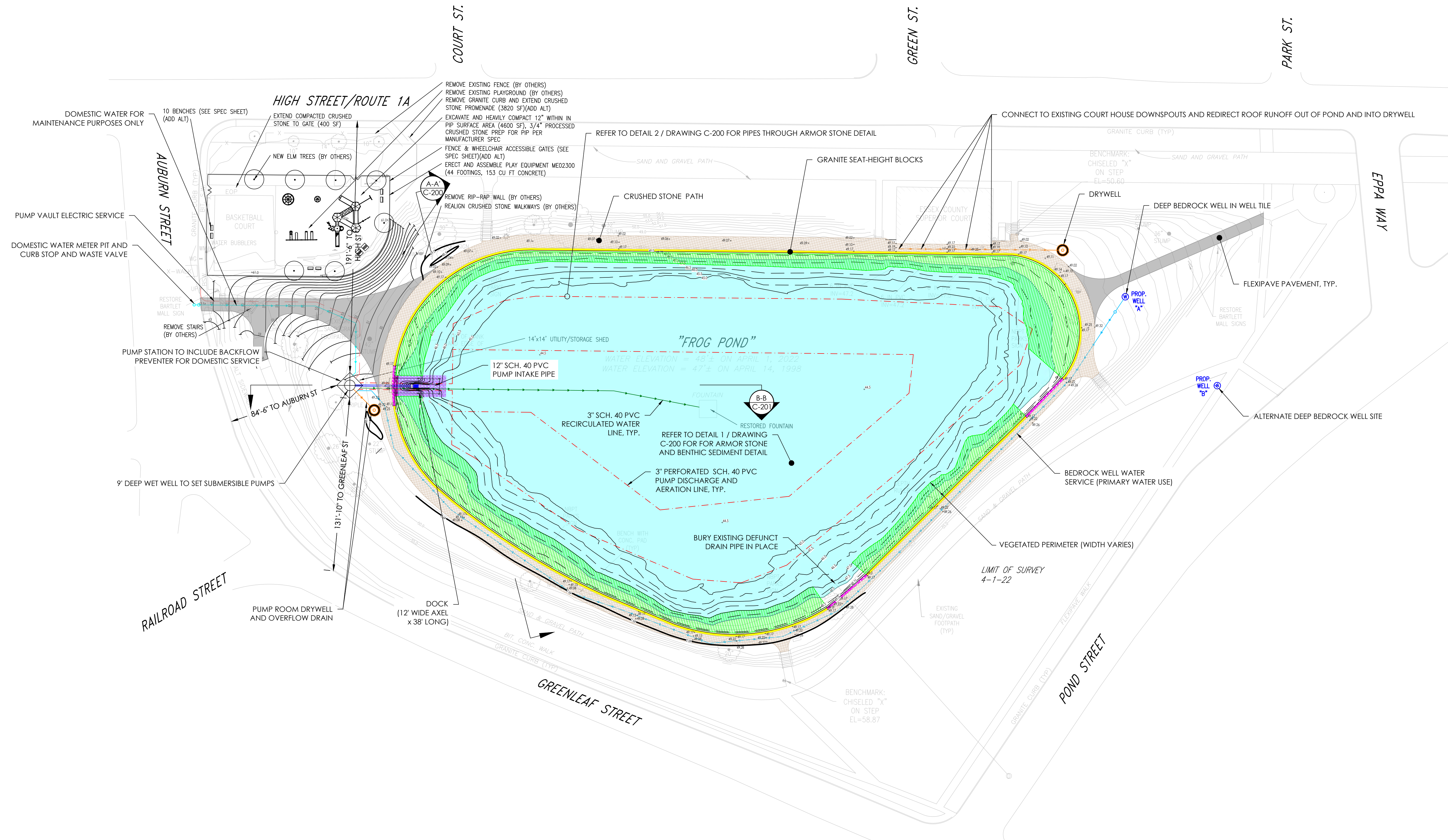

DESIGN BY:

AQUEOUS CONSULTANTS, LLC
 1 Dundee Park Drive, Suite 10
 Andover, MA 01810
 (978) 470-1695
 www.aqueous.net

6/19/23

PERMITTING SET - NOT FOR CONSTRUCTION

<p>CITY OF NEWBURYPORT 60 PLEASANT STREET NEWBURYPORT, MA 01950</p>	REV 1/6/19/23	AEH	MI		DRAWING SET FOR NOTICE OF INTENT	Designed By: A. Hammond	<p>SCALE: PLAN Scale: 1" = 40'</p>	<p>BARTLET MALL RESTORATION PROJECT PROPOSED FINAL CONDITIONS</p>	Sheet No. C-104
	REV 0/4/14/23	AEH	MI		DRAWING SET FOR NOTICE OF INTENT	Checked By: M. Igo			
	Rev No	Date	Drawn	Chkd	Description	Date: 4-14-2023			
						Revisions			

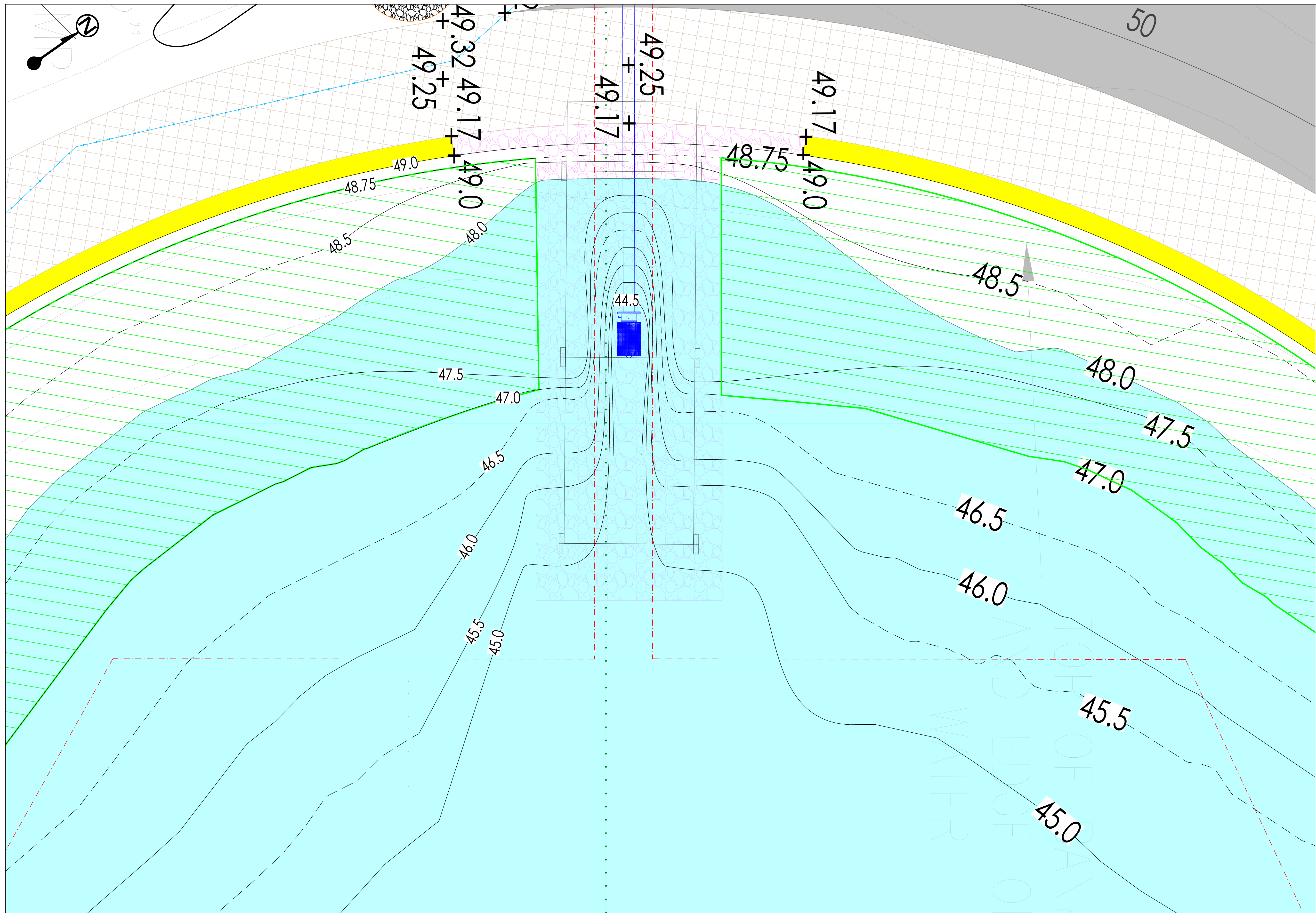

- LEGEND**
- CRUSHED STONE PATH
 - FLEXIPAVE WALKWAY
 - VEGETATED PERIMETER
 - GRANITE SEAT-HEIGHT BLOCKS
 - PROPOSED POND ACCESS POINT
 - BEDROCK WELL LINE
 - DOMESTIC WATER LINE
 - ELECTRICAL SERVICE
 - DISCHARGE AND AERATION LINE
 - RECIRCULATED WATER LINE
 - PUMP INTAKE PIPE
 - DRYWELL DRAIN PIPE
 - SURFACE WATER (APPROXIMATE)

DESIGN BY:

Aqueous

AQUEOUS CONSULTANTS, LLC
 1 Dundee Park Drive, Suite 10
 Andover, MA 01810
 (978) 470-1695
 www.aqueous.net

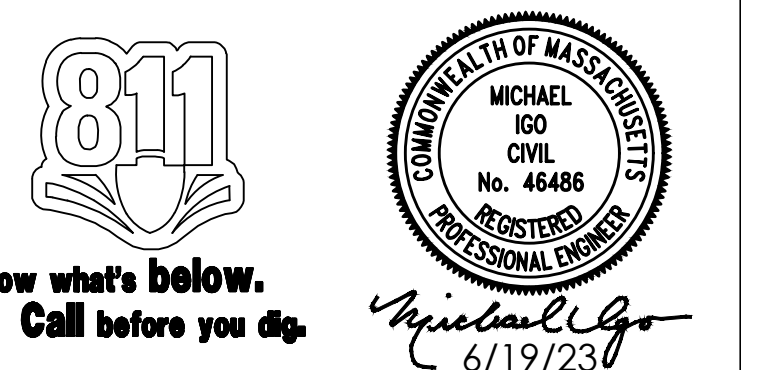

PERMITTING SET - NOT FOR CONSTRUCTION

<p>CITY OF NEWBURYPORT 60 PLEASANT STREET NEWBURYPORT, MA 01950</p>	<table border="1"> <tr> <td>REV 1</td> <td>6/19/23</td> <td>AEH</td> <td>MI</td> <td></td> </tr> <tr> <td>REV 0</td> <td>4/14/23</td> <td>AEH</td> <td>MI</td> <td></td> </tr> <tr> <th>Rev No</th> <th>Date</th> <th>Drawn</th> <th>Chkd</th> <th>Description</th> </tr> </table>	REV 1	6/19/23	AEH	MI		REV 0	4/14/23	AEH	MI		Rev No	Date	Drawn	Chkd	Description	<table border="1"> <tr> <td>Designed By:</td> <td>A. Hammond</td> </tr> <tr> <td>Checked By:</td> <td>M. Igo</td> </tr> <tr> <td>Date:</td> <td>4-14-2023</td> </tr> </table>	Designed By:	A. Hammond	Checked By:	M. Igo	Date:	4-14-2023	<p>SCALE: PLAN Scale: 1" = 4'</p>	<p>BARTLET MALL RESTORATION PROJECT</p> <p>PROPOSED FINAL CONDITIONS</p>	<p>Sheet No. C-104A</p>
	REV 1	6/19/23	AEH	MI																						
	REV 0	4/14/23	AEH	MI																						
Rev No	Date	Drawn	Chkd	Description																						
Designed By:	A. Hammond																									
Checked By:	M. Igo																									
Date:	4-14-2023																									
<table border="1"> <tr> <th>Rev No</th> <th>Date</th> <th>Drawn</th> <th>Chkd</th> <th>Description</th> </tr> <tr> <td> </td> <td> </td> <td> </td> <td> </td> <td> </td> </tr> </table>	Rev No	Date	Drawn	Chkd	Description						<p>Revisions</p>	<p>SCALE: PLAN Scale: 1" = 4'</p>	<p>BARTLET MALL RESTORATION PROJECT</p> <p>PROPOSED FINAL CONDITIONS</p>	<p>Sheet No. C-104A</p>												
Rev No	Date	Drawn	Chkd	Description																						
<p>Revisions</p>	<p>Revisions</p>	<p>SCALE: PLAN Scale: 1" = 4'</p>	<p>BARTLET MALL RESTORATION PROJECT</p> <p>PROPOSED FINAL CONDITIONS</p>	<p>Sheet No. C-104A</p>																						

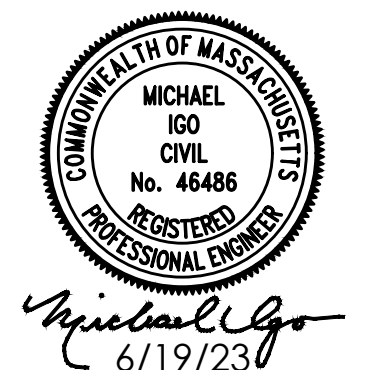
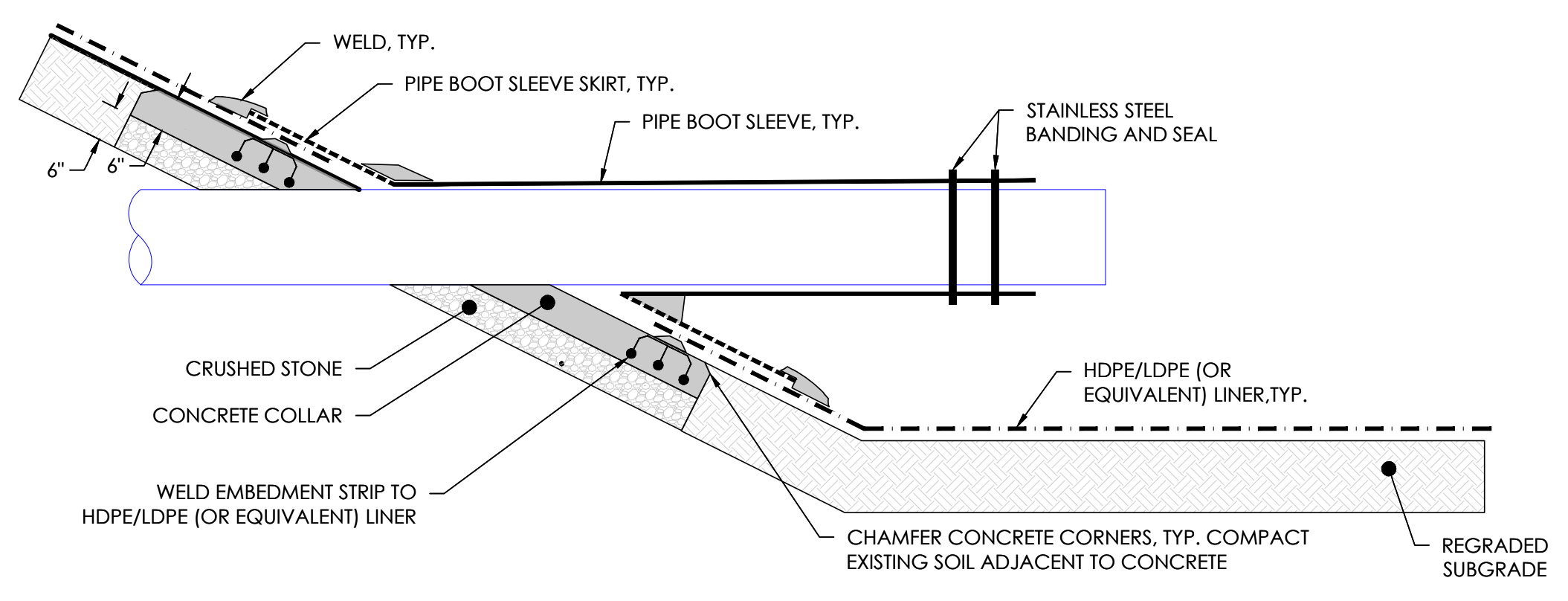
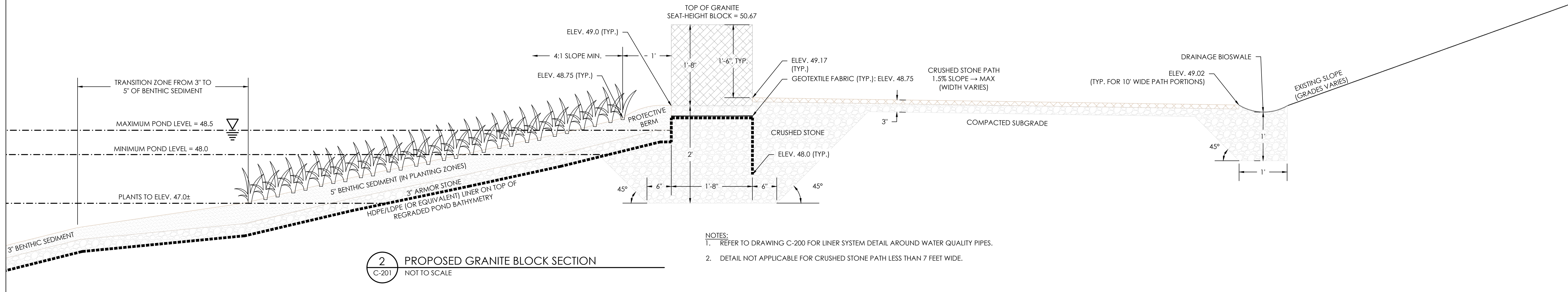
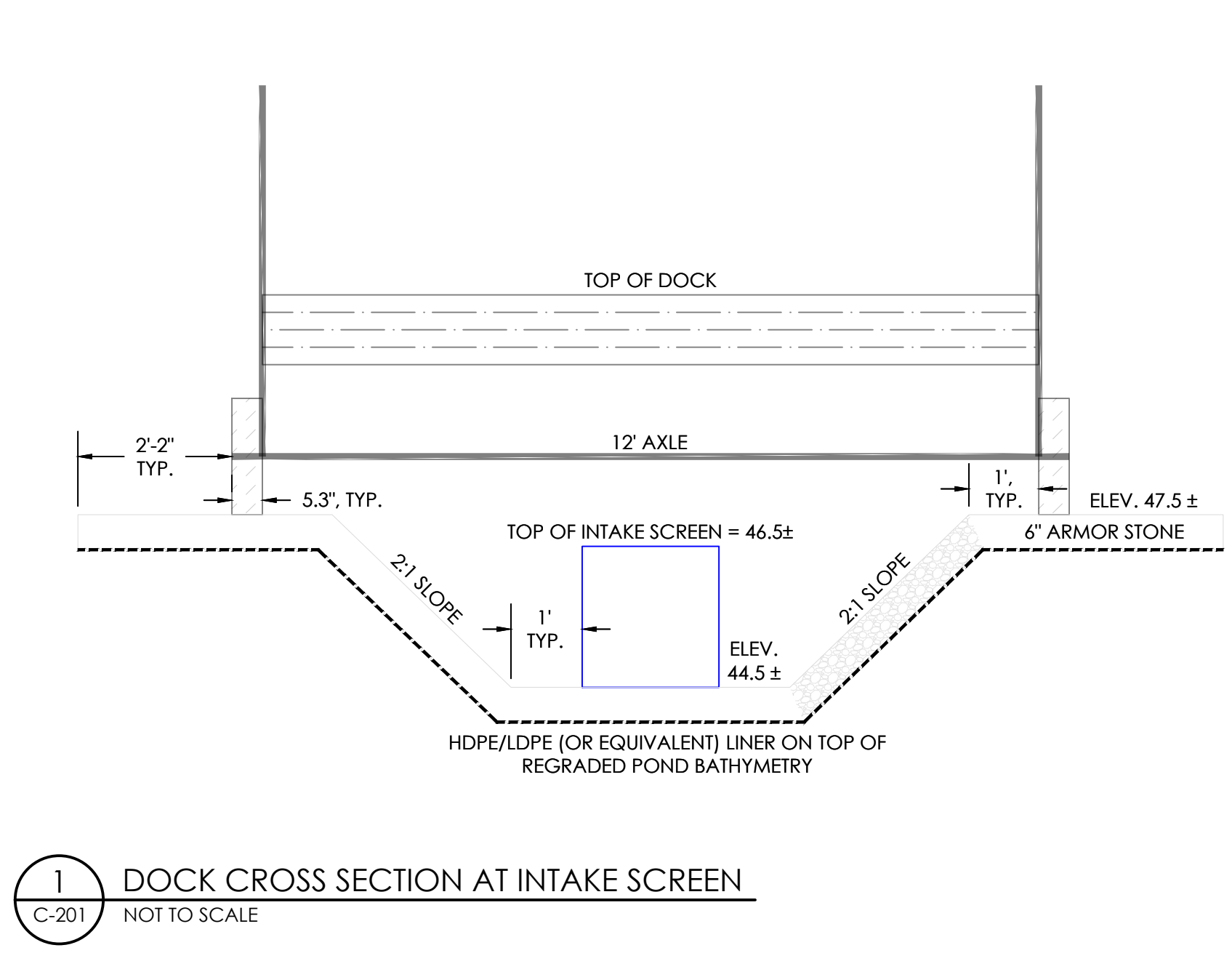
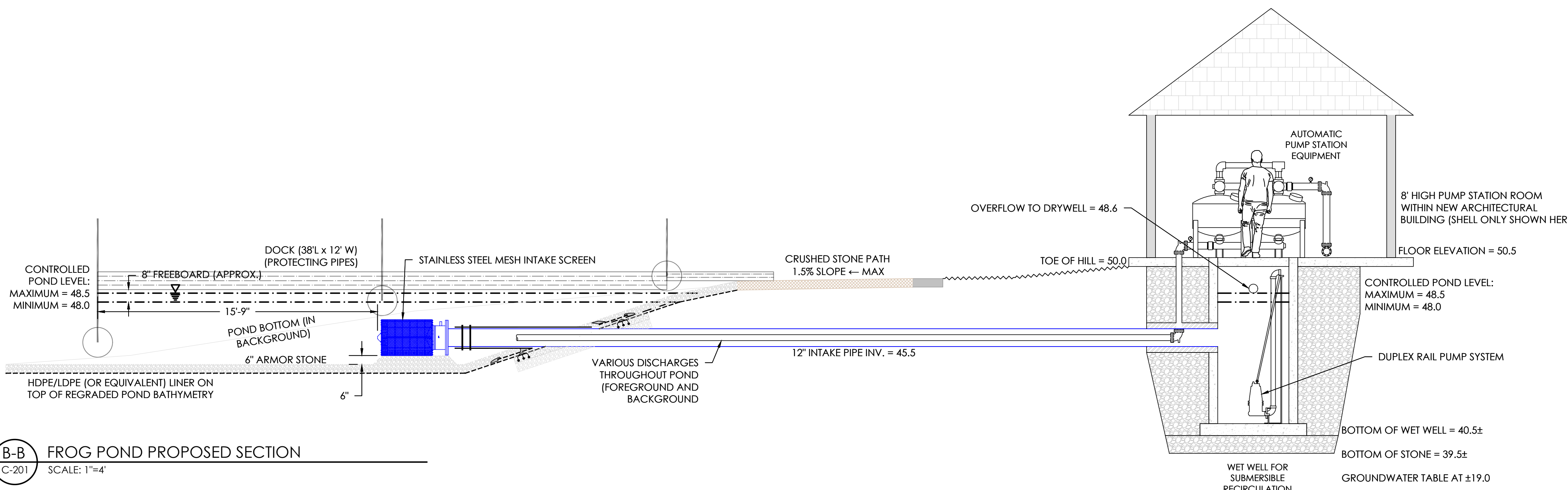

PERMITTING SET - NOT FOR CONSTRUCTION

<p>CITY OF NEWBURYPORT 60 PLEASANT STREET NEWBURYPORT, MA 01950</p>	<table border="1"> <tr> <td>REV</td> <td>16/19/23</td> <td>AEH</td> <td>MI</td> <td></td> </tr> <tr> <td>REV</td> <td>04/14/23</td> <td>AEH</td> <td>MI</td> <td></td> </tr> <tr> <td>Rev No</td> <td>Date</td> <td>Drawn</td> <td>Chkd</td> <td>Description</td> </tr> <tr> <td colspan="5" style="text-align: center;">Revisions</td> </tr> </table>	REV	16/19/23	AEH	MI		REV	04/14/23	AEH	MI		Rev No	Date	Drawn	Chkd	Description	Revisions					Designed By: A. Hammond Checked By: M. Igo Date: 4-14-2023	SCALE: SECTION Scale: 1" = 4' 	BARTLET MALL RESTORATION PROJECT CIVIL DETAILS - 1 Sheet No. C-201
	REV	16/19/23	AEH	MI																				
	REV	04/14/23	AEH	MI																				
Rev No	Date	Drawn	Chkd	Description																				
Revisions																								

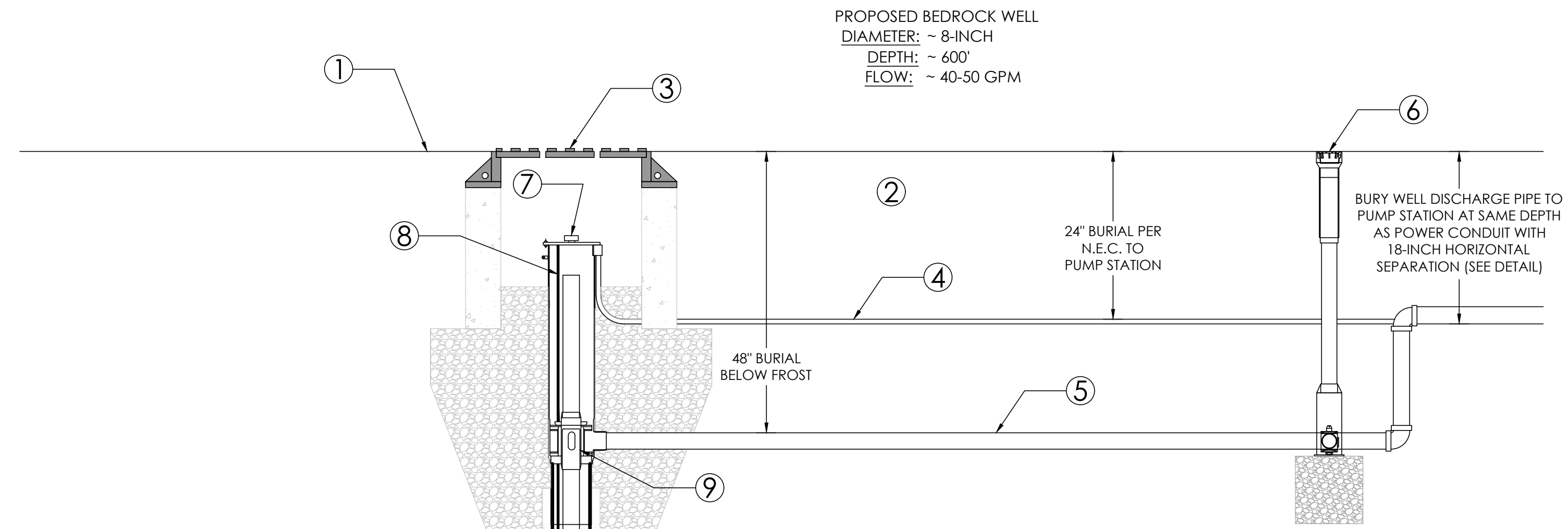

PROPOSED BEDROCK WELL
 DIAMETER: ~ 8-INCH
 DEPTH: ~ 600'
 FLOW: ~ 40-50 GPM

NOTE:
 1. BEDROCK WELL WATER TO BE TESTED
 TO EPA WATER QUALITY STANDARDS.

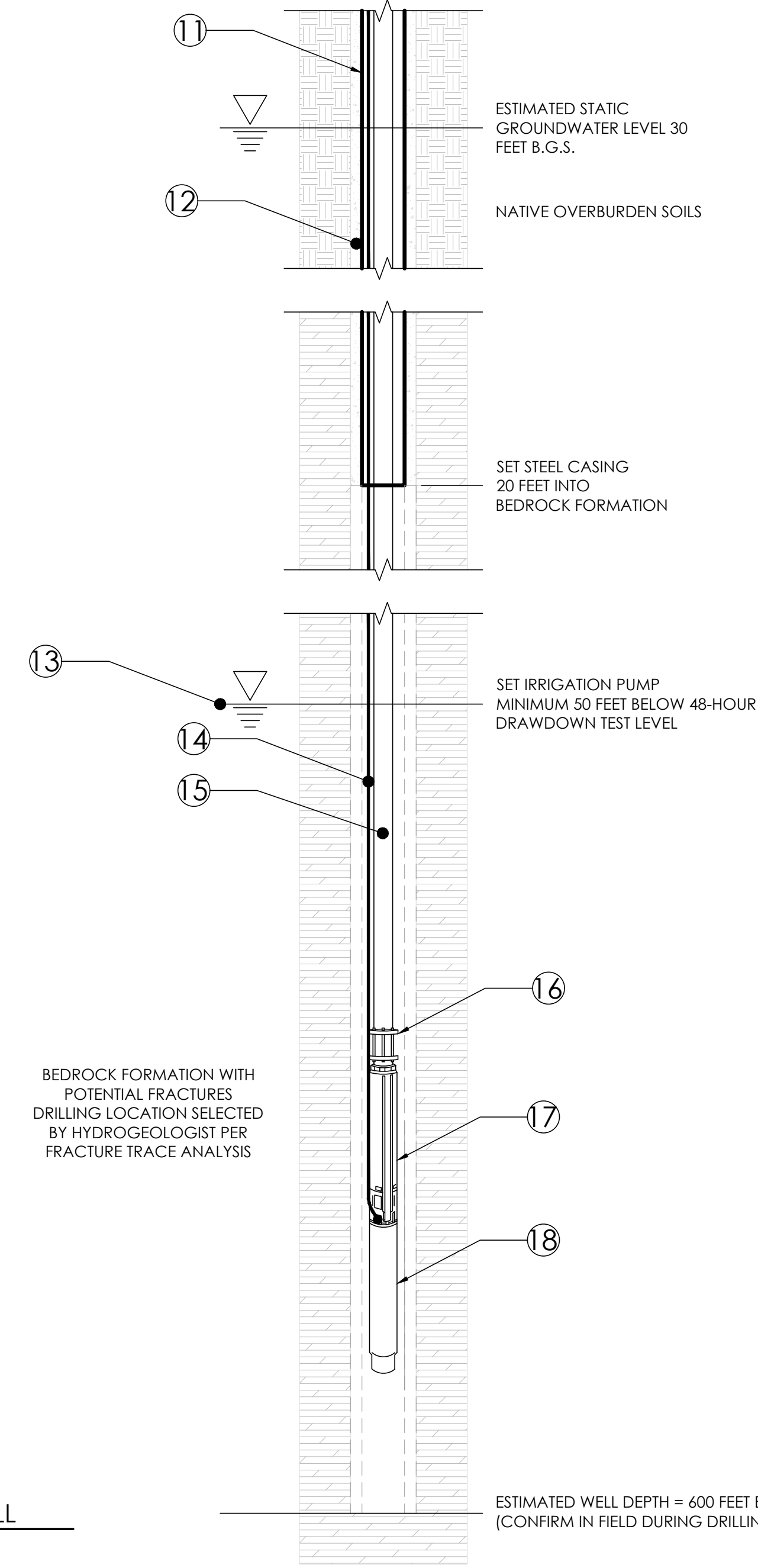

ITEM	PRODUCT
①	FINISH GRADE: FLEXIBLE PAVEMENT
②	COMPACTED SUBGRADE
③	30-INCH DIAMETER, 30-INCH DEEP CONCRETE WELL TILE AND VENTED CAST IRON COVER
④	1" CONDUIT (SCH. 40 PVC)
⑤	2" DISCHARGE PIPE TO PUMP STATION
⑥	STOP AND WASTE VALVE WITH 6-INCH GRAVEL SUMP FOR WINTERIZATION
⑦	WELL CASING SANITARY SEAL
⑧	8AWG SUBMERSIBLE POWER WIRE
⑨	PITLESS UNIT INTEGRAL SPOOL PIECE
⑩	WIRE SPACER
⑪	8-INCH SCHEDULE 40 PVC STEEL WELL CASING THREADED INTO PITLESS UNIT
⑫	NEAT CEMENT (5 BGS TO BOTTOM OF STEEL WELL CASING IN BEDROCK)
⑬	STEADY-STATE WELL WATER DRAWDOWN LEVEL AFTER 48 HOUR PUMP TEST
⑭	LIQUID LEVEL SENSOR WIRE IN WELL
⑮	2-INCH STEEL DISCHARGE DROP PIPE
⑯	CHECK VALVE
⑰	SUBMERSIBLE WELL PUMP WATER END WITH BEST EFFICIENCY POINT 40 - 50 GPM
⑱	SUBMERSIBLE WELL PUMP MOTOR, ESTIMATED 10 HORSEPOWER

4 DEEP BEDROCK WELL
 C-202 NOT TO SCALE

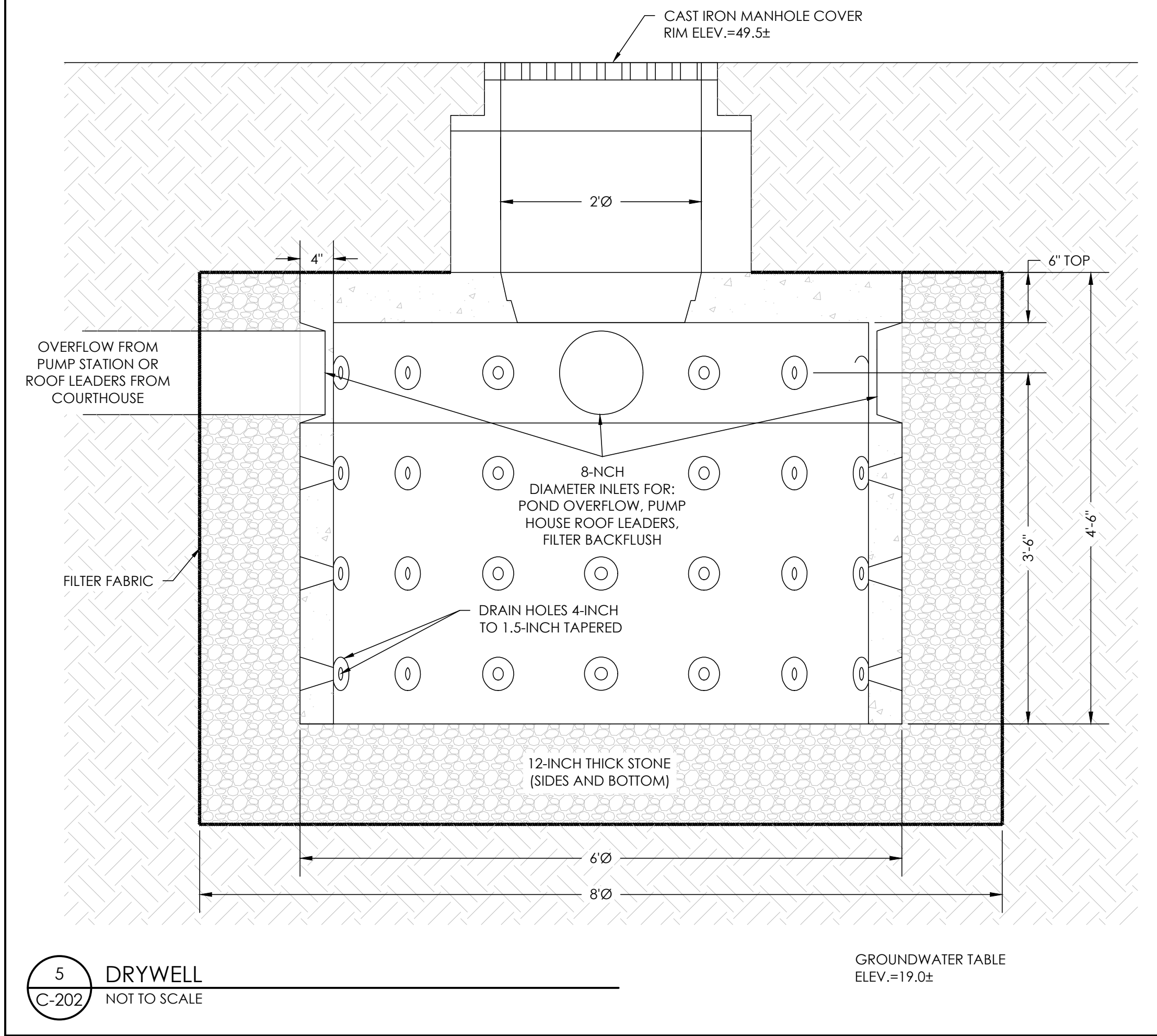

5 DRYWELL
 C-202 NOT TO SCALE

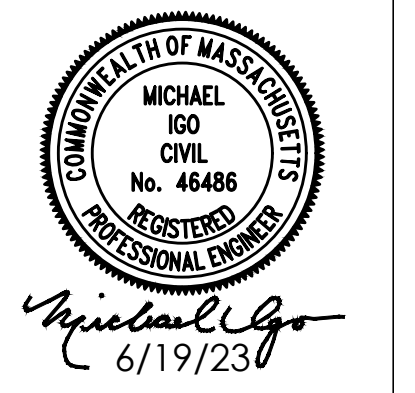

PERMITTING SET - NOT FOR CONSTRUCTION

<p>CITY OF NEWBURYPORT 60 PLEASANT STREET NEWBURYPORT, MA 01950</p>	<table border="1"> <tr> <th>Rev No</th> <th>Date</th> <th>Drawn</th> <th>Chkd</th> <th>Description</th> </tr> <tr> <td>REV 16/19/23</td> <td>AEH</td> <td>MI</td> <td></td> <td>DRAWING SET FOR NOTICE OF INTENT</td> </tr> <tr> <td>REV 04/14/23</td> <td>AEH</td> <td>MI</td> <td></td> <td>DRAWING SET FOR NOTICE OF INTENT</td> </tr> <tr> <td> </td> <td> </td> <td> </td> <td> </td> <td> </td> </tr> </table>	Rev No	Date	Drawn	Chkd	Description	REV 16/19/23	AEH	MI		DRAWING SET FOR NOTICE OF INTENT	REV 04/14/23	AEH	MI		DRAWING SET FOR NOTICE OF INTENT						Designed By: A. Hammond Checked By: M. Igo Date: 4-14-2023	SCALE: AS SHOWN	BARTLET MALL RESTORATION PROJECT CIVIL DETAILS - 2	Sheet No. C-202
	Rev No	Date	Drawn	Chkd	Description																				
REV 16/19/23	AEH	MI		DRAWING SET FOR NOTICE OF INTENT																					
REV 04/14/23	AEH	MI		DRAWING SET FOR NOTICE OF INTENT																					

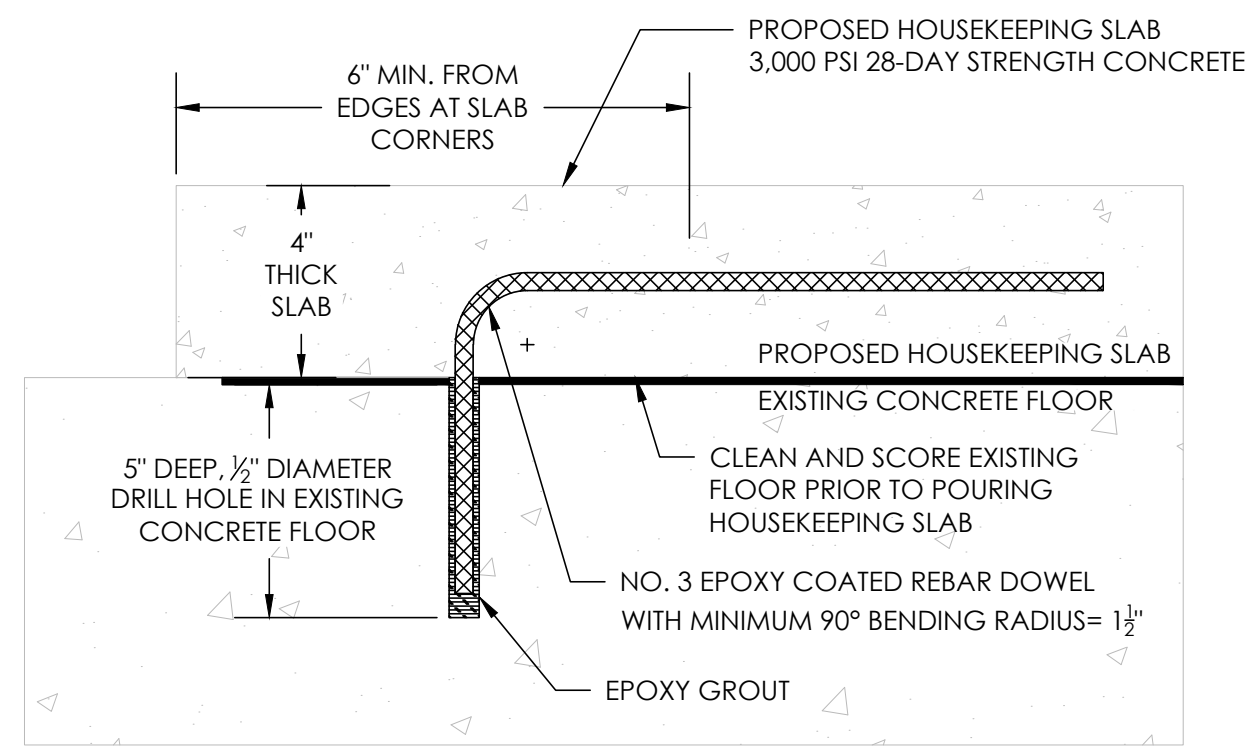

7 TYPICAL HOUSEKEEPING SLAB ELEVATION
C-203 NOT TO SCALE

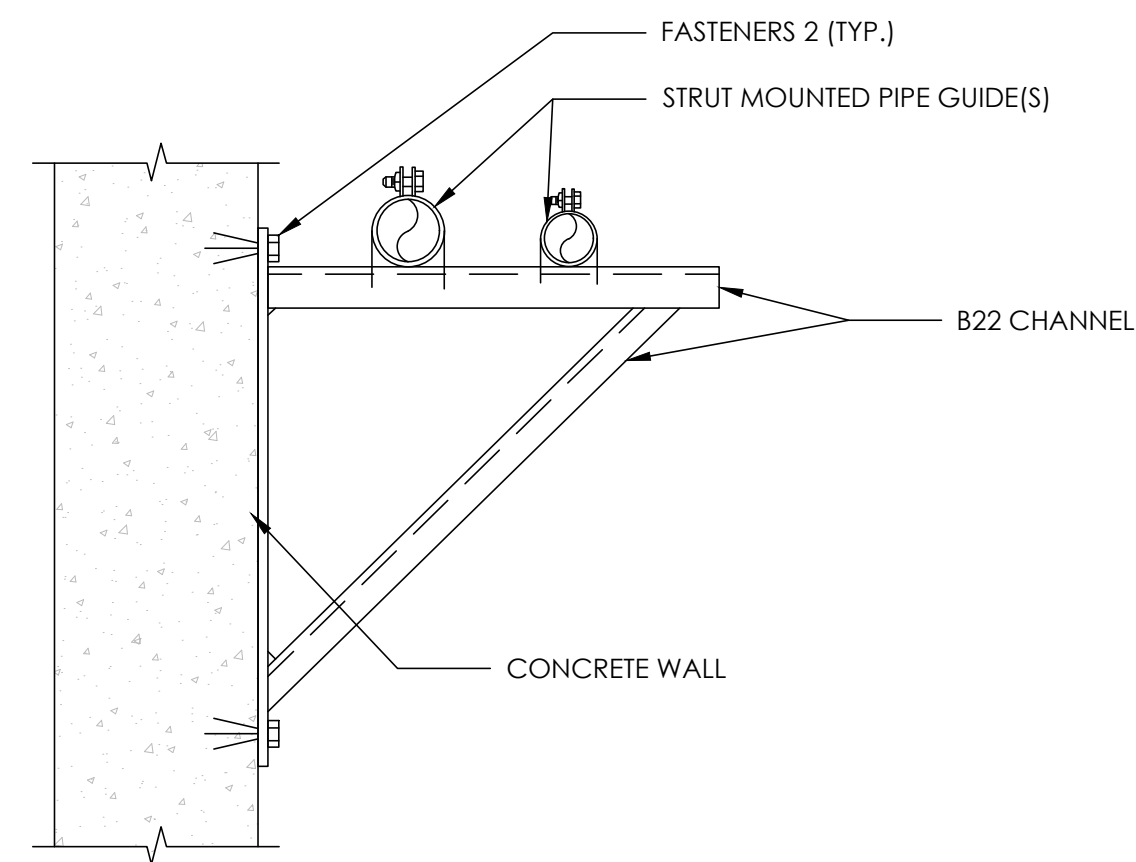

8 WALL MOUNTED PIPE SUPPORT
C-203 NOT TO SCALE

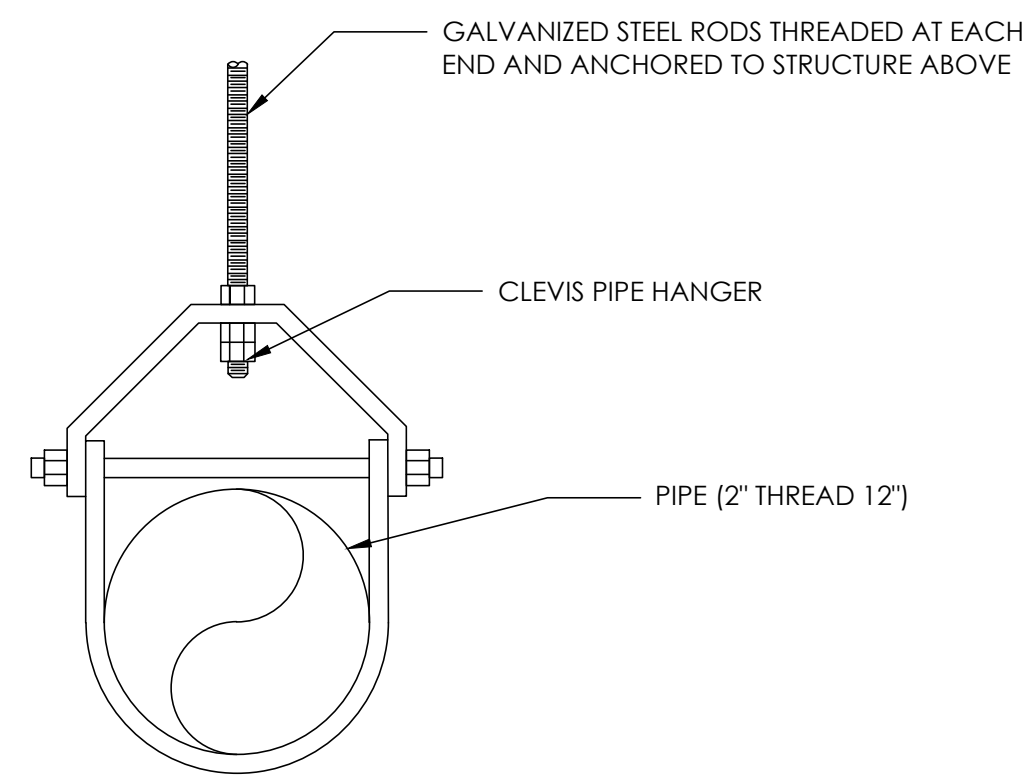

9 CLEVIS HANGER
C-203 NOT TO SCALE

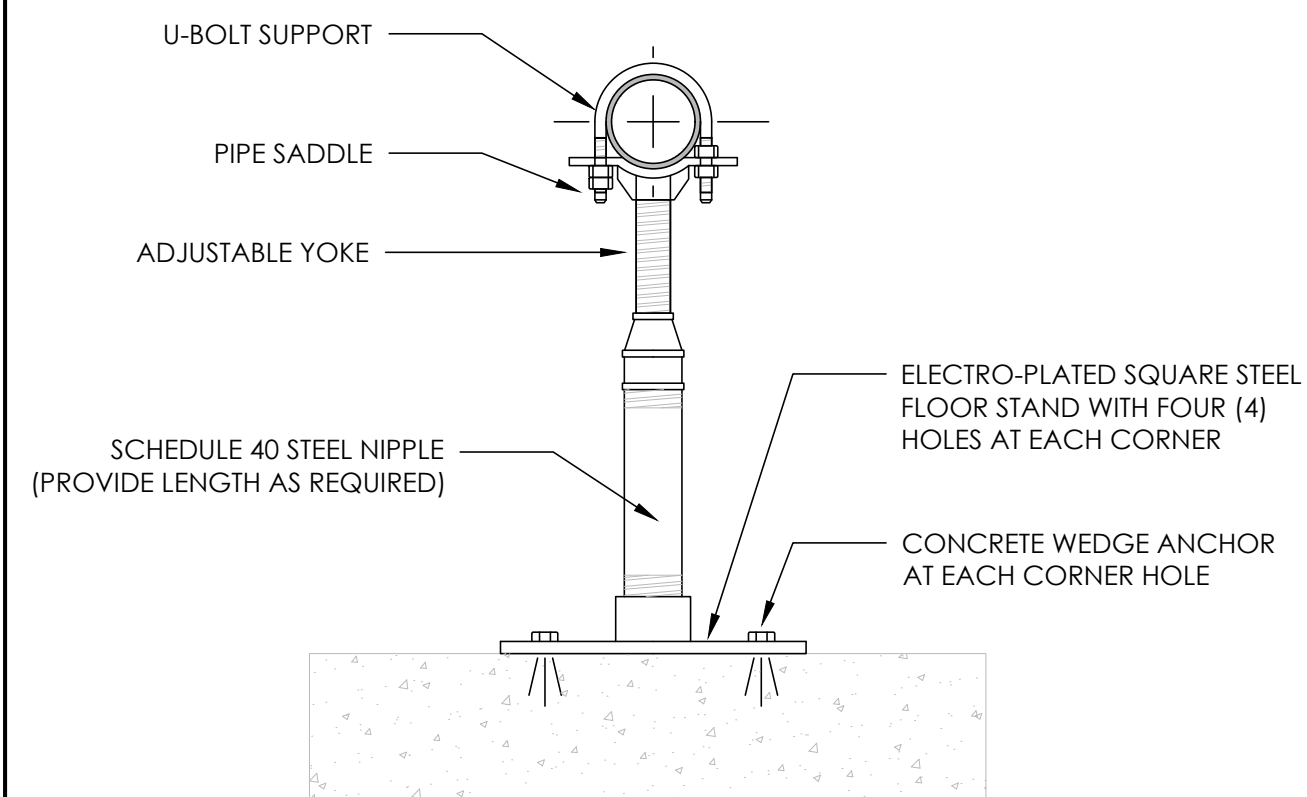

10 FLOOR MOUNTED PIPE SUPPORT
C-203 NOT TO SCALE

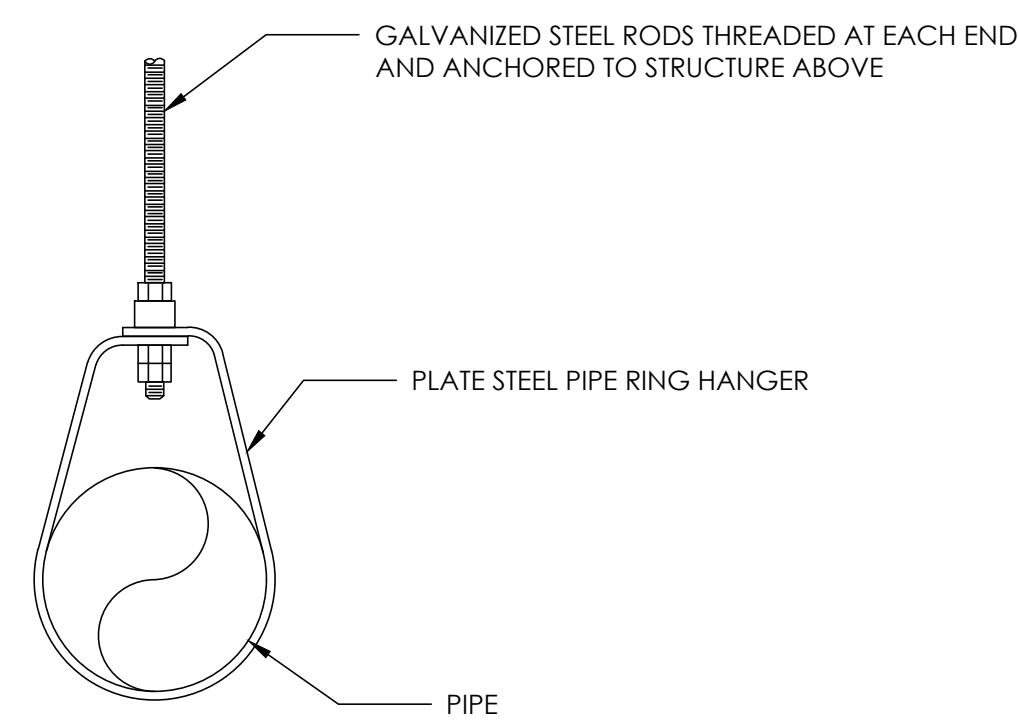

11 SWIVEL PIPE SUPPORT
C-203 NOT TO SCALE

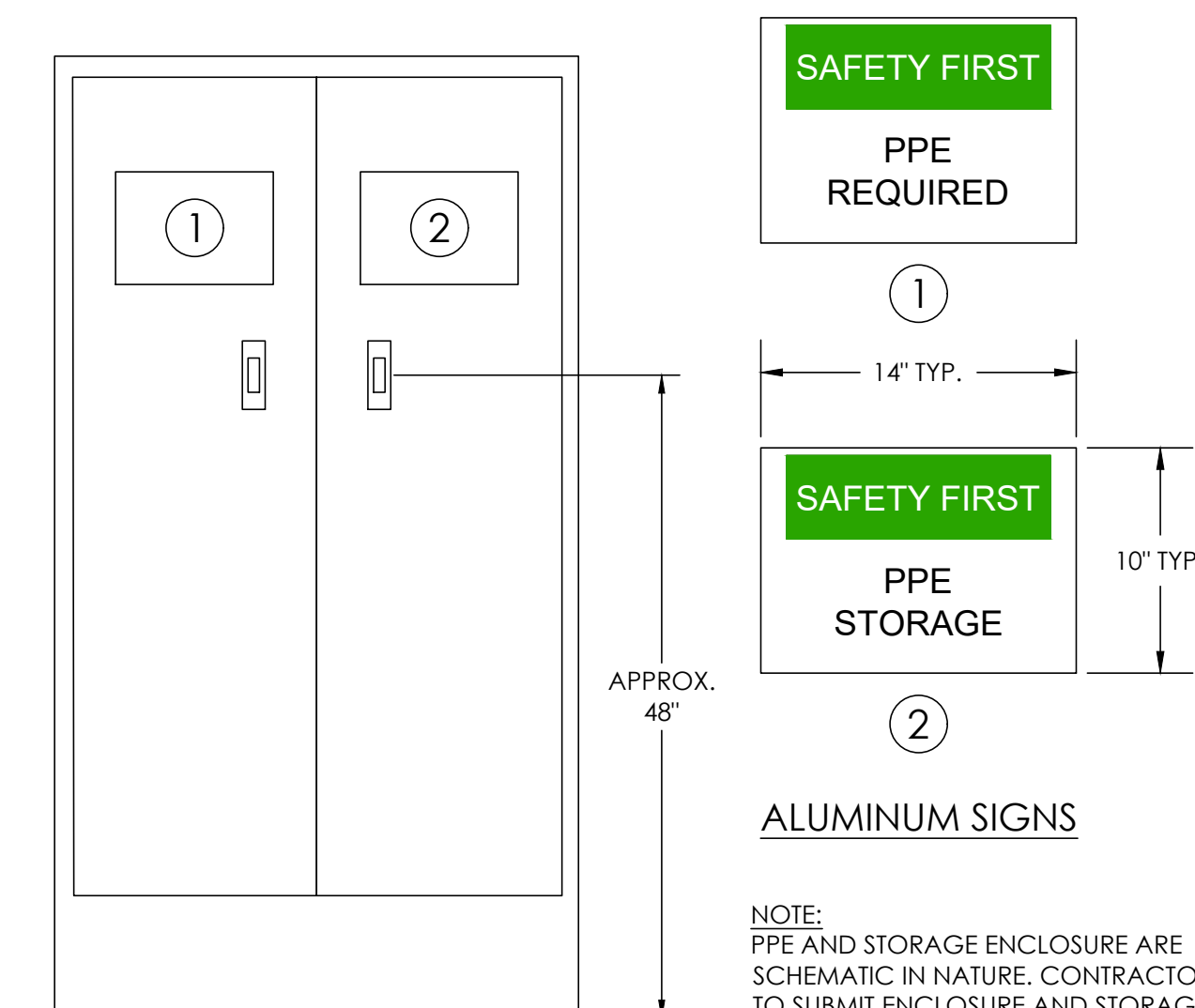

12 PPE AND STORAGE ENCLOSURE
C-203 NOT TO SCALE

SAFETY FIRST
PPE
REQUIRED

SAFETY FIRST
PPE
STORAGE

ALUMINUM SIGNS

NOTE:
PPE AND STORAGE ENCLOSURE ARE
SCHEMATIC IN NATURE. CONTRACTOR
TO SUBMIT ENCLOSURE AND STORAGE
ITEMS FOR REVIEW AND APPROVAL.



Michael Igo
6/19/23

PERMITTING SET - NOT FOR CONSTRUCTION



CITY OF NEWBURYPORT
60 PLEASANT STREET
NEWBURYPORT, MA 01950

Rev No	Date	Drawn	Chkd	Description
REV 1	6/19/23	AEH	MI	DRAWING SET FOR NOTICE OF INTENT
REV 0	4/14/23	AEH	MI	DRAWING SET FOR NOTICE OF INTENT
Rev No	Date	Drawn	Chkd	Description
				Revisions

Designed By:
A. Hammond

Checked By:
M. Igo

Date:
4-14-2023

SCALE: AS SHOWN

BARTLET MALL RESTORATION PROJECT

CIVIL DETAILS - 3

Sheet No.

C-203

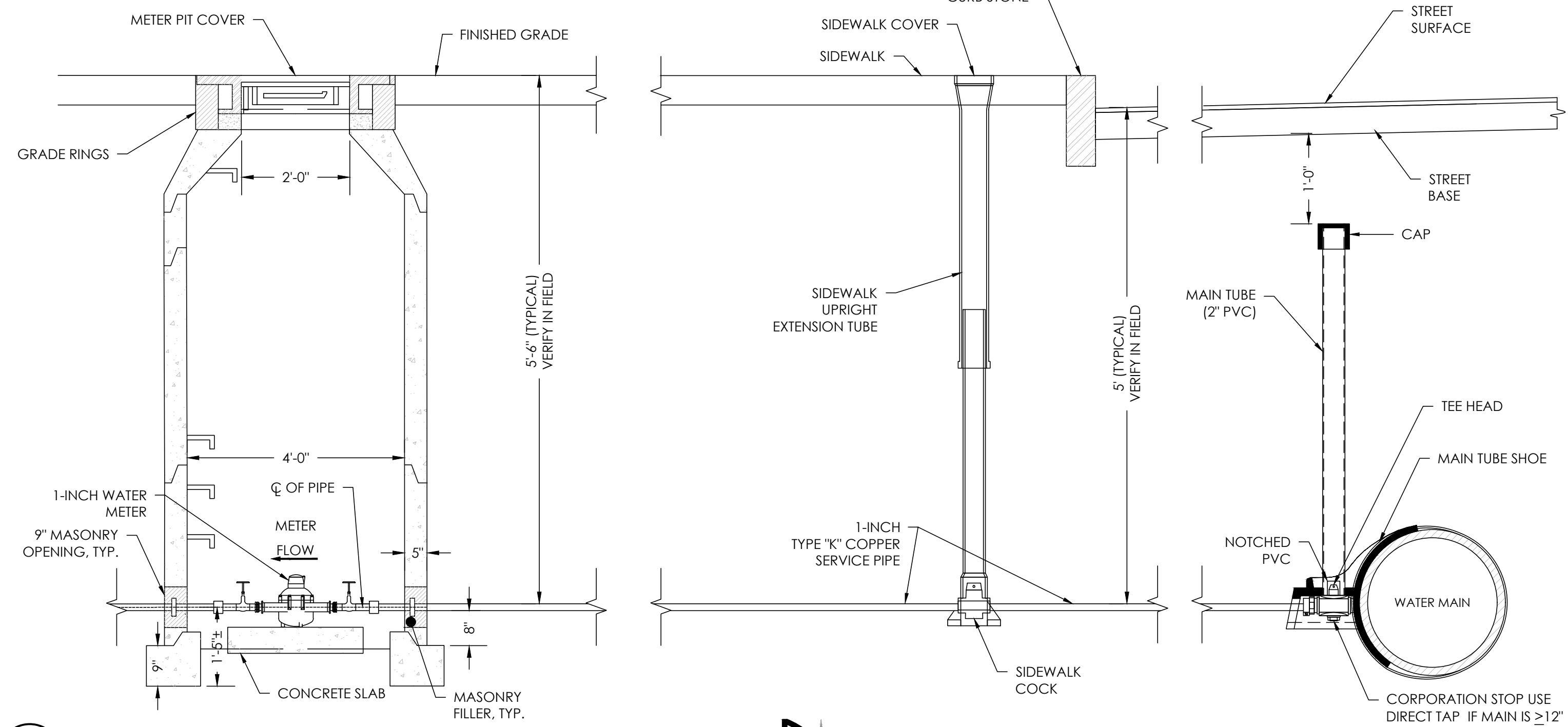

14 DOMESTIC WATER CONNECTION
C-204 NOT TO SCALE

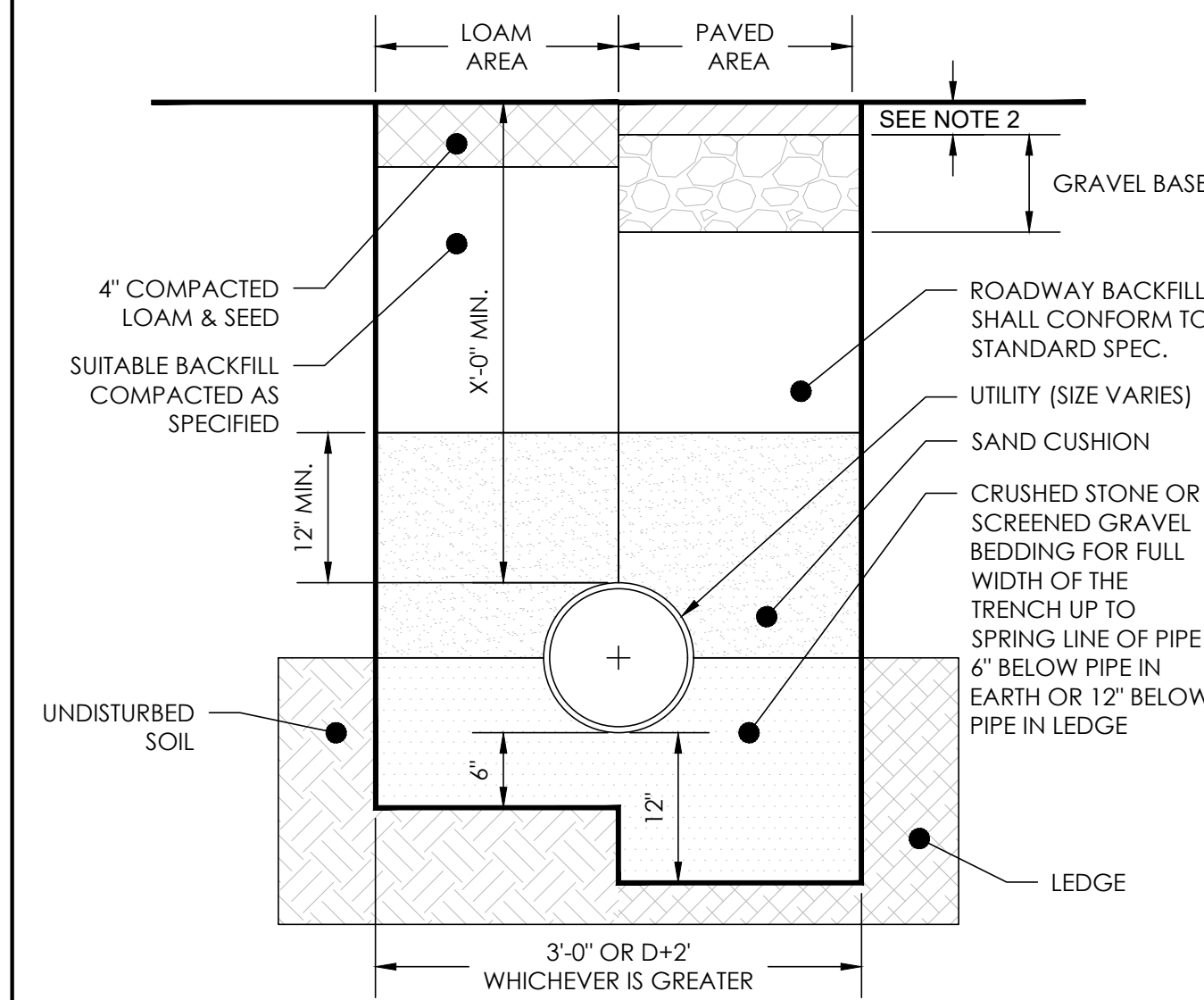

- NOTES:
1. ALL MATERIAL SHALL CONFORM TO CITY/TOWN OF DEPARTMENT OF PUBLIC WORKS.
 2. NEW ROADWAY CONSTRUCTION SHALL CONFORM TO CITY/TOWN SPECIFICATIONS.
 3. IN LIEU OF THE 12\"/>

17 UTILITY TRENCH DETAIL (NOT WITHIN POND LIMITS)
C-204 NOT TO SCALE

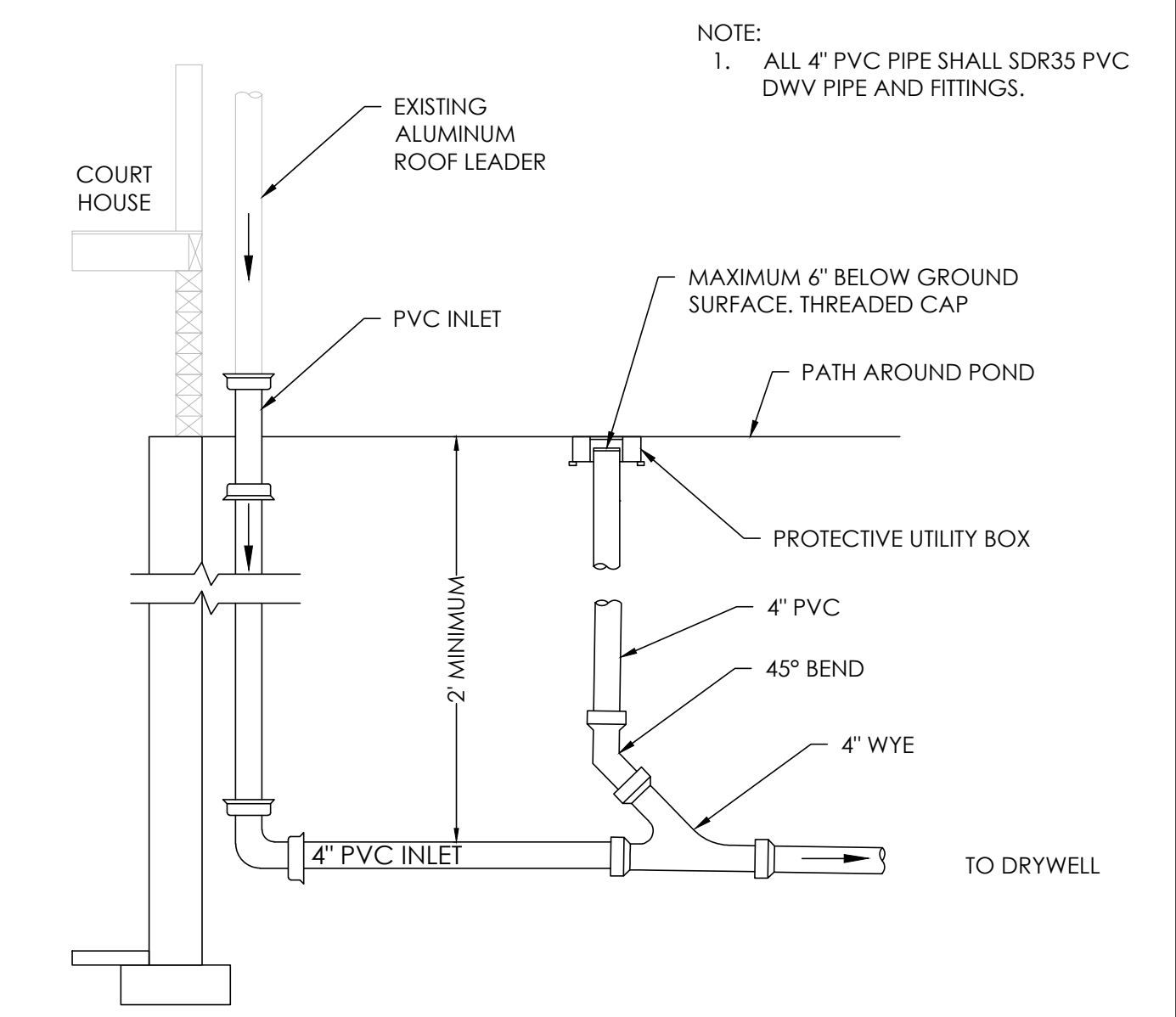

16 ROOF LEADER TO DRYWELL
C-204 NOT TO SCALE

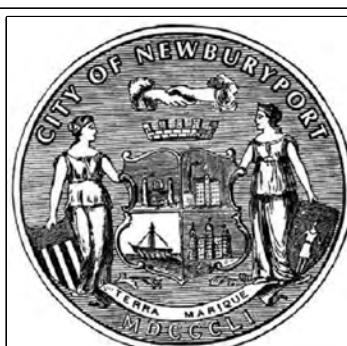

CITY OF NEWBURYPORT
60 PLEASANT STREET
NEWBURYPORT, MA 01950

Rev No	Date	Drawn	Chkd	Description
REV 1	6/19/23	AEH	MI	DRAWING SET FOR NOTICE OF INTENT
REV 0	4/14/23	AEH	MI	DRAWING SET FOR NOTICE OF INTENT
Revisions				

Designed By:
A. Hammond

Checked By:
M. Igo

Date:
4-14-2023

SCALE: AS SHOWN

BARTLET MALL RESTORATION PROJECT

CIVIL DETAILS - 4

Sheet No.
C-204

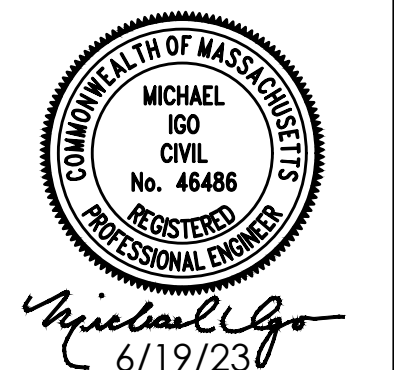

PERMITTING SET - NOT FOR CONSTRUCTION

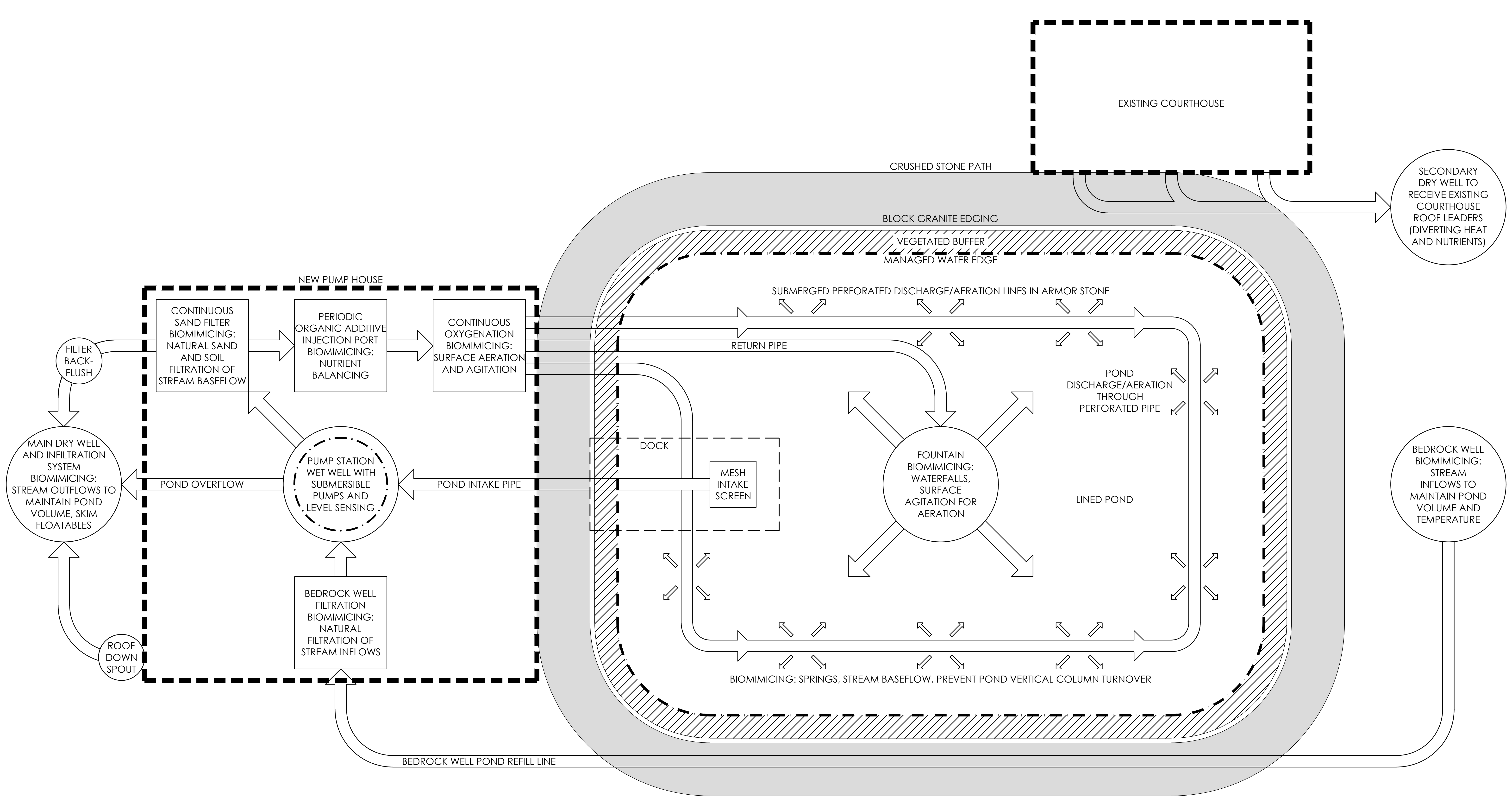
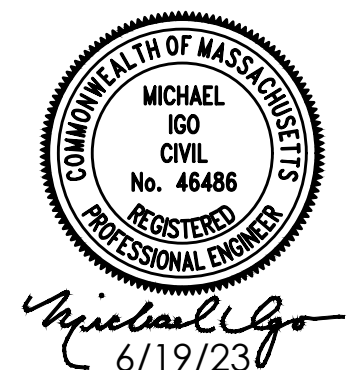
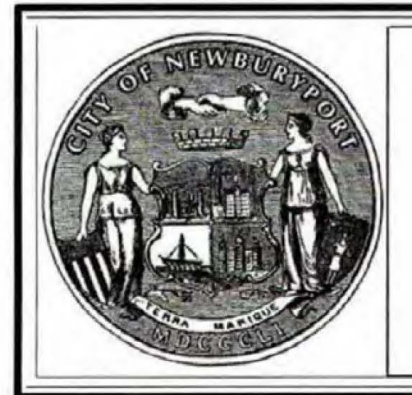

DIAGRAM NOT TO SCALE:
 PROVIDED TO DEMONSTRATE
 WATER FLOW PATHS FOR
 POND WATER QUALITY



PERMITTING SET - NOT FOR CONSTRUCTION

<p>CITY OF NEWBURYPORT 60 PLEASANT STREET NEWBURYPORT, MA 01950</p>	<table border="1"> <tr> <td>REV 1</td> <td>6/19/23</td> <td>AEH</td> <td>MI</td> <td></td> </tr> <tr> <td>REV 0</td> <td>4/14/23</td> <td>AEH</td> <td>MI</td> <td></td> </tr> <tr> <td>Rev No</td> <td>Date</td> <td>Drawn</td> <td>Chkd</td> <td></td> </tr> </table>	REV 1	6/19/23	AEH	MI		REV 0	4/14/23	AEH	MI		Rev No	Date	Drawn	Chkd		<table border="1"> <tr> <td>Designed By:</td> <td>A. Hammond</td> </tr> <tr> <td>Checked By:</td> <td>M. Igo</td> </tr> <tr> <td>Date:</td> <td>4-14-2023</td> </tr> </table>	Designed By:	A. Hammond	Checked By:	M. Igo	Date:	4-14-2023	SCALE: NONE	BARTLET MALL RESTORATION PROJECT WATER QUALITY SYSTEM ONE LINE DIAGRAM	Sheet No. C-301
	REV 1	6/19/23	AEH	MI																						
	REV 0	4/14/23	AEH	MI																						
	Rev No	Date	Drawn	Chkd																						
Designed By:	A. Hammond																									
Checked By:	M. Igo																									
Date:	4-14-2023																									
<table border="1"> <tr> <td></td> <td></td> <td></td> <td></td> <td></td> </tr> <tr> <td></td> <td></td> <td></td> <td></td> <td></td> </tr> <tr> <td></td> <td></td> <td></td> <td></td> <td></td> </tr> </table>																DRAWING SET FOR NOTICE OF INTENT										



CITY OF NEWBURYPORT
60 PLEASANT STREET
NEWBURYPORT, MA 01950

Rev No	Date	Drawn	Chkd	Description
4	6/26/23	KT		ADA study & granite realignment & rotate pump house
3	5/22/23	KT		Relocated utility/storage shed & dock
2	1/18/23	KT		Revised ellipse
1	2/6/22	KT		Revised granite edge
Revisions				

Designed By:
Kim Turner
Checked By:
[NAME]
Date:
12-01-2022

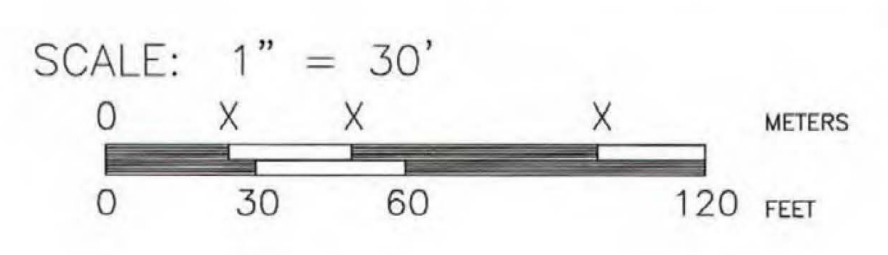

BARTLET MALL RESTORATION PROJECT
CONCEPTUAL SITE PLAN

Sheet No.
L-1

Committee Items – May 13, 2024

Licenses & Permits

In Committee:

- APPL00199_04_29_2024 10th Annual Harborside Half Marathon & 5K Sunday, Nov. 10th 9am-1:30pm
- APPL00200_04_29_2024 Tri-State Trek Sat. 6/22 10:30am-2:30pm
- APPL00201_04_29_2024 NPS- Kona Ice Truck Waterfront Performing Arts Festival 5/18 1-4pm

NEWBURYPORT SPECIAL EVENT APPLICATION

Tel.

Fax.

(For Street Closure or Any Use of a Public Way - Please complete page 3 of this application)**NAME OF EVENT:** 10th Annual Harborside Half Marathon & 5KDate: Sunday, November 10th, 2024 Time: from 9:00 AM to 1:30 PMRain Date: N/A Time: from N/A to N/A2. Location*: Start Line: Industrial Park (40 Parker Street) Finish Line: Cashman Park

*Please Note: If the location is a public park or the rail trail, please also contact the Parks Department

3. Description of Property: As per locations above Public Private 4. Name of Organizer: Ventures Endurance City Sponsored Event: Yes No Contact Person Erik BoucherAddress: 51 Dynamic Drive, Unit #3, Scarborough, ME 04074 Telephone: 207-210-8655E-Mail: eboucher@venturesendurance.com Cell Phone: 207-210-8655Day of Event Contact & Phone: Erik Boucher - 207-210-86555. Number of Attendees Expected: 2,0006. MA Tax Number: N/A7. Is the Event Being Advertised? Yes Where? Online social media (facebook, instgram, etc.)8. What Age Group is the Event Targeted to? 15-759. Have You Notified Neighborhood Groups or Abutters? Yes No Who? Notice signs will be posted on the route and all establishments on course will be sent a notice mailer prior to event day.**ACTIVITIES:** (Please check where applicable.) Subject to Licenses & Permits from Relevant City DepartmentsA. Vending*: Food Beverages Alcohol Goods Total # of Vendors TBD

*If checked, signature from Health Director required (Page 3)

B. Entertainment: (Subject to City's Noise Ordinance.) Live Music DJ Radio/CD Performers Dancing Amplified Sound ^{On-Site} Announcer Stage C. Games /Rides: Adult Rides Kiddie Rides Games Raffle Other Total # Name of Carnival Operator: Address: Telephone:

D. Organizer is responsible for clean-up during and after event. All trash must be collected and removed from event location immediately at the end of the event unless prior written agreement had been made with the Department of Public Services (DPS).

Will you be conducting the clean-up for this event? Yes No

If yes:

a) How many trash receptacles will you be providing? 15 managed by our staff and volunteers

b) How many recycling receptacles will you be providing? 6 managed by our staff and volunteers

c) Will you be contracting for disposal of : **Trash** Yes No **Recycling** Yes No

i. If yes, size of dumpster(s) : **Trash** 20 yard **Recycling** _____

ii. Name of disposal company: **Trash** Meadows Disposal Co **Recycling** Meadows Disposal Co

iii. If no, will you remove trash & recycling with organizers' cars or trucks? Yes N/A No N/A

iv. If no, where will the trash & recycling be disposed ? N/A

If no:

a) # of trash container(s) to be provided by DPS _____

b) # of recycling container(s) to be provided by Recycling Office _____

c) \$45.00/hr/DPS employee charge must be paid by the organizer to DPS in advance of the event (Fee for Special Events). The hours required for the event will be determined by DPS.

All fees must be paid prior to the event. Check or money order is payable to the City

of Newburyport. E. Portable Toilets: (Each cluster of portable toilets must include at least

one ADA accessible toilet)

35 Standard

3 ADA accessible

Name of company providing the portable toilets: United Site Services

FOR STREET CLOSURE OR ANY USE OF A PUBLIC WAY

PARADE _____

ROAD RACE _____

WALKATHON _____

1. Name of the Group or Person Sponsoring the Road Race, Parade, Walkathon:

Ventures Endurance

2. Name, Address & Daytime Phone Number of Organizer: _____

Erik Boucher

51 Dynamic Drive, Unit #3, Scarborough, ME 04074

Phone: 207-210-8655

3. Name, Address & 24/7 Telephone Number of Person Responsible for Clean Up _____

Erik Boucher - 207-210-8655

51 Dynamic Drive, Unit #3, Scarborough, ME 04074

4. Date of Event: Sunday, November 10th, 2024 Expected Number of Participants: 2,000

5. Start Time: 9:00 AM Half Marathon, 9:15 5K Expected End Time: 1:30 PM

6. Road Race, Parade or Walkathon Route: (List street names & **attach map of route**): 2 Distances - Half Marathon & 5K

Roads utilized are Parker Street, Muliken Way, Malcolm Hoyt Drive, Scotland Road, Indian Hill St Middle Street, Chase Street, Rogers Street, Turkey Hill Road, Opportunity Way, and Perkins Way. Clipper City Rail Trail will also be used.

7. Locations of Water Stops (if any): Mile 2.1, Mile 4.4, Mile 6.2, Mile 8.7, and Mile 11.8

8. Will Detours for Motor Vehicles Be Required? Y If so, where? Parker St & Muliken Way

9. Formation Location & Time for Participants: 7:45 AM - 9:00 AM at 40 Parker Street (Start Area)

10. Dismissal Location & Time for Participants: 9:30 AM - 1:00 PM at Cashman Park (Finish Area)

11. Additional Parade Information:

• Number of Floats: _____

• Locations of Viewing Stations: _____

• Are Weapons Being Carried: Yes _____ No _____

• Are Marshalls Being Assigned to Keep Parade Moving: Yes _____ No _____

APPROVAL SIGNATURES REQUIRED FOR STREET CLOSURE OR ANY USE OF A PUBLIC WAY

CITY MARSHAL [Signature] 4 Green St. FIRE CHIEF Barry Salt 0 Greenleaf St.

DEPUTY DIRECTOR [Signature] 100 P. Perry Way CITY CLERK _____ 60 Pleasant St.

HEALTH DIRECTOR [Signature] 60 Pleasant St. (only needed when Food & Beverage Vendors are included in the event)

DEPARTMENT APPROVAL (for Committee Member use only):

It will be necessary for you to obtain permits or certificates from the following Departments: Please note that costs for some City support services during an event are an estimate only. Some Departments may forward an invoice for services rendered at the completion of the event, and others may require advance payment.

Date: _____ Signature _____

Required

____ 1. Special Events: _____

____ 2. Police: _____
 Is Police Detail Required: _____ # of Details Assigned: _____

____ 3. Traffic, Parking & Transportation: _____

____ 4. ISD/Health: _____

____ 5. Recycling: _____

____ 6. ISD/Building: _____

____ 7. Electrical: _____

____ 8. Fire: _____
 Is Fire Detail Required: _____ # of Details Assigned: _____

____ 9. Public Works: *Fee for Special Events: \$45/hr/DPS employee for trash handling/staging etc. may apply*
 Yes: \$_____ due on _____ No Fee for Special Events applies
 Other requirements/instructions per DPS _____

____ 10. Parks Department: _____

____ 11. License Commission _____

The departments listed above have their own application process. Applicants are responsible for applying for and obtaining all required permits & certificates from the various individual departments

Sec. 13-97. - Road races, walkathons, bicycle and other multidisciplined events.

(a) *Short title.* This section may be cited as the "road races, walkathons and bicycle events."

(b) *Purpose and intent.* The use of city streets and sidewalks for the purpose of road races, walkathons or bicycle tours are positive events that promote exercise, general good health and Newburyport as a destination. These events do from time to time create hardships, impacting neighborhoods and traffic. To create a balance between conflicting interests, by safeguarding participants, residents, visitors and the City of Newburyport, this section will define and codify the procedure for the benefit of all.

(c) *Definitions.*

(1) *Road race.* A competitive or non-competitive running event that utilizes the streets, sidewalks and/or crosses over streets or sidewalks within city limits and in which an entry fee is required or charitable donation is solicited or suggested.

(2) *Walkathon.* A competitive or non-competitive walk event that utilizes the streets, sidewalks and/or crosses over streets or sidewalks within city limits and in which an entry fee is required or charitable donation is solicited or suggested.

(3) *Bicycle race.* A competitive or non-competitive bicycling event that utilizes the streets, sidewalks and/or crosses over streets or sidewalks within city limits and in which an entry fee is required or charitable donation is solicited or suggested.

(4) *Multidisciplined event.* A competitive or non-competitive event requiring or offering running, walking, biking, swimming or any combination thereof in which an entry fee is required or a charitable donation is solicited or suggested.

(5) *Event.* Any road race, walkathon, bicycle race, multi-disciplined event as defined above.

(d) *Limitations.*

(1) *Procedure.* All events shall, through that event's organizer, board of directors, charity foundation or designee ("organizer") apply for city council authorization to hold the event through the office of the city clerk no later than sixty (60) days before the event's proposed date. There shall be a grace period through December 31, 2017, during which applications will be accepted beyond the prescribed due date. Prior to application with the city council, the event shall file and receive approval from all applicable city departments, boards, and commissions. Copies of such approved applications, including along with documentation of any fees, donations, in-kind donations paid as part of said application(s), shall be included as part of the city council application.

The date of application is the date a completed application is submitted to the city clerk's office and stamped by the same. The city clerk, upon review of the completed form, will place the application on the next regular city council agenda, even if such submission is a late file. Upon following the procedures of the council, as deemed appropriated in the sole judgment of the council, the application will be considered approved if the council votes favorably by majority. The application shall name one (1) person responsible on the application and shall provide contact information to include name, address, email address, and telephone number.

(2) *Exemptions.* Each event organizer or organization shall comply with this ordinance and no exemptions will be permitted.

(3) *Course map.* All applications shall be accompanied by a legible, precise course map showing the event route, water stops, refreshment stops, and so-called "port-a-potties". The course map shall also include any road closures, detours and parking areas. The course map shall be approved by police, fire, department of public services, parks commission and harbormasters departments prior to submission to the city clerk.

(4) *Electronic amplifier.* Electronic amplifiers, loudspeakers and bullhorn use shall be requested at time of application. Under no circumstances will they be used for public address announcements or music before 8:00 a.m., except for Sundays when electronic amplifiers, loud speakers or bullhorns will not be used for public address announcements or music before 9:00 a.m.

(5) *Road closure.* No ways, public or private, boat ramps or parking lots controlled or patrolled by the city shall be closed without authorization. Authorization shall be considered granted only if said closure(s) are contained in the approved permit. It is the sole responsibility of the race organizers to notify residents fourteen (14) days in advance that neighborhood roads will be closed if no alternate route is available to those residents. Notification shall be made by race organizers by informational packet drop-off at all residences that may be impacted, including, but not limited to, road closures, restricted driveway access, parking restrictions, or noise. In the case of multi-family residences with so-called security doors, notification will be sufficient at said security door. A copy of the notification shall be provided to the city clerk and, when possible, posted on the city website and distributed via email. Further,

a list of all streets notified shall be provided to the city clerk to be date stamped and appended to the application record. Press releases and other media type notifications are encouraged.

(6) *Insurance.* All events shall have an insurance policy or rider in effect for the event naming the "City of Newburyport" as an additional insured. The policy shall be no less than two million dollars (\$2,000,000.00).

(7) *Event termination.* If in the judgment of the city marshal, fire chief or department of public services (DPS) director or designees thereof determine that an event is unsafe due to existing conditions, that event may be stopped, terminated or suspended. In the case of a multidiscipline event such as a triathlon, the harbormaster or his/her designee may likewise stop, terminate or suspend the swimming portion for cause.

(8) *Event and traffic security.* The city marshal, fire chief, DPS director or in the case of a triathlon, the harbormaster can require special duty personnel to assist in the organizing and coordinating the safety and security of the event. All special duty assignments will be paid by the event organizers.

(9) *Clean-up.* The event organizers shall be responsible for post event trash collection, removal of signage, directional arrows, advertisements or other promotional material associated with the event.

10) *Parking.* The event organizers shall be responsible for including parking instructions in materials disseminated to event participants. If the event is happening within one-half mile of municipal parking, then participants shall be asked to park at such parking facilities.

(11) *Notification of previous event organizers.* To the extent reasonably possible, the city clerk shall notify all event organizers from events held from 2014—2016, inclusive, by a one-time phone, email, or letter of the new application timeline and other requirements.

(12) *Simplification.* Departments are encouraged to unify their respective applications into a singular application, managed and distributed by the city clerk's office.

(13) *Americans with Disabilities Act.* Event organizers are reminded of the importance of and expectation of adherence to the Americans with Disabilities Act of 1990 (42 U.S.C § 12101) and subsequent applicable amendments.

(e) *Enforcement.*

(1) *Regulations.* Consistent with this section, the city shall promulgate regulations to enforce and otherwise implement the provisions of this section upon passage by the city council. Any event previously approved by city council shall be deemed permitted.

(2) *Warning.* In the circumstance that this section is violated, the enforcement may consist of a warning. Any warnings issued for violation(s) will be reported to the city clerk and city council and may be used as a factor in future application approvals and denials.

(3) *Noncriminal disposition.* If the city determines that a violation has occurred in which a noncriminal violation is issued, the named event organizer shall be penalized by a non-criminal disposition as provided in Massachusetts General Law as adopted by the City of Newburyport as a general ordinance in section 1-17 of chapter 1 of the Code or Ordinances of the City of Newburyport in the amounts set herein in subsection (e)(4) below.

(4) *Violation.* The non-criminal violation shall be one hundred dollars (\$100.00) for the first offense and two hundred fifty dollars (\$250.00) for second and subsequent offenses. Any non-criminal citations issued for violation(s) will be reported to the city clerk and city council and shall be used as a factor in future application approvals and denials.

(5) *Failure to notify.* If the event fails to notify residents and provide documentation to the city clerk, pursuant to subsection (d)(5) above, shall render that organization ineligible to receive an event permit for a period of twelve (12) months unless special leave is granted by two-thirds supervote of the city council.

I fully understand and agree to all the terms set forth in this application. The information that I have provided is truthful and accurate. I accept all responsibility related to this event.

Signed: 

Date: 4/2/2024



1 Distance

--- Course

S Start

F Finish

💧 Water

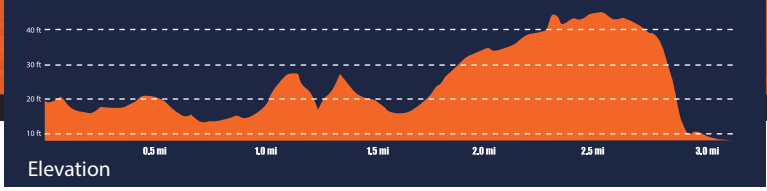

2024 5K





- 1** Distance
- Course
- S** Start
- F** Finish
- Water

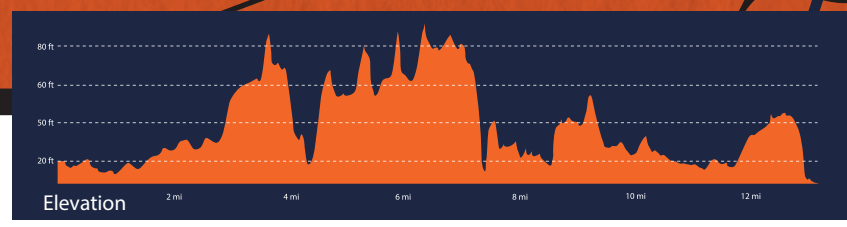

2024 Half Marathon





VOLUNTEER & PARTICIPANT PARKING

PORTABLE TOILETS

MEDICAL

FINISH

REGISTRATION

5K & HALF MARATHON FINISH

GEAR CHECK

**POST-RACE BEER GARDEN & FOOD
40' X 80' TENT**

STAFF PARKING

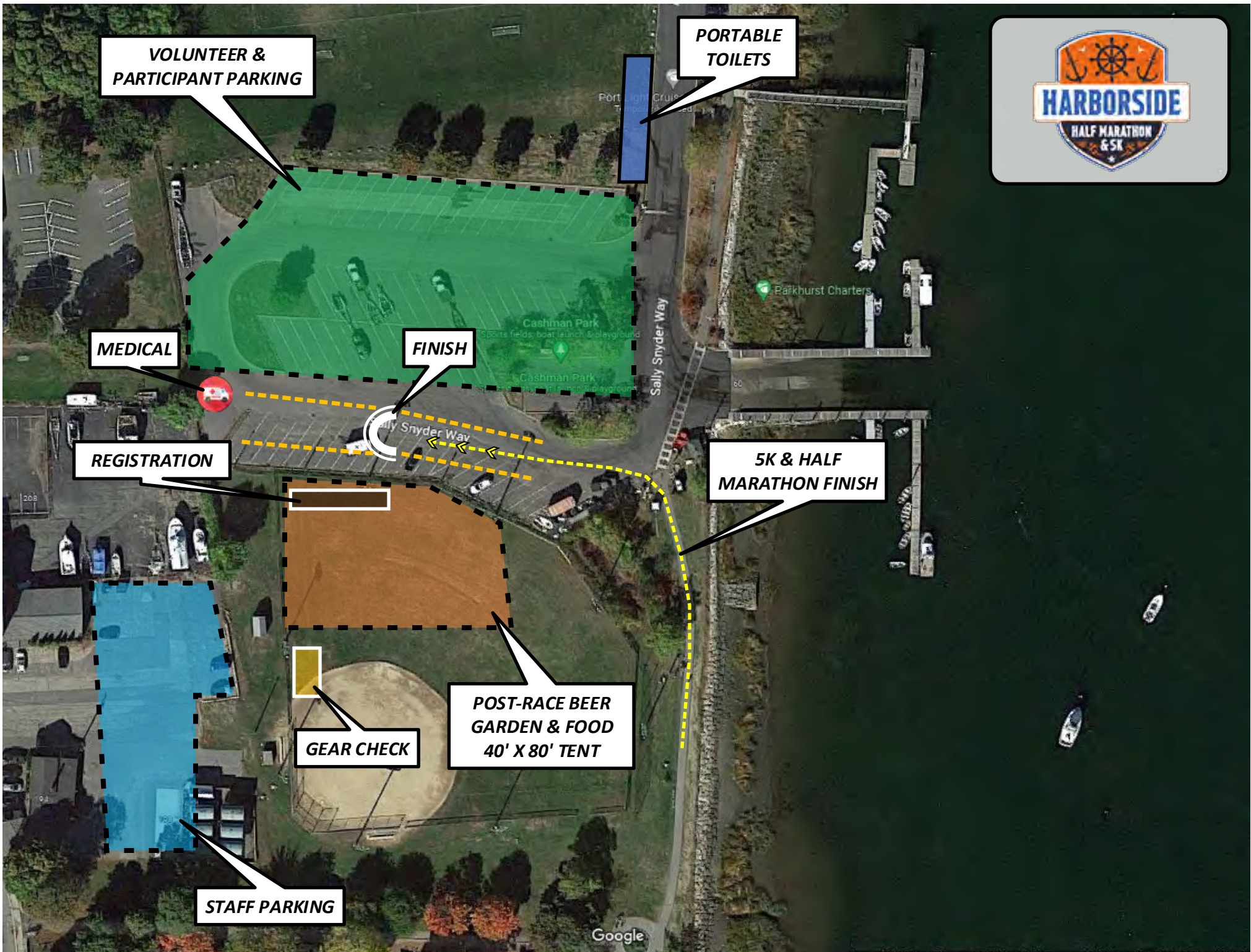



CERTIFICATE OF LIABILITY INSURANCE

DATE(MM/DD/YYYY)
03/01/2024

THIS CERTIFICATE IS ISSUED AS A MATTER OF INFORMATION ONLY AND CONFERS NO RIGHTS UPON THE CERTIFICATE HOLDER. THIS CERTIFICATE DOES NOT AFFIRMATIVELY OR NEGATIVELY AMEND, EXTEND OR ALTER THE COVERAGE AFFORDED BY THE POLICIES BELOW. THIS CERTIFICATE OF INSURANCE DOES NOT CONSTITUTE A CONTRACT BETWEEN THE ISSUING INSURER(S), AUTHORIZED REPRESENTATIVE OR PRODUCER, AND THE CERTIFICATE HOLDER.

IMPORTANT: If the certificate holder is an ADDITIONAL INSURED, the policy(ies) must have ADDITIONAL INSURED provisions or be endorsed. If SUBROGATION IS WAIVED, subject to the terms and conditions of the policy, certain policies may require an endorsement. A statement on this certificate does not confer rights to the certificate holder in lieu of such endorsement(s).

PRODUCER Aon Risk Services Northeast, Inc. New York NY Office One Liberty Plaza 165 Broadway, Suite 3201 New York NY 10006 USA	CONTACT NAME: PHONE (A/C. No. Ext): (866) 283-7122 FAX (A/C. No.): (800) 363-0105		
	E-MAIL ADDRESS:		
INSURED Ventures Endurance Events, LLC 6129 Airways Blvd, STE 1 Chattanooga TN 37421 USA	INSURER(S) AFFORDING COVERAGE		NAIC #
	INSURER A: Everest National Insurance Co		10120
	INSURER B:		
	INSURER C:		
	INSURER D:		
	INSURER E:		

Holder Identifier :

COVERAGES **CERTIFICATE NUMBER:** 570104157881 **REVISION NUMBER:**

THIS IS TO CERTIFY THAT THE POLICIES OF INSURANCE LISTED BELOW HAVE BEEN ISSUED TO THE INSURED NAMED ABOVE FOR THE POLICY PERIOD INDICATED. NOTWITHSTANDING ANY REQUIREMENT, TERM OR CONDITION OF ANY CONTRACT OR OTHER DOCUMENT WITH RESPECT TO WHICH THIS CERTIFICATE MAY BE ISSUED OR MAY PERTAIN, THE INSURANCE AFFORDED BY THE POLICIES DESCRIBED HEREIN IS SUBJECT TO ALL THE TERMS, EXCLUSIONS AND CONDITIONS OF SUCH POLICIES. LIMITS SHOWN MAY HAVE BEEN REDUCED BY PAID CLAIMS. **Limits shown are as requested**

INSR LTR	TYPE OF INSURANCE	ADDITIONAL INSURED	SUBROGATION WAIVED	POLICY NUMBER	POLICY EFF (MM/DD/YYYY)	POLICY EXP (MM/DD/YYYY)	LIMITS
A	<input checked="" type="checkbox"/> COMMERCIAL GENERAL LIABILITY <input type="checkbox"/> CLAIMS-MADE <input checked="" type="checkbox"/> OCCUR <input checked="" type="checkbox"/> Liquor Liability GEN'L AGGREGATE LIMIT APPLIES PER: <input checked="" type="checkbox"/> POLICY <input type="checkbox"/> PROJECT <input type="checkbox"/> LOC OTHER:			SI8GL01746241	02/25/2024	02/25/2025	EACH OCCURRENCE \$1,000,000 DAMAGE TO RENTED PREMISES (Ea occurrence) \$100,000 MED EXP (Any one person) Excluded PERSONAL & ADV INJURY \$1,000,000 GENERAL AGGREGATE \$1,000,000 PRODUCTS - COMP/OP AGG \$1,000,000
	AUTOMOBILE LIABILITY <input type="checkbox"/> ANY AUTO <input type="checkbox"/> OWNED AUTOS ONLY <input type="checkbox"/> SCHEDULED AUTOS <input type="checkbox"/> HIRED AUTOS ONLY <input type="checkbox"/> NON-OWNED AUTOS ONLY						COMBINED SINGLE LIMIT (Ea accident) BODILY INJURY (Per person) BODILY INJURY (Per accident) PROPERTY DAMAGE (Per accident)
A	<input type="checkbox"/> UMBRELLA LIAB <input checked="" type="checkbox"/> OCCUR <input checked="" type="checkbox"/> EXCESS LIAB <input type="checkbox"/> CLAIMS-MADE <input type="checkbox"/> DED <input type="checkbox"/> RETENTION			SI8EX01516241	02/25/2024	02/25/2025	EACH OCCURRENCE \$1,000,000 AGGREGATE \$1,000,000
	WORKERS COMPENSATION AND EMPLOYERS' LIABILITY ANY PROPRIETOR / PARTNER / EXECUTIVE OFFICER/MEMBER EXCLUDED? (Mandatory in NH) If yes, describe under DESCRIPTION OF OPERATIONS below			N/A			<input type="checkbox"/> PER STATUTE <input type="checkbox"/> OTHER E.L. EACH ACCIDENT E.L. DISEASE-EA EMPLOYEE E.L. DISEASE-POLICY LIMIT

Certificate No : 570104157881

DESCRIPTION OF OPERATIONS / LOCATIONS / VEHICLES (ACORD 101, Additional Remarks Schedule, may be attached if more space is required)
RE:Harborside Half Marathon & 5k.
City of Newburyport is included as Additional Insured in accordance with the policy provisions of the General Liability policy.

CERTIFICATE HOLDER**CANCELLATION**

City of Newburyport PO Box 550 Newburyport MA 01950 USA	SHOULD ANY OF THE ABOVE DESCRIBED POLICIES BE CANCELLED BEFORE THE EXPIRATION DATE THEREOF, NOTICE WILL BE DELIVERED IN ACCORDANCE WITH THE POLICY PROVISIONS. AUTHORIZED REPRESENTATIVE
---	--



NEWBURYPORT SPECIAL EVENT APPLICATION

Tel.

Fax.

(For Street Closure or Any Use of a Public Way - Please complete page 3 of this application)

NAME OF EVENT: Tri-State Trek

Date: Saturday, June 22nd 2024 Time: from 10:30 AM to 2:30 PM

Rain Date: N/A Time: from _____ to _____

2. Location*: Riding on the Roads of Newburyport- Attached isa Cue Sheet and Map

*Please Note: If the location is a public park or the rail trail, please also contact the Parks Department

3. Description of Property: Riding on the Roads of Newburyport Public Private _____

4. Name of Organizer: ALS Therapy Development Institute City Sponsored Event: Yes _____ No

Contact Person

Address: 480 Arsenal St STE 201, Watertown, MA 02472 Telephone: 617-441-7286

E-Mail: ksweeney@als.net Cell Phone: 631-379-6927

Day of Event Contact & Phone: Kevin Sweeney- 631-379-6927

5. Number of Attendees Expected: 250

6. MA Tax Number: 04-3462719

7. Is the Event Being Advertised? Yes Where? Facebook, Local Calendars, Social Media

8. What Age Group is the Event Targeted to? 18-80

9. Have You Notified Neighborhood Groups or Abutters? Yes _____ No Who? _____

RECEIVED
POLICE DEPT'S OFFICE
NEWBURYPORT, MA
2024 APR 22 AM 11:22

ACTIVITIES: (Please check where applicable.) Subject to Licenses & Permits from Relevant City Departments

A. Vending*: Food _____ Beverages _____ Alcohol _____ Goods _____ Total # of Vendors _____

*If checked, signature from Health Director required (Page 3)

B. Entertainment: (Subject to City's Noise Ordinance.) Live Music _____ DJ _____ Radio/CD _____

Performers _____ Dancing _____ Amplified Sound _____ Stage _____

C. Games /Rides: Adult Rides _____ Kiddie Rides _____ Games _____ Raffle _____

Other _____ Total # _____

Name of Carnival Operator: _____

Address: _____

Telephone: _____

D. Organizer is responsible for clean-up during and after event. All trash must be collected and removed from event location immediately at the end of the event unless prior written agreement had been made with the Department of Public Services (DPS).

Will you be conducting the clean-up for this event? Yes _____ No _____

FOR STREET CLOSURE OR ANY USE OF A PUBLIC WAY

PARADE _____

ROAD RACE X _____

WALKATHON _____

1. Name of the Group or Person Sponsoring the Road Race, Parade, Walkathon:
ALS Therapy Development Institute

2. Name, Address & Daytime Phone Number of Organizer: ALS Therapy Development Institute , 480 Arsenal St
STE201, Watertown, MA 02472 - 617-441-7205

3. Name, Address & 24/7 Telephone Number of Person Responsible for Clean Up _____
ALS Therapy Development Institute , 480 Arsenal St
STE201, Watertown, MA 02472 - 617-441-7205

4. Date of Event: Saturday, June 22nd 2024 Expected Number of Participants: 250

5. Start Time: 9:30 AM Expected End Time: 1:30 PM

6. Road Race, Parade or Walkathon Route: (List street names & **attach map of route**): Attached is Cue Sheet and Map
Riders will come through intermittently during the times listed above.

7. Locations of Water Stops (if any): N/A

8. Will Detours for Motor Vehicles Be Required? No If so, where? _____

9. Formation Location & Time for Participants: N/A

10. Dismissal Location & Time for Participants: N/A

11. Additional Parade Information:

- Number of Floats: _____
- Locations of Viewing Stations: _____
- Are Weapons Being Carried: Yes _____ No _____
- Are Marshalls Being Assigned to Keep Parade Moving: Yes _____ No _____

APPROVAL SIGNATURES REQUIRED FOR STREET CLOSURE OR ANY USE OF A PUBLIC WAY

CITY MARSHAL [Signature] 4 Green St. FIRE CHIEF [Signature] 0 Greenleaf St.
DEPUTY DIRECTOR [Signature] 16A Perry Way CITY CLERK [Signature] 60 Pleasant St.
HEALTH DIRECTOR _____ 60 Pleasant St. (only needed when Food & Beverage Vendors are included in the event)

DEPARTMENT APPROVAL (for Committee Member use only):

It will be necessary for you to obtain permits or certificates from the following Departments: Please note that costs for some City support services during an event are an estimate only. Some Departments may forward an invoice for services rendered at the completion of the event, and others may require advance payment.

<i>Approval Required</i>	Date: _____	Signature _____
___	1. Special Events:	_____
___	2. Police:	_____
	Is Police Detail Required: _____	# of Details Assigned: _____
___	3. Traffic, Parking & Transportation:	_____
___	4. ISD/Health:	_____
___	5. Recycling:	_____
___	6. ISD/Building:	_____
___	7. Electrical:	_____
___	8. Fire:	_____
	Is Fire Detail Required: _____	# of Details Assigned: _____
___	9. Public Works: <i>Fee for Special Events: \$45/hr/DPS employee for trash handling/staging etc. may apply</i>	
	Yes: \$_____ due on _____	No Fee for Special Events applies
	Other requirements/instructions per DPS _____	_____
___	10. Parks Department:	_____
___	11. License Commission	_____

The departments listed above have their own application process.
Applicants are responsible for applying for and obtaining all required
permits & certificates from the various individual departments

Sec. 13-97. - Road races, walkathons, bicycle and other multidisciplined events.

(a) *Short title.* This section may be cited as the "road races, walkathons and bicycle events."

(b) *Purpose and intent.* The use of city streets and sidewalks for the purpose of road races, walkathons or bicycle tours are positive events that promote exercise, general good health and Newburyport as a destination. These events do from time to time create hardships, impacting neighborhoods and traffic. To create a balance between conflicting interests, by safeguarding participants, residents, visitors and the City of Newburyport, this section will define and codify the procedure for the benefit of all.

(c) *Definitions.*

(1) *Road race.* A competitive or non-competitive running event that utilizes the streets, sidewalks and/or crosses over streets or sidewalks within city limits and in which an entry fee is required or charitable donation is solicited or suggested.

(2) *Walkathon.* A competitive or non-competitive walk event that utilizes the streets, sidewalks and/or crosses over streets or sidewalks within city limits and in which an entry fee is required or charitable donation is solicited or suggested.

(3) *Bicycle race.* A competitive or non-competitive bicycling event that utilizes the streets, sidewalks and/or crosses over streets or sidewalks within city limits and in which an entry fee is required or charitable donation is solicited or suggested.

(4) *Multidisciplined event.* A competitive or non-competitive event requiring or offering running, walking, biking, swimming or any combination thereof in which an entry fee is required or a charitable donation is solicited or suggested.

(5) *Event.* Any road race, walkathon, bicycle race, multi-disciplined event as defined above.

(d) *Limitations.*

(1) *Procedure.* All events shall, through that event's organizer, board of directors, charity foundation or designee ("organizer") apply for city council authorization to hold the event through the office of the city clerk no later than sixty (60) days before the event's proposed date. There shall be a grace period through December 31, 2017, during which applications will be accepted beyond the prescribed due date. Prior to application with the city council, the event shall file and receive approval from all applicable city departments, boards, and commissions. Copies of such approved applications, including along with documentation of any fees, donations, in-kind donations paid as part of said application(s), shall be included as part of the city council application.

The date of application is the date a completed application is submitted to the city clerk's office and stamped by the same. The city clerk, upon review of the completed form, will place the application on the next regular city council agenda, even if such submission is a late file. Upon following the procedures of the council, as deemed appropriated in the sole judgment of the council, the application will be considered approved if the council votes favorably by majority. The application shall name one (1) person responsible on the application and shall provide contact information to include name, address, email address, and telephone number.

(2) *Exemptions.* Each event organizer or organization shall comply with this ordinance and no exemptions will be permitted.

(3) *Course map.* All applications shall be accompanied by a legible, precise course map showing the event route, water stops, refreshment stops, and so-called "port-a-potties". The course map shall also include any road closures, detours and parking areas. The course map shall be approved by police, fire, department of public services, parks commission and harbor masters departments prior to submission to the city clerk.

(4) *Electronic amplifier.* Electronic amplifiers, loudspeakers and bullhorn use shall be requested at time of application. Under no circumstances will they be used for public address announcements or music before 8:00 a.m., except for Sundays when electronic amplifiers, loud speakers or bullhorns will not be used for public address announcements or music before 9:00 a.m.

(5) *Road closure.* No ways, public or private, boat ramps or parking lots controlled or patrolled by the city shall be closed without authorization. Authorization shall be considered granted only if said closure(s) are contained in the approved permit. It is the sole responsibility of the race organizers to notify residents fourteen (14) days in advance that neighborhood roads will be closed if no alternate route is available to those residents. Notification shall be made by race organizers by informational packet drop-off at all residences that may be impacted, including, but not limited to, road closures, restricted driveway access, parking restrictions, or noise. In the case of multi-family residences with so-called security doors, notification will be sufficient at said security door. A copy of the notification shall be provided to the city clerk and, when possible, posted on the city website and distributed via email. Further,

a list of all streets notified shall be provided to the city clerk to be date stamped and appended to the application record. Press releases and other media type notifications are encouraged.

(6) *Insurance.* All events shall have an insurance policy or rider in effect for the event naming the "City of Newburyport" as an additional insured. The policy shall be no less than two million dollars (\$2,000,000.00).

(7) *Event termination.* If in the judgment of the city marshal, fire chief or department of public services (DPS) director or designees thereof determine that an event is unsafe due to existing conditions, that event may be stopped, terminated or suspended. In the case of a multidiscipline event such as a triathlon, the harbormaster or his/her designee may likewise stop, terminate or suspend the swimming portion for cause.

(8) *Event and traffic security.* The city marshal, fire chief, DPS director or in the case of a triathlon, the harbormaster can require special duty personnel to assist in the organizing and coordinating the safety and security of the event. All special duty assignments will be paid by the event organizers.

(9) *Clean-up.* The event organizers shall be responsible for post event trash collection, removal of signage, directional arrows, advertisements or other promotional material associated with the event.

10) *Parking.* The event organizers shall be responsible for including parking instructions in materials disseminated to event participants. If the event is happening within one-half mile of municipal parking, then participants shall be asked to park at such parking facilities.

(11) *Notification of previous event organizers.* To the extent reasonably possible, the city clerk shall notify all event organizers from events held from 2014—2016, inclusive, by a one-time phone, email, or letter of the new application timeline and other requirements.

(12) *Simplification.* Departments are encouraged to unify their respective applications into a singular application, managed and distributed by the city clerk's office.

(13) *Americans with Disabilities Act.* Event organizers are reminded of the importance of and expectation of adherence to the Americans with Disabilities Act of 1990 (42 U.S.C § 12101) and subsequent applicable amendments.

(e) *Enforcement.*

(1) *Regulations.* Consistent with this section, the city shall promulgate regulations to enforce and otherwise implement the provisions of this section upon passage by the city council. Any event previously approved by city council shall be deemed permitted.

(2) *Warning.* In the circumstance that this section is violated, the enforcement may consist of a warning. Any warnings issued for violation(s) will be reported to the city clerk and city council and may be used as a factor in future application approvals and denials.

(3) *Noncriminal disposition.* If the city determines that a violation has occurred in which a noncriminal violation is issued, the named event organizer shall be penalized by a non-criminal disposition as provided in Massachusetts General Law as adopted by the City of Newburyport as a general ordinance in section 1-17 of chapter 1 of the Code or Ordinances of the City of Newburyport in the amounts set herein in subsection (e)(4) below.

(4) *Violation.* The non-criminal violation shall be one hundred dollars (\$100.00) for the first offense and two hundred fifty dollars (\$250.00) for second and subsequent offenses. Any non-criminal citations issued for violation(s) will be reported to the city clerk and city council and shall be used as a factor in future application approvals and denials.

(5) *Failure to notify.* If the event fails to notify residents and provide documentation to the city clerk, pursuant to subsection (d)(5) above, shall render that organization ineligible to receive an event permit for a period of twelve (12) months unless special leave is granted by two-thirds supervote of the city council.

I fully understand and agree to all the terms set forth in this application. The information that I have provided is truthful and accurate. I accept all responsibility related to this event.

Signed: Kevin Sweeney

Date: 1/5/2024



CERTIFICATE OF LIABILITY INSURANCE

DATE (MM/DD/YYYY)

1/17/2024

THIS CERTIFICATE IS ISSUED AS A MATTER OF INFORMATION ONLY AND CONFERS NO RIGHTS UPON THE CERTIFICATE HOLDER. THIS CERTIFICATE DOES NOT AFFIRMATIVELY OR NEGATIVELY AMEND, EXTEND OR ALTER THE COVERAGE AFFORDED BY THE POLICIES BELOW. THIS CERTIFICATE OF INSURANCE DOES NOT CONSTITUTE A CONTRACT BETWEEN THE ISSUING INSURER(S), AUTHORIZED REPRESENTATIVE OR PRODUCER, AND THE CERTIFICATE HOLDER.

IMPORTANT: If the certificate holder is an ADDITIONAL INSURED, the policy(ies) must have ADDITIONAL INSURED provisions or be endorsed. If SUBROGATION IS WAIVED, subject to the terms and conditions of the policy, certain policies may require an endorsement. A statement on this certificate does not confer rights to the certificate holder in lieu of such endorsement(s).

PRODUCER Arthur J. Gallagher Risk Management Services, LLC 470 Atlantic Avenue Boston MA 02210	CONTACT NAME: PHONE (A/C No., Ext): 617-261-6700		FAX (A/C No.): 617-531-7777
	E-MAIL ADDRESS:		
		INSURER(S) AFFORDING COVERAGE	NAIC #
		INSURER A: Homeland Insurance Company of New York	34452
		INSURER B: Atlantic Specialty Insurance Company	27154
		INSURER C:	
		INSURER D:	
		INSURER E:	
		INSURER F:	

INSURED ALS Therapy Development Foundation Inc. 480 Arsenal Way Suite 201 Watertown MA 02472	ALSTHER-01
---	------------

COVERAGES

CERTIFICATE NUMBER: 1265648971

REVISION NUMBER:

THIS IS TO CERTIFY THAT THE POLICIES OF INSURANCE LISTED BELOW HAVE BEEN ISSUED TO THE INSURED NAMED ABOVE FOR THE POLICY PERIOD INDICATED. NOTWITHSTANDING ANY REQUIREMENT, TERM OR CONDITION OF ANY CONTRACT OR OTHER DOCUMENT WITH RESPECT TO WHICH THIS CERTIFICATE MAY BE ISSUED OR MAY PERTAIN, THE INSURANCE AFFORDED BY THE POLICIES DESCRIBED HEREIN IS SUBJECT TO ALL THE TERMS, EXCLUSIONS AND CONDITIONS OF SUCH POLICIES. LIMITS SHOWN MAY HAVE BEEN REDUCED BY PAID CLAIMS.

INSR LTR	TYPE OF INSURANCE	ADDL INSD	SUBR WVD	POLICY NUMBER	POLICY EFF (MM/DD/YYYY)	POLICY EXP (MM/DD/YYYY)	LIMITS	
B	<input checked="" type="checkbox"/> COMMERCIAL GENERAL LIABILITY <input type="checkbox"/> CLAIMS-MADE <input checked="" type="checkbox"/> OCCUR GEN'L AGGREGATE LIMIT APPLIES PER: <input checked="" type="checkbox"/> POLICY <input type="checkbox"/> PRO-JECT <input type="checkbox"/> LOC OTHER:	Y		GL05623-03	12/12/2023	12/12/2024	EACH OCCURRENCE	\$ 1,000,000
							DAMAGE TO RENTED PREMISES (Ea occurrence)	\$ 100,000
							MED EXP (Any one person)	\$ 10,000
							PERSONAL & ADV INJURY	\$ 1,000,000
							GENERAL AGGREGATE	\$ 2,000,000
							PRODUCTS - COMP/OP AGG	\$ 2,000,000
								\$
	AUTOMOBILE LIABILITY <input type="checkbox"/> ANY AUTO <input type="checkbox"/> OWNED AUTOS ONLY <input type="checkbox"/> SCHEDULED AUTOS <input type="checkbox"/> HIRED AUTOS ONLY <input type="checkbox"/> NON-OWNED AUTOS ONLY						COMBINED SINGLE LIMIT (Ea accident)	\$
							BODILY INJURY (Per person)	\$
							BODILY INJURY (Per accident)	\$
							PROPERTY DAMAGE (Per accident)	\$
								\$
A	<input type="checkbox"/> UMBRELLA LIAB <input checked="" type="checkbox"/> OCCUR <input checked="" type="checkbox"/> EXCESS LIAB <input type="checkbox"/> CLAIMS-MADE DED RETENTION \$	Y		EX04917-02	12/12/2023	12/12/2024	EACH OCCURRENCE	\$ 1,000,000
							AGGREGATE	\$ 1,000,000
								\$
	WORKERS COMPENSATION AND EMPLOYERS' LIABILITY ANY PROPRIETOR/PARTNER/EXECUTIVE OFFICER/MEMBER EXCLUDED? (Mandatory in NH) If yes, describe under DESCRIPTION OF OPERATIONS below	Y/N	N/A				PER STATUTE	OTHER
							E.L. EACH ACCIDENT	\$
							E.L. DISEASE - EA EMPLOYEE	\$
							E.L. DISEASE - POLICY LIMIT	\$

DESCRIPTION OF OPERATIONS / LOCATIONS / VEHICLES (ACORD 101, Additional Remarks Schedule, may be attached if more space is required)
 The City of Newburyport/ Certificate Holder is named additional insured.

CERTIFICATE HOLDER**CANCELLATION**

Town of Newburyport
 60 Pleasant Street
 Newburyport MA 01950

SHOULD ANY OF THE ABOVE DESCRIBED POLICIES BE CANCELLED BEFORE THE EXPIRATION DATE THEREOF, NOTICE WILL BE DELIVERED IN ACCORDANCE WITH THE POLICY PROVISIONS.

AUTHORIZED REPRESENTATIVE

© 1988-2015 ACORD CORPORATION. All rights reserved.



Town	Direction	Street Name	Police Detail	Notes	Cum. Miles
Durham, NH	Straight	Continue Straight on College Rd			0
Durham, NH	Right	Turn Right onto Main Street			0.3
Durham, NH	Straight	Continue onto Main Street			0.6
Durham, NH	Slight Right	Keep right onto NH 108			1
Durham, NH	Left	Turn left onto Durham Point Road			1.6
Durham, NH	Slight Right	Keep right onto Durham Point Road			3.6
Newmarket, NH	Left	Turn left onto North Main Street, NH 108			9.2
Newmarket, NH	Right	Keep right onto Main Street, NH 152			9.6
Newmarket, NH	Right	Turn right onto Packers Falls Road			9.8
Durham, NH	Continue Straight	Continue Straight on Packers Falls Road			10.7
Durham, NH	Left	Turn left onto Wiswall Road			12.2
Lee, NH	Continue Straight	Continue Straight on Wiswall Road			13.2
Lee, NH	Turn Left	Turn left onto Little Hook Road			13.5
Lee, NH	Turn Left	Turn left onto Lee Hook Road			14.5
Durham, NH	Continue Straight	Continue Straight onto Lee Hook Road			14.5
Newmarket, NH	Continue Straight	Continue Straight onto Lee Hook Road			15.2
Newmarket, NH	Turn Left	Turn Left onto Wadleigh Falls Rd			15.3
REST STOP 1		Folletts Brooke Parking Area - Wadleigh Falls Road, Newmarket, NH			15.7
Newmarket, NH	Turn Left	Turn left back onto Wadleigh Falls Rd			15.8
Newmarket, NH	Turn Right	Turn sharp right onto Grant Road			16.6
Newmarket, NH	Turn Left	Turn sharp left onto Ash Swamp Road			17.7
Newmarket, NH	Turn Right	Turn right onto Exeter Road, NH 108			19.9
Newfields, NH	Continue Straight	Continue Straight onto Exeter Road, NH 108			20.2
Newfields, NH	Turn right	Turn slight right onto Main Street, NH 85			20.7
Exeter, NH	Continue Straight	Continue Straight onto Main Street, NH 85			22.5
Exeter, NH	Left	Turn left onto Water Street, NH 27			25.6
Exeter, NH	Slight Left	Turn slight left onto High Street, NH 108, NH 111, NH 27			25.8
Exeter, NH	Straight	Continue onto High Street, NH 27, NH 111			25.9
Exeter, NH	Slight Right	Keep right onto Drinkwater Road			26.7
Exeter, NH	Slight Right	Turn slight right onto Drinkwater Road			26.7
Kensington. NH	Slight Left	Keep left onto Drinkwater Road			29
Kensington. NH	Straight	Continue onto Wild Pasture Road			29.8
Amesbury,MA	Straight	Straight onto Amesbury Road, NH 150			31.2
Amesbury,MA	Left	Turn left onto Fern Avenue			34.5
REST STOP 2		Cider Hill Farm- 45 Fern Ave, Amesbury, MA 01913			34.6
Amesbury,MA	Left	Turn Left out of Cider Hill Farm back onto Fern Ave			34.6
Amesbury,MA	Right	Keep right onto Fern Avenue			35.3
Amesbury,MA	Right	Turn slight right onto Congress Street			35.4
Amesbury,MA	Left	Turn left onto Elm Street			36.4
Amesbury,MA	Straight	Turn right onto Main Street			38.2

Amesbury,MA	Turn Left	Turn sharp left onto Merrimac Street			38.8
Amesbury,MA	Slight Left	Keep left onto Pleasant Valley Road			39.2
Merrimac,MA	Slight Right	Keep right onto Skunk Road			41.9
Merrimac,MA	Sharp Left	Turn sharp left onto Middle Road			42.2
Merrimac,MA	Straight	Continue onto River Road			42.6
Merrimac,MA	Bare Left	Keep Left on River Road			43.9
Haverhill, MA	Continue Straight	Continue onto River Road			44.3
West Newbury,MA	Left	Turn left onto East Main Street			43.7
West Newbury,MA	Turn Left	Turn left onto River Road			44.7
West Newbury,MA	Turn right	Keep right onto Coffin Street			46.9
West Newbury,MA	Left	Turn left onto Main Street, MA 113			47.8
Newburyport, MA	Continue Straight	Continue straight on Main Street/ Storey Avenue			49.9
Newburyport, MA	Turn Right	Turn right into Turkey Hill Road			50.3
Newburyport, MA	Bare Right	Bare Right to stay on Turkey Hill Road			51.2
West Newbury,MA	Continue Straight	Continue Straight on Turkey Hill Road			51.7
West Newbury,MA	Turn right	Turn right onto South Street			53.2
Newbury, MA	Turn Left	Turn Left onto Main Street			54
Georgetown, MA	Continue Straight	Continue Straight on Main Street			56
Georgetown, MA	Turn right	Turn right onto Thurlow Street			56.9
Groveland,MA	Continue Straight	Continue Straight on Byfield Rd			58.1
Groveland,MA	Continue Straight	Continue onto Seven Star Road			58.6
Groveland,MA	Turn Left	Turn left onto Bare Hill Road			58.6
Groveland, MA	Continue Straight	Continue Straight on Rollins St			59.7
Groveland, MA	Bear Left	Bear Left on Garrison St			60.4
Groveland,MA	Turn Right	Turn right onto King Street			60.8
Groveland,MA	Turn Right	Turn Right onto Main St, MA 113			61
REST STOP 3		Pines Recreation Area- 222 Main St, Groveland, MA 01834			61.4
Groveland,MA	Turn Right	Turn right onto Main Street, MA 113			61.4
Groveland,MA	Slight Right	Turn slight right onto Bates Bridge, MA 97, MA 113			61.8
Haverhill, MA	Right	Turn right onto Orchard Avenue			62.1
Haverhill, MA	Left	Turn left onto Old Ferry Road			62.1
Haverhill, MA	Right	Turn sharp right onto East Broadway			62.6
Haverhill, MA	Left	Keep left onto Millvale Road			63.8
Haverhill, MA	Continue Straight	Continue onto Millvale Road			64.2
Haverhill, MA	Turn Right	Turn slight right onto Middle Road			64.5
Haverhill, MA	Turn Right	Turn right onto Corliss Hill Road			66.4
Plaistow, NH	Turn Right	Turn slight right onto Newton Road, MA 108			67.5
Plaistow, NH	Straight	Continue Straight on South Main St, MA 108			68.3
Newton,NH	Straight	Continue Straight on South Main St, MA 108			68.3
Newton,NH	Straight	Straight onto Maple Avenue			71.7
South Hampton,NH	Straight	Continue Straight on Chase Rd			72.5

East Kingston, NH	Straight	Continue Straight on South Rd			74.1
REST STOP 4		East Kingston Elementary School-5 Andrews Ln, East Kingston, NH 03827			75.8
East Kingston, NH	Straight	Continue Straight on North St			75.8
East Kingston, NH	Left	Turn left onto Giles Road			77.8
East Kingston, NH	Slight Right	Keep right onto Joslin Road			78.5
Exeter, NH	Straight	Continue Straight on John West Rd			79
Exeter, NH	Slight Left	Turn slight left onto Kingston Road, NH 111			79.4
Exeter, NH	Right	Turn right onto Cross Road			79.7
Brentwood, NH	Left	Turn left onto Pickpocket Road			80.3
Brentwood, NH	Slight Left	Turn slight left onto Middle Road, NH 111A			82
Brentwood, NH	Right	Turn right onto Pine Road			82.1
Brentwood, NH	Left	Turn left onto Exeter Road, NH 27			83.6
Exeter, NH	Straight	Continue Straight on Exeter Road, NH 27			83.7
Epping, NH	Straight	Continue Straight on Exeter Road, NH 27			83.8
Epping, NH	Right	Turn right onto Mast Road			85.9
Newfields, NH	Straight	Continue Straight onto Mast Road			87.4
Newfields, NH	Right	Turn right onto Piscassic Road, NH 87			88
Newfields, NH	Left	Turn left onto Bald Hill Road			88.4
Newmarket, NH	Straight	Continue Straight on Bald Hill Road			89.2
Newmarket, NH	Left	Keep left onto Bald Hill Road			90.1
Newmarket, NH	Left	Turn slight left onto Grant Road			90.1
Newmarket, NH	Right	Turn right onto Camp Lee Road			90.3
Epping, NH	Continue Straight	Continue Straight onto Camp Lee Road			90.5
Lee, NH	Continue Straight	Continue Straight onto Camp Ground Road			91.3
Lee, NH	Left	Turn left onto Wadleigh Falls Road, NH 152			92.5
Lee, NH	Right	Turn sharp right onto Tuttle Road			92.5
Lee, NH	Right	Turn right onto North River Road, NH 155			94.3
REST STOP 5		Little River Park- 39 North River Rd, Lee, NH 03861			94.5
Lee, NH	Left	Keep right onto Mast Road, NH 155			94.5
Lee, NH	Straight	Keep right onto Wednesday Hill Road			94.9
Durham, NH	Straight	Continue Straight on Wednesday Hill Road			97
Durham, NH	Left	Keep left onto Packers Falls Road			97.6
Durham, NH	Left	Turn left onto Packers Falls Road			97.6
Durham, NH	Right	Turn sharp right onto Mill Road			98.3
Durham, NH	Left	Turn left onto McDaniel Drive			100.3



The High School
241 High Street
Newburyport, Massachusetts 01950

Lauren Gee
Director of Guidance

Jeanna Guardino
Special Ed Team Coordinator

Kyle Hodsdon
Director of Athletics

Michael Testa
Associate Principal

Andrew Wulf
Principal

April 29, 2024

Dear City Council,

On behalf of the Newburyport Public Schools Performing Arts Department we are requesting permission for Kona Ice to be present at the 5th Annual 2024 Newburyport Public Schools K-12 Performing Arts Waterfront Festival on Saturday, May 18, 2024 from 12-4 PM. This is the 5th annual event, generously sponsored by the Newburyport Education Foundation and the Institution for Savings. It would be our 7th, but sadly we were unable to perform for two years due to COVID.

All of the proper paperwork and requests went through The Waterfront Trust for this event, and with their permission and the continued assistance of City Hall and the DPW we are thrilled to be celebrating the performing arts in our schools!

At the request of students and their families, this year we thought it would be nice to have the Kona Ice truck come. Nikki Vazeos, the owner, and Newburyport resident is able to come to the Waterfront Park area from 1-4PM. Nikki graciously donates a portion of her profits to the organization where she is serving.

I have reached out to MaryJo Haley, the city's Parking Enforcement Supervisor, and she has the perfect (and safe) spot in mind for this--the dirt lot where the bathrooms used to be. Construction vehicles are staged there during the work week--but it is empty on the weekends. Mary Jo has offered to block it off for us. It directly abuts the park so there would not be a risk of kids running into the parking lot and being put in any dangerous situation.

We apologize for the late request. We are still learning all the ins and outs of proper protocol at the city level. We appreciate your support as we know this will bring an added layer of fun and spirit to anyone attending the festival!

Attached please find the insurance binder for Kona Ice (The Hadlan Group) listing City of Newburyport. Please let me know if any further information is needed.

Thank you,

Stephanie A. Phillips

K-12 Performing Arts Curriculum Coordinator

Newburyport Public Schools



CERTIFICATE OF LIABILITY INSURANCE

DATE (MM/DD/YYYY)
03/25/2024

THIS CERTIFICATE IS ISSUED AS A MATTER OF INFORMATION ONLY AND CONFERS NO RIGHTS UPON THE CERTIFICATE HOLDER. THIS CERTIFICATE DOES NOT AFFIRMATIVELY OR NEGATIVELY AMEND, EXTEND OR ALTER THE COVERAGE AFFORDED BY THE POLICIES BELOW. THIS CERTIFICATE OF INSURANCE DOES NOT CONSTITUTE A CONTRACT BETWEEN THE ISSUING INSURER(S), AUTHORIZED REPRESENTATIVE OR PRODUCER, AND THE CERTIFICATE HOLDER.

IMPORTANT: If the certificate holder is an ADDITIONAL INSURED, the policy(ies) must have ADDITIONAL INSURED provisions or be endorsed. If SUBROGATION IS WAIVED, subject to the terms and conditions of the policy, certain policies may require an endorsement. A statement on this certificate does not confer rights to the certificate holder in lieu of such endorsement(s).

PRODUCER Northern Kentucky Insurance 5915 Centennial Circle Florence, KY 41042		CONTACT NAME: Arnie Turner PHONE (A/C, No, Ext): (859)586-8580 E-MAIL ADDRESS: arnie@cornersoneinslc.com FAX (A/C, No): (859)586-8916	
INSURED The Hadjan Group 4 Jones Dr Newburyport, MA 01950		INSURER(S) AFFORDING COVERAGE INSURER A: Great American Alliance Company INSURER B: Great American Assurance Company INSURER C: INSURER D: INSURER E: INSURER F:	
		NAIC # 26832 26344	

COVERAGES CERTIFICATE NUMBER: 2024-2025 REVISION NUMBER:

THIS IS TO CERTIFY THAT THE POLICIES OF INSURANCE LISTED BELOW HAVE BEEN ISSUED TO THE INSURED NAMED ABOVE FOR THE POLICY PERIOD INDICATED. NOTWITHSTANDING ANY REQUIREMENT, TERM OR CONDITION OF ANY CONTRACT OR OTHER DOCUMENT WITH RESPECT TO WHICH THIS CERTIFICATE MAY BE ISSUED OR MAY PERTAIN, THE INSURANCE AFFORDED BY THE POLICIES DESCRIBED HEREIN IS SUBJECT TO ALL THE TERMS, EXCLUSIONS AND CONDITIONS OF SUCH POLICIES. LIMITS SHOWN MAY HAVE BEEN REDUCED BY PAID CLAIMS.

INSTR LTR	TYPE OF INSURANCE	ADDCSUBR INSD WVD	POLICY NUMBER	POLICY EFF (MM/DD/YYYY)	POLICY EXP (MM/DD/YYYY)	LIMITS
A	<input checked="" type="checkbox"/> COMMERCIAL GENERAL LIABILITY <input type="checkbox"/> CLAIMS-MADE <input checked="" type="checkbox"/> OCCUR GEN'L AGGREGATE LIMIT APPLIES PER: <input checked="" type="checkbox"/> POLICY <input type="checkbox"/> PRO-JECT <input type="checkbox"/> LOC OTHER:	Y	BOP3806114	04/25/2024	04/25/2025	EACH OCCURRENCE \$ 2,000,000 DAMAGE TO RENTED PREMISES (Ea occurrence) \$ 500,000 MED EXP (Any one person) \$ 10,000 PERSONAL & ADV INJURY \$ 2,000,000 GENERAL AGGREGATE \$ 4,000,000 PRODUCTS - COMP/OP AGG \$ 4,000,000 Additional Insured \$ 2,000,000
B	<input checked="" type="checkbox"/> AUTOMOBILE LIABILITY <input checked="" type="checkbox"/> ANY AUTO <input type="checkbox"/> OWNED AUTOS ONLY <input type="checkbox"/> SCHEDULED AUTOS <input type="checkbox"/> NON-OWNED AUTOS ONLY <input type="checkbox"/> HIRED AUTOS ONLY		CAP3806115	04/25/2024	04/25/2025	COMBINED SINGLE LIMIT (Ea accident) \$ 1,000,000 BODILY INJURY (Per person) \$ BODILY INJURY (Per accident) \$ PROPERTY DAMAGE (Per accident) \$ Uninsured motorist BI- \$ 1,000,000 EACH OCCURRENCE \$ AGGREGATE \$
	<input type="checkbox"/> UMBRELLA LIAB <input type="checkbox"/> OCCUR <input type="checkbox"/> EXCESS LIAB <input type="checkbox"/> CLAIMS-MADE <input type="checkbox"/> DED <input type="checkbox"/> RETENTION \$					PER STATUTE <input type="checkbox"/> OTH-ER <input type="checkbox"/> E.L. EACH ACCIDENT \$ E.L. DISEASE - EA EMPLOYEE \$ E.L. DISEASE - POLICY LIMIT \$
	<input type="checkbox"/> WORKERS COMPENSATION AND EMPLOYERS' LIABILITY <input type="checkbox"/> ANY PROPRIETOR/PARTNER/EXECUTIVE OFFICER/MEMBER EXCLUDED? (Mandatory in NJ) If yes, describe under DESCRIPTION OF OPERATIONS below	Y/N N/A				

DESCRIPTION OF OPERATIONS / LOCATIONS / VEHICLES (ACORD 101, Additional Remarks Schedule, may be attached if more space is required)
Certificate holder is listed as an additional insured with regards to the operations of the named insured.

CERTIFICATE HOLDER The City of Newburyport 60 Pleasant St. Newburyport, MA 01950	CANCELLATION SHOULD ANY OF THE ABOVE DESCRIBED POLICIES BE CANCELLED BEFORE THE EXPIRATION DATE THEREOF, NOTICE WILL BE DELIVERED IN ACCORDANCE WITH THE POLICY PROVISIONS. AUTHORIZED REPRESENTATIVE 
--	--

© 1988-2015 ACORD CORPORATION. All rights reserved.

RECEIVED
CIVIL ENGINEER'S OFFICE
NEWBURYPORT, MA

NEWBURYPORT SPECIAL EVENT APPLICATION

Tel. _____ Fax. _____

2024 MAY -8 P 1:10

(For Street Closure or Any Use of a Public Way - Please complete page 3 of this application)

NAME OF EVENT: Newburyport Public Schools K-12 Performing Arts Waterfront Festival (5th annual)

Date: May 18, 2024 Time: from 12 PM to 4 PM

Rain Date: May 19, 2024 Time: from 12 PM to 4 PM

2. Location*: Waterfront Park (approval already received from WFT)

*Please Note: If the location is a public park or the rail trail, please also contact the Parks Department

3. Description of Property: _____ Public _____ Private _____

4. Name of Organizer: Stephanie Phillips City Sponsored Event: Yes No _____

Contact Person

Address: 241 High Street Telephone: 603 978-465-4440

E-Mail: sphillips@newburyport.k12.ma.us Cell Phone: 603-918-6977

Day of Event Contact & Phone: same as above

5. Number of Attendees Expected: an ebb and flow of approx. 800

6. MA Tax Number: _____

7. Is the Event Being Advertised? yes Where? Newburyport Public Schools

8. What Age Group is the Event Targeted to? K-12 student performers, all ages audience

9. Have You Notified Neighborhood Groups or Abutters? Yes No _____, Who? Firehouse

ACTIVITIES: (Please check where applicable.) Subject to Licenses & Permits from Relevant City Departments

A. Vending*: Food Beverages _____ Alcohol _____ Goods _____ Total # of Vendors 1
(Kona Ice)
*If checked, signature from Health Director required (Page 3)

B. Entertainment: (Subject to City's Noise Ordinance.) Live Music DJ _____ Radio/CD _____
Performers Dancing Amplified Sound Stage

C. Games /Rides: Adult Rides _____ Kiddie Rides _____ Games _____ Raffle _____
Other _____ Total # _____

Name of Carnival Operator: _____

Address: _____

Telephone: _____

D. Organizer is responsible for clean-up during and after event. All trash must be collected and removed from event location immediately at the end of the event unless prior written agreement had been made with the Department of Public Services (DPS).

Will you be conducting the clean-up for this event? Yes No _____

If yes:

- a) How many trash receptacles will you be providing? we bring trash bags and clean up each year
- b) How many recycling receptacles will you be providing? we recycle what's appropriate
- c) Will you be contracting for disposal of : **Trash** Yes ___ No **Recycling** Yes ___ No
- i. If yes, size of dumpster(s): **Trash** _____ **Recycling** _____
- ii. Name of disposal company: **Trash** _____ **Recycling** _____
- iii. If no, will you remove trash & recycling with organizers' cars or trucks? Yes No ___
- iv. If no, where will the trash & recycling be disposed ? _____

If no:

- a) # of trash container(s) to be provided by DPS _____
- b) # of recycling container(s) to be provided by Recycling Office _____
- c) \$45.00/hr/DPS employee charge must be paid by the organizer to DPS in advance of the event (Fee for Special Events). The hours required for the event will be determined by DPS.

All fees must be paid prior to the event. Check or money order is payable to the City

of Newburyport. E. Portable Toilets: (Each cluster of portable toilets must include at least

one ADA accessible toilet)

_____ Standard # _____ ADA accessible

Name of company providing the portable toilets: _____

Sec. 13-97. - Road races, walkathons, bicycle and other multidisciplined events.

(a) *Short title.* This section may be cited as the "road races, walkathons and bicycle events."

(b) *Purpose and intent.* The use of city streets and sidewalks for the purpose of road races, walkathons or bicycle tours are positive events that promote exercise, general good health and Newburyport as a destination. These events do from time to time create hardships, impacting neighborhoods and traffic. To create a balance between conflicting interests, by safeguarding participants, residents, visitors and the City of Newburyport, this section will define and codify the procedure for the benefit of all.

(c) *Definitions.*

(1) *Road race.* A competitive or non-competitive running event that utilizes the streets, sidewalks and/or crosses over streets or sidewalks within city limits and in which an entry fee is required or charitable donation is solicited or suggested.

(2) *Walkathon.* A competitive or non-competitive walk event that utilizes the streets, sidewalks and/or crosses over streets or sidewalks within city limits and in which an entry fee is required or charitable donation is solicited or suggested.

(3) *Bicycle race.* A competitive or non-competitive bicycling event that utilizes the streets, sidewalks and/or crosses over streets or sidewalks within city limits and in which an entry fee is required or charitable donation is solicited or suggested.

(4) *Multidisciplined event.* A competitive or non-competitive event requiring or offering running, walking, biking, swimming or any combination thereof in which an entry fee is required or a charitable donation is solicited or suggested.

(5) *Event.* Any road race, walkathon, bicycle race, multi-disciplined event as defined above.

(d) *Limitations.*

(1) *Procedure.* All events shall, through that event's organizer, board of directors, charity foundation or designee ("organizer") apply for city council authorization to hold the event through the office of the city clerk no later than sixty (60) days before the event's proposed date. There shall be a grace period through December 31, 2017, during which applications will be accepted beyond the prescribed due date. Prior to application with the city council, the event shall file and receive approval from all applicable city departments, boards, and commissions. Copies of such approved applications, including along with documentation of any fees, donations, in-kind donations paid as part of said application(s), shall be included as part of the city council application.

The date of application is the date a completed application is submitted to the city clerk's office and stamped by the same. The city clerk, upon review of the completed form, will place the application on the next regular city council agenda, even if such submission is a late file. Upon following the procedures of the council, as deemed appropriated in the sole judgment of the council, the application will be considered approved if the council votes favorably by majority. The application shall name one (1) person responsible on the application and shall provide contact information to include name, address, email address, and telephone number.

(2) *Exemptions.* Each event organizer or organization shall comply with this ordinance and no exemptions will be permitted.

(3) *Course map.* All applications shall be accompanied by a legible, precise course map showing the event route, water stops, refreshment stops, and so-called "port-a-potties". The course map shall also include any road closures, detours and parking areas. The course map shall be approved by police, fire, department of public services, parks commission and harbor masters departments prior to submission to the city clerk.

(4) *Electronic amplifier.* Electronic amplifiers, loudspeakers and bullhorn use shall be requested at time of application. Under no circumstances will they be used for public address announcements or music before 8:00 a.m., except for Sundays when electronic amplifiers, loud speakers or bullhorns will not be used for public address announcements or music before 9:00 a.m.

(5) *Road closure.* No ways, public or private, boat ramps or parking lots controlled or patrolled by the city shall be closed without authorization. Authorization shall be considered granted only if said closure(s) are contained in the approved permit. It is the sole responsibility of the race organizers to notify residents fourteen (14) days in advance that neighborhood roads will be closed if no alternate route is available to those residents. Notification shall be made by race organizers by informational packet drop-off at all residences that may be impacted, including, but not limited to, road closures, restricted driveway access, parking restrictions, or noise. In the case of multi-family residences with so-called security doors, notification will be sufficient at said security door. A copy of the notification shall be provided to the city clerk and, when possible, posted on the city website and distributed via email. Further,

a list of all streets notified shall be provided to the city clerk to be date stamped and appended to the application record. Press releases and other media type notifications are encouraged.

(6) *Insurance.* All events shall have an insurance policy or rider in effect for the event naming the "City of Newburyport" as an additional insured. The policy shall be no less than two million dollars (\$2,000,000.00).

(7) *Event termination.* If in the judgment of the city marshal, fire chief or department of public services (DPS) director or designees thereof determine that an event is unsafe due to existing conditions, that event may be stopped, terminated or suspended. In the case of a multidiscipline event such as a triathlon, the harbormaster or his/her designee may likewise stop, terminate or suspend the swimming portion for cause.

(8) *Event and traffic security.* The city marshal, fire chief, DPS director or in the case of a triathlon, the harbormaster can require special duty personnel to assist in the organizing and coordinating the safety and security of the event. All special duty assignments will be paid by the event organizers.

(9) *Clean-up.* The event organizers shall be responsible for post event trash collection, removal of signage, directional arrows, advertisements or other promotional material associated with the event.

(10) *Parking.* The event organizers shall be responsible for including parking instructions in materials disseminated to event participants. If the event is happening within one-half mile of municipal parking, then participants shall be asked to park at such parking facilities.

(11) *Notification of previous event organizers.* To the extent reasonably possible, the city clerk shall notify all event organizers from events held from 2014—2016, inclusive, by a one-time phone, email, or letter of the new application timeline and other requirements.

(12) *Simplification.* Departments are encouraged to unify their respective applications into a singular application, managed and distributed by the city clerk's office.

(13) *Americans with Disabilities Act.* Event organizers are reminded of the importance of and expectation of adherence to the Americans with Disabilities Act of 1990 (42 U.S.C § 12101) and subsequent applicable amendments.

(e) *Enforcement.*

(1) *Regulations.* Consistent with this section, the city shall promulgate regulations to enforce and otherwise implement the provisions of this section upon passage by the city council. Any event previously approved by city council shall be deemed permitted.

(2) *Warning.* In the circumstance that this section is violated, the enforcement may consist of a warning. Any warnings issued for violation(s) will be reported to the city clerk and city council and may be used as a factor in future application approvals and denials.

(3) *Noncriminal disposition.* If the city determines that a violation has occurred in which a noncriminal violation is issued, the named event organizer shall be penalized by a non-criminal disposition as provided in Massachusetts General Law as adopted by the City of Newburyport as a general ordinance in section 1-17 of chapter 1 of the Code or Ordinances of the City of Newburyport in the amounts set herein in subsection (e)(4) below.

(4) *Violation.* The non-criminal violation shall be one hundred dollars (\$100.00) for the first offense and two hundred fifty dollars (\$250.00) for second and subsequent offenses. Any non-criminal citations issued for violation(s) will be reported to the city clerk and city council and shall be used as a factor in future application approvals and denials.

(5) *Failure to notify.* If the event fails to notify residents and provide documentation to the city clerk, pursuant to subsection (d)(5) above, shall render that organization ineligible to receive an event permit for a period of twelve (12) months unless special leave is granted by two-thirds supervote of the city council.

I fully understand and agree to all the terms set forth in this application. The information that I have provided is truthful and accurate. I accept all responsibility related to this event.

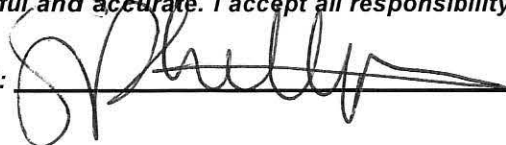
Signed: 

Date: 5/7/24

DEPARTMENT APPROVAL (for Committee Member use only):

It will be necessary for you to obtain permits or certificates from the following Departments: Please note that costs for some City support services during an event are an estimate only. Some Departments may forward an invoice for services rendered at the completion of the event, and others may require advance payment.

Approval Required	Date: _____	Signature _____
<input type="checkbox"/>	1. Special Events:	_____
<input checked="" type="checkbox"/>	2. Police:	<u>RLR</u>
	Is Police Detail Required:	<u>NO</u> # of Details Assigned: <u>0</u>
<input checked="" type="checkbox"/>	3. Traffic, Parking & Transportation:	<u>[Signature]</u>
<input checked="" type="checkbox"/>	4. ISD /Health:	<u>[Signature]</u>
<input type="checkbox"/>	5. Recycling:	_____
<input type="checkbox"/>	6. ISD /Building:	<u>[Signature]</u>
<input type="checkbox"/>	7. Electrical:	<u>[Signature]</u>
<input checked="" type="checkbox"/>	8. Fire:	<u>[Signature] Lt. Comora</u>
	Is Fire Detail Required:	<u>NO</u> # of Details Assigned: <u>0</u>
<input checked="" type="checkbox"/>	9. Public Works: Fee for Special Events: \$45/hr/DPS employee for trash handling/staging etc. may apply	
	Yes: \$ _____ due on _____	No Fee for Special Events applies
	Other requirements/instructions per DPS	<u>Wayne Amarat</u>
<input type="checkbox"/>	10. Parks Department:	<u>not needed - event application through WPT</u>
<input checked="" type="checkbox"/>	11. License Commission	_____

[Signature]
The departments listed above have their own application process. Applicants are responsible for applying for and obtaining all required permits & certificates from the various individual departments



CERTIFICATE OF LIABILITY INSURANCE

DATE (MM/DD/YYYY)
03/25/2024

THIS CERTIFICATE IS ISSUED AS A MATTER OF INFORMATION ONLY AND CONFERS NO RIGHTS UPON THE CERTIFICATE HOLDER. THIS CERTIFICATE DOES NOT AFFIRMATIVELY OR NEGATIVELY AMEND, EXTEND OR ALTER THE COVERAGE AFFORDED BY THE POLICIES BELOW. THIS CERTIFICATE OF INSURANCE DOES NOT CONSTITUTE A CONTRACT BETWEEN THE ISSUING INSURER(S), AUTHORIZED REPRESENTATIVE OR PRODUCER, AND THE CERTIFICATE HOLDER.

IMPORTANT: If the certificate holder is an ADDITIONAL INSURED, the policy(ies) must have ADDITIONAL INSURED provisions or be endorsed. If SUBROGATION IS WAIVED, subject to the terms and conditions of the policy, certain policies may require an endorsement. A statement on this certificate does not confer rights to the certificate holder in lieu of such endorsement(s).

PRODUCER Northern Kentucky Insurance 5915 Centennial Circle Florence KY 41042		CONTACT NAME: Amie Turner PHONE (A/C, No, Ext): (859)586-8580 FAX (A/C, No): (859)586-8616 E-MAIL ADDRESS: amie@cornerstoneinsllc.com	
		INSURER(S) AFFORDING COVERAGE	
		INSURER A: Great American Alliance Company	NAIC # 26832
		INSURER B: Great American Assurance Company	26344
		INSURER C:	
		INSURER D:	
		INSURER E:	
		INSURER F:	

COVERAGES **CERTIFICATE NUMBER:** 2024-2025 **REVISION NUMBER:**

THIS IS TO CERTIFY THAT THE POLICIES OF INSURANCE LISTED BELOW HAVE BEEN ISSUED TO THE INSURED NAMED ABOVE FOR THE POLICY PERIOD INDICATED. NOTWITHSTANDING ANY REQUIREMENT, TERM OR CONDITION OF ANY CONTRACT OR OTHER DOCUMENT WITH RESPECT TO WHICH THIS CERTIFICATE MAY BE ISSUED OR MAY PERTAIN, THE INSURANCE AFFORDED BY THE POLICIES DESCRIBED HEREIN IS SUBJECT TO ALL THE TERMS, EXCLUSIONS AND CONDITIONS OF SUCH POLICIES. LIMITS SHOWN MAY HAVE BEEN REDUCED BY PAID CLAIMS.

INSR LTR	TYPE OF INSURANCE	ADDL INSD	SUBR WVD	POLICY NUMBER	POLICY EFF (MM/DD/YYYY)	POLICY EXP (MM/DD/YYYY)	LIMITS	
A	<input checked="" type="checkbox"/> COMMERCIAL GENERAL LIABILITY <input type="checkbox"/> CLAIMS-MADE <input checked="" type="checkbox"/> OCCUR	Y		BOP3806114	04/25/2024	04/25/2025	EACH OCCURRENCE	\$ 2,000,000
	DAMAGE TO RENTED PREMISES (Ea occurrence)						\$ 500,000	
	MED EXP (Any one person)						\$ 10,000	
	PERSONAL & ADV INJURY						\$ 2,000,000	
GEN'L AGGREGATE LIMIT APPLIES PER: <input checked="" type="checkbox"/> POLICY <input type="checkbox"/> PROJECT <input type="checkbox"/> LOC OTHER:								
B	<input checked="" type="checkbox"/> AUTOMOBILE LIABILITY <input checked="" type="checkbox"/> ANY AUTO <input type="checkbox"/> OWNED AUTOS ONLY <input type="checkbox"/> HIRED AUTOS ONLY <input type="checkbox"/> SCHEDULED AUTOS <input type="checkbox"/> NON-OWNED AUTOS ONLY			CAP3806115	04/25/2024	04/25/2025	COMBINED SINGLE LIMIT (Ea accident)	\$ 1,000,000
	BODILY INJURY (Per person)						\$	
	BODILY INJURY (Per accident)						\$	
	PROPERTY DAMAGE (Per accident)						\$	
UMBRELLA LIAB <input type="checkbox"/> OCCUR EXCESS LIAB <input type="checkbox"/> CLAIMS-MADE DED RETENTION \$								
WORKERS COMPENSATION AND EMPLOYERS' LIABILITY ANY PROPRIETOR/PARTNER/EXECUTIVE OFFICER/MEMBER EXCLUDED? (Mandatory in NH) If yes, describe under DESCRIPTION OF OPERATIONS below		Y/N	N/A					
						PER STATUTE	OTH-ER	
						E.L. EACH ACCIDENT	\$	
						E.L. DISEASE - EA EMPLOYEE	\$	
						E.L. DISEASE - POLICY LIMIT	\$	

DESCRIPTION OF OPERATIONS / LOCATIONS / VEHICLES (ACORD 101, Additional Remarks Schedule, may be attached if more space is required)

Certificate holder is listed as an additional insured with regards to the operations of the named insured.

CERTIFICATE HOLDER

CANCELLATION

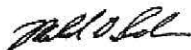
The City of Newburyport 60 Pleasant St, Newburyport MA 01950	SHOULD ANY OF THE ABOVE DESCRIBED POLICIES BE CANCELLED BEFORE THE EXPIRATION DATE THEREOF, NOTICE WILL BE DELIVERED IN ACCORDANCE WITH THE POLICY PROVISIONS.
	AUTHORIZED REPRESENTATIVE 

© 1988-2015 ACORD CORPORATION. All rights reserved.

ADDITIONAL COVERAGES

Ref #	Description ECOMM	Coverage Code ECOMM	Form No.	Edition Date	
Limit 1 50,000	Limit 2	Limit 3	Deductible Amount	Deductible Type	Premium
Ref #	Description FINCG	Coverage Code FINCG	Form No.	Edition Date	
Limit 1	Limit 2	Limit 3	Deductible Amount	Deductible Type	Premium
Ref #	Description Designated Person	Coverage Code DESIG	Form No.	Edition Date	
Limit 1	Limit 2	Limit 3	Deductible Amount	Deductible Type	Premium \$25.00
Ref #	Description Medical payments	Coverage Code MEDPM	Form No.	Edition Date	
Limit 1 5,000	Limit 2	Limit 3	Deductible Amount	Deductible Type	Premium
Ref #	Description PIP-Basic	Coverage Code PIP	Form No.	Edition Date	
Limit 1	Limit 2	Limit 3	Deductible Amount	Deductible Type	Premium
Ref #	Description	Coverage Code	Form No.	Edition Date	
Limit 1	Limit 2	Limit 3	Deductible Amount	Deductible Type	Premium
Ref #	Description	Coverage Code	Form No.	Edition Date	
Limit 1	Limit 2	Limit 3	Deductible Amount	Deductible Type	Premium
Ref #	Description	Coverage Code	Form No.	Edition Date	
Limit 1	Limit 2	Limit 3	Deductible Amount	Deductible Type	Premium
Ref #	Description	Coverage Code	Form No.	Edition Date	
Limit 1	Limit 2	Limit 3	Deductible Amount	Deductible Type	Premium
Ref #	Description	Coverage Code	Form No.	Edition Date	
Limit 1	Limit 2	Limit 3	Deductible Amount	Deductible Type	Premium

Committee Items – May 13, 2024

Public Works & Safety

In Committee:

- APPT00484_04_08_2024 Thomas Baillie 35 Marlboro St. Water Sewer Comm. Alt. 4/30/2026
- Re-appointment:*
- APPT00487_04_29_2024 Adam Armstrong 5 Buck St. Harbor Commission 6/1/2027
 - ODNC00171_04_29_2024 Amend Ch.13 to move the HP on Pleasant St.
 - COMM00527_01_08_2024 Letter from Philip Cootey



CITY OF NEWBURYPORT
OFFICE OF THE MAYOR
SEAN R. REARDON, MAYOR

60 PLEASANT STREET - P.O. BOX 550
NEWBURYPORT, MA 01950
978-465-4413 PHONE
MAYOR@CITYOFNEWBURYPORT.COM

RECEIVED
CITY CLERK'S OFFICE
NEWBURYPORT, MA
2024 APR - 2 P 12: 56

To: President and Members of the City Council
From: Sean R. Reardon, Mayor
Date: April 8, 2024
Subject: Appointment

I hereby appoint, subject to your approval, the following named individual as an alternate member of the Water/Sewer Commission. This term will expire April 30, 2026.

Thomas C. Baillie
35 Marlboro Street
Newburyport, MA 01950

A handwritten signature in cursive script, appearing to read "S R Reardon".

35 Marlboro Street
Newburyport, MA 01950

February 17, 2024

Attn: Christine Jackson
Executive Assistant, Mayor's Office
60 Pleasant Street
Newburyport, MA 1950

I am interested in serving on the Board of Water/Sewer Commissioners. If you are interested in augmenting your board with a seasoned construction executive who worked through the challenges of managing and growing a heavy civil construction enterprise, please consider my application.

I am retired and have lived in Newburyport since 2019. I have been thinking about doing something to serve the city and this would be a great way. I have had many years of working in water and sewer construction and I have some municipal experience where I served on the Community Planning and Development Commission when I lived in Reading, MA.

I did read through some of the meeting minutes and agendas on the website and I think I could be effective participant on the board. It would be a great way for me to learn about the city operations and government.

I have attached some additional information about myself. Please let me know if you have any questions and thank you for your consideration.

Sincerely,



THOMAS C. BAILLIE
617-839-0972
tcbailie@gmail.com

THOMAS C BAILLIE

35 Marlboro Street | Newburyport, MA 01950 | 617-839-0972 | tcbaille@gmail.com

EXPERIENCE

President Emeritus

Bond Civil & Utility, Inc. Medford, MA 1994-2019

Project management and estimating for gas and electrical transmission projects, power plant construction, district energy systems, university campus hardscape and athletic fields and airport and transit system public infrastructure.

Heavy Equipment Operator

Massachusetts Army National Guard 181st Engineers Camp Edwards, MA 1980-1986

EDUCATION

M.S. Civil Engineering

University of Massachusetts Lowell Lowell, MA 1989

B.S. Civil Engineering

University of Massachusetts Amherst Amherst, MA 1983

Board Governance Certificate

University of Pennsylvania Philadelphia, PA 2023

LICENSES

Registered Professional Engineer Commonwealth of Massachusetts

Registered Land Surveyor Commonwealth of Massachusetts

RELEVANT PROJECTS

Logan Airport Modernization Terminal A Site, Concrete and Fuel Line

Eversource 345kV Underground Transmission Stoughton to Boston

Eversource 345 kV Underground Norwalk to Middletown, CT

Iberdrola Wind Farm Project

Enbridge West Roxbury Lateral Gas Transmission Line

Iberdrola Salem Harbor Energy Center

Harvard University Northwest Yard Utility Upgrade

MIT Nano Utility Enabling Project

BOARD BIOGRAPHY THOMAS C BAILLIE



Thomas C. Baillie is President Emeritus of Bond Civil & Utility Construction, Inc. He was employed at Bond from 1994 to 2019 and worked in the construction business for 40 years. Mr. Baillie's leadership guided the firm through many highly challenging civil infrastructure and utility projects. He directed the growth of Bond Civil & Utility from a small city utility contractor with revenues of \$10 million per year to a large regional contractor working throughout the northeast U.S. with revenues of \$200 million per year. This was accomplished by implementing a strategic plan that included corporate reorganization, talent recruitment, employee retention, focused business development and implementation of estimating, scheduling and project management software. Mr. Baillie began his career serving as a heavy equipment operator for the Massachusetts Army National Guard's 181st Engineers. He holds a B.S. degree in Civil Engineering from the University of Massachusetts Amherst where he was inducted as a Civil Engineering Distinguished Alumni in 2018. Further, he holds an M.S. degree from the University of Massachusetts Lowell where he also taught as an adjunct professor. Mr. Baillie served on the Civil Engineering Advisory Boards at both universities. He is also a licensed professional engineer and land surveyor in the Commonwealth of Massachusetts. Mr. Baillie currently serves on the Board of Directors for Sargent Corporation.



CITY OF NEWBURYPORT
OFFICE OF THE MAYOR
SEAN R. REARDON, MAYOR

60 PLEASANT STREET - P.O. BOX 550
NEWBURYPORT, MA 01950
978-465-4413 PHONE
MAYOR@CITYOFNEWBURYPORT.COM

To: President and Members of the City Council
From: Sean R. Reardon, Mayor
Date: April 29, 2024
Subject: Re-Appointment

RECEIVED
CITY CLERK'S OFFICE
NEWBURYPORT, MA
2024 APR 25 A 8:41

I hereby re-appoint, subject to your approval, the following named individual as a member of the Harbor Commission. This term will expire on June 1, 2027.

Adam Armstrong
5 Buck Street
Newburyport, MA 01950

Adam Armstrong
5 Buck Street
Newburyport, MA 01950

Mr. James Knapp
Newburyport Harbor Commissioner
27 Rear Water St,
Newburyport, MA 01950

Dear Commissioner Knapp,

I am writing this letter regarding my interest in re-appointment to the Newburyport Harbor Commission.

When I first joined the Commission, I had only a small background regarding the responsibilities of the Newburyport Harbor Commission. During my time I have enjoyed learning our city's maritime history and supporting the priorities of the Newburyport Harbor Master. Several the areas I have been involved in over the past seven years include:

- Approving new water sheets, which includes oversight to changes of marinas, private docks, and moorings.
- Providing recommendations to the city and other authorities regarding any new projects associated with the river. Examples include dredging, FNP changes, and CSOs.
- Composing and submitting new city ordinances to city council for approval. Examples include house boats, water way fees, and safety recommendations.
- Acting as Harbor Commission liaison to the 8 Towns and the Great Marsh committee

I have lived in Newburyport for close to 20 years and I am fully dedicated to keeping our waterways safe, clean, and open for the enjoyment of our residents.

Thank you for your consideration,

Adam Armstrong

ADAM P. ARMSTRONG, PMP

617.852.1864 ▪ 5 Buck Street ▪ Newburyport, MA 01950 ▪ aparmstrong@yahoo.com ▪ [LinkedIn](#)

PROFILE

- Information technology and financial services professional offering leadership, management, design thinking, and vision.
- Experienced in corporate Agile implementation and transformation initiatives.
- Proven ability to communicate effectively with clients, team members, and management.
- Experienced manager working with demanding clients in large scale systems implementations.
- Proficient in visualizing organizational direction and process improvement.
- Skilled at supervising professional, technical, and support staff.

PROFESSIONAL EXPERIENCE

LIBERTY MUTUAL, US Retail Markets

Portsmouth, NH 2011 – present

Director, Product Owner

- Lead and manage 8 Agile Product Owners supporting Liberty Mutual, Safeco and Business Lines Billing and Payment functionality.
- Managed program implementation of a shared general ledger system working with business and IT partners in 15 country operations across Europe, Asia, and South America.
- Responsible for hiring, training, and coaching multi-located product owners, scrum masters, analysts and developers working in Agile Scrum and Kanban methodologies.

OLMSTEAD ASSOCIATES, INC

Boston, MA 2004 - 2011

Senior Project Manager, Executive Board Member

Client Assignments for this global securities industry consulting firm include:

Bank of New York Mellon - Fixed Income & Cash Management, Boston MA (2008 – 2011)

Project Manager for a vendor product search and multi-currency accounting systems implementation.

Fidelity Investments – Personal Wealth Investment Technology, Boston MA (2006 – 2008) Systems

Project Manager for an online personal rate of return solution.

Western Asset Management Company, Pasadena CA (2005 – 2006)

Project Lead for historical data conversion project from Citigroup Asset Management.

Atlantic Trust Private Wealth Management, Boston MA (2005 – 2005)

Lead Analyst for corporate consolidation project.

Wells Fargo Advisors – Client Strategy Group, Richmond, VA (2004 - 2005)

Team Lead for the implementation and testing of a daily performance measurement system.

STATE STREET CORPORATION

Boston, MA 1998 - 2004

Senior Project Analyst – Business Project Services

- Managed project deliverables by developing strategy, resolving issues, and prioritizing actions.

THOMSON REUTERS

Boston, MA 1995 - 1998

Implementation Consultant

- Coordinated installation and conversion of new clients, on-site trials, and pre-sale demonstrations.

Performance Analyst

- Provided monthly production of portfolio and composite performance results for clients.

EDUCATION and PROFESSIONAL DEVELOPMENT

- **Bentley University**, Waltham, MA. Master of Science in Computer Information Systems.
- **Loyola University Maryland**, Baltimore, MD. Bachelor of Business Administration, Finance.
- **Merrimack College**, North Andover, MA. Project Management Certificate.

CERTIFICATIONS AND PROFESSIONAL AFFILIATIONS

- Ideo CoLab Corporate Fellowship
- Certified Project Management Professional (PMP)
- Certified Agile Leadership (CAL) Essentials, Team and Organization Certified
- Member, Mass Bay Chapter – Project Management Institute
- Member, National Eagle Scout Association
- City of Newburyport – Harbor Commission

CITY OF NEWBURYPORT



IN CITY COUNCIL

ORDERED:

April 29, 2024

AN AMENDMENT TO AN ORDINANCE TO ADD A NEW HANDICAPPED PARKING SPACE PURUSANT TO SECTION 179 OF CHAPTER 13 (TRAFFIC AND MOTOR VEHICLES) OF THE MUNICIPAL CODE

Be it ordained by the City Council of the City of Newburyport as follows:

Chapter 13	Traffic and Motor Vehicles
Article 4	Specific Street Schedules
Division 6	Stopping, Standing and Parking
Section 13-179	Handicapped Zones

Amend Section 13-179 by inserting a new line, as follows, with deletions ~~double-stricken through~~, and additions double-underlined:

No person, without a duly authorized handicapped vehicle registration or placard, as described in M.G.L.A. c. 90, § 2 shall park a vehicle in any of the following described parking spaces as designated by signs and symbols:

Pleasant Street:

~~In front of the general store.~~

Pleasant Street, North side, from a point 25' west of Inn Street to a point 45' west of Inn Street.

Councillor James J. McCauley

Councillor Jennie L. Donahue

In City Council April 29, 2024:

Motion to refer to Public Works & Safety by Councillor McCauley, seconded by Councillor Preston.

Roll call vote, 11 yes, motion passes.



Data Sources: Produced by Merrimack Valley Planning Commission (MVPC) using data provided by the City of Newburyport & MassGIS. MVPC AND THE CITY OF NEWBURYPORT MAKES NO WARRANTIES, EXPRESSED OR IMPLIED, CONCERNING THE ACCURACY, COMPLETENESS, RELIABILITY, OR SUITABILITY OF THESE DATA. THE CITY OF NEWBURYPORT AND MVPC DOES NOT ASSUME ANY LIABILITY ASSOCIATED WITH THE USE OR MISUSE OF THIS INFORMATION.

Municipal Boundary
 Roads
 Interstate
 Major Road
 Local Road
 Railroad
 Parcels

PLEASANT ST & INN ST - PROPOSED CROSSWALK
 RELOCATE TO SPACE 20' WEST OF EXISTING.



Phillips Dr. Neighborhood Committee

22 Phillips Drive
pcootey@hotmail.com
978 223 5303

06/01/2024

Dear Council President Cameron,

Greetings and Happy New Year to you and the council.

We appreciate the work that the city has done thus far for our neighborhood which has a long history of problems. Since 1999, homeowners of the Phillips Drive neighborhood have been issuing concerted complaints to the City about flooding, property damage, and other environmental and public safety hazards due to improper water drainage. Problems and complaints began to be filed over 30 years ago during Mayor Al Lavender's term. Work has finally begun, in 2023, over twenty years after our concerted advocacy for a solution began and we are so greatly appreciative of this focus on our neighborhood.

The project is taking longer than projected and we have become aware that more funding has been sought, for example, to supplement the budget for the neighborhood liaison. We are also aware of changes required to the plan after the original infrastructure was exposed, for example at the bridge in the lowest point of the neighborhood. *We are aware these requests are being met with resistance* and humbly request the council speak about their thoughts on this project.

We wish to advocate to the council for the completion of our project in a manner that addresses the problems we started with and not in a manner that simply brings the project to an end without fully addressing these problems.

We are looking forward to the update on the project which has been scheduled at the Sr. Center on January 17th, at 6PM. We cordially invite every councilor to come and hear about the project's progress, how the city is addressing the new timeline; as well as, to hear from the neighborhood.

Drainage issues continue to plague the neighborhood. We have had recent flooding, property damage and safety hazards due to the water volume in the streets this fall, winter, and now have freezing water on the street. We need the work to finish and to be done correctly to stay safe and dry in our own homes.

Regards/Sincerely/Best,

Philip Cootey

On behalf of: The Phillips Drive Neighborhood Committee