



City of Newburyport

Application Form Restaurant License Occupy Outdoor City Property

****DO NOT USE THIS APPLICATION FORM FOR EVENTS****

Date Submitted: 03/11/2022

Business Name: Battle Grounds Coffee Company

Business Contact: Dana DeFranco

Business Address: 33 Pleasant St Phone: 255-2693 Email: dan@battlecoffee.com

Property Owner: Dan Abdulla 978-417-9052 dpabdulla@aol.com

Outdoor Tables Quantity: 3 Dimensions: 29.5" W x 29" H Material: metal

Outdoor Chairs Quantity: 6 Dimensions: 20" W x 22" D x 31" H Material: metal + wicker

Proposed Days/Hours of Operation: 7am - 8pm (summer hours)

Check all that apply:

- Applicant requests approval for food consumption.
- Applicant requests approval for alcohol consumption.
- Applicant requests approval for occupancy of public parking space(s).

Attach the following materials:

- 1) Evidence of liability insurance with minimum coverage in the amount of one million dollars (\$1,000,000) per occurrence, naming the City of Newburyport as co-insured, and in force for the entire approved period of occupancy.
- 2) A clear and legible 8 1/2-inch x 11-inch diagram of the proposed area of occupancy, detailing:
 - a) Perimeter of proposed areas of occupancy, with relevant linear dimensions;
 - b) Public, pedestrian path of travel no less than five feet in width;
 - c) All relevant obstacles such as streetlights, signs, trees, etc.; and
 - d) All tables, chairs, seats, total seating count and total occupancy; and
 - e) Means to demarcate any areas proposed for the service of food and alcohol.
- 3) Written authorization signed by the Applicant's landlord acknowledging and agreeing to the use of the adjacent portion of any public way.

Applications shall be delivered to the Office of the City Clerk by hand, mail, or email:

- 1) Office of the City Clerk
Newburyport City Hall
60 Pleasant Street
Newburyport, MA 01950
(978) 465-4407 ext. 1205
rjones@cityofnewburyport.com
- 2) The deadline for applications is the close of business 7:00 pm Thursday, March 10th.

Processing:

- 1) Application fee \$100.00
Occupancy fee \$5/sq. ft. pending in City Council.
- 2) Applications will be reviewed by the City Council and forwarded to the Licensing Board. For applications to occupy a city park or playground, the City Council shall not consider or act upon such application until the earlier of (i) having received a recommendation by the Parks Commission regarding such application, or (ii) 30 days from the City Clerk's receipt of such complete application.
- 3) The **Licensing Board will then conduct a public hearing** on each application and determine whether to approve, approve conditionally, or deny it. The Licensing Board may not approve an application without a favorable recommendation by the City Council.
- 4) The City has no obligation whatsoever to approve any individual application, each of which shall be processed, reviewed, and a determination thereon made by the relevant City officers, boards, and commissions in their reasonable discretion.
- 5) Any condition of approval and submitted plan shall be in force for the entire duration of any validly issued license.
- 6) Any license issued may be revoked at any time by super-majority vote of the City Council, after a public hearing, for any reason, or no reason.

RELEASE AND INDEMNITY AGREEMENT TO ENCUMBER A PUBLIC WAY

I, the undersigned Applicant or Duly Authorized Agent, hereby agree to RELEASE, DISCHARGE, and HOLD HARMLESS, the City of Newburyport, a municipal corporation of the Commonwealth of Massachusetts, and its officers, employees, agents, and servants from all actions, causes of action, claims, demands, damages, costs, loss of services, expenses and compensation associated with the undersigned's use of the public way or other city property as described herein.



Signature of Business Owner

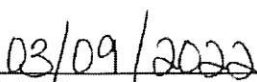

DATE

BATTLE GROUNDS COFFEE CO.

Store Front
33 Pleasant St

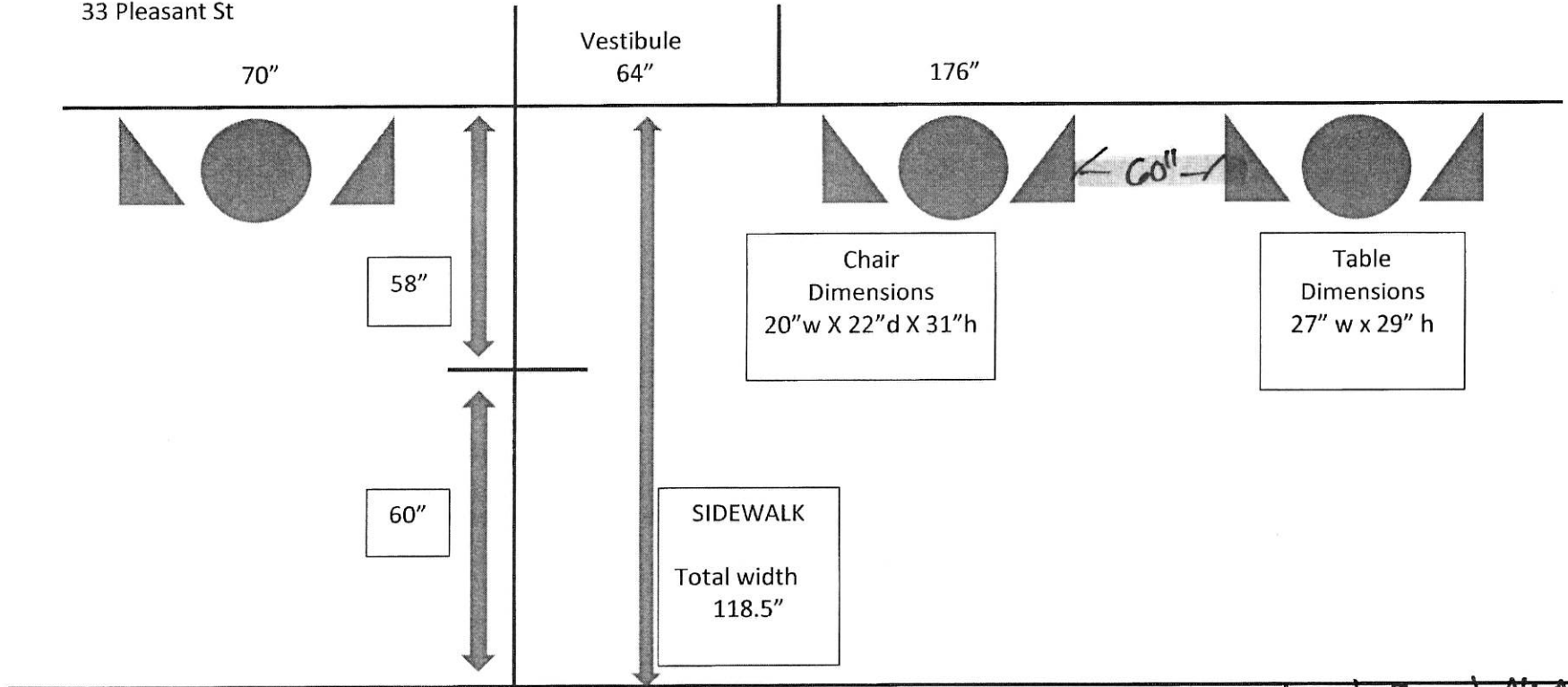

PLEASANT STREET



- 36" must be maintained Around All Areas
- 60" between tables for wheel chair turning
- Tables must be ADA

Heights - 27" - 34"
19" clear under table

(DPN)